

NOTES:

- 1) SWITCH DIFFERENTIAL IS APPROX. 1.25 [31.7] WHEN USED IN OIL WITH .97 DENSITY.
- 2) ALARM SWITCH OPERATES ON LOWERING OIL LEVEL. WHEN OIL LEVEL "X" IS REACHED, 11 CLOSES ON 14 & OPENS ON 12.
- 3) SWITCH DATA: SPDT SNAP SWITCH 4 AMPS @ 110/220 VAC.
- 4) MAX. OPERATING PRESSURE: 17.4 PSIG [1.2 BAR], MAX. OPERATING VACUUM: 15 in.Hg.
- 5) CABLE DIRECTION ADJUSTABLE (360°).
- 6) DIMENSIONS ARE SHOWN IN INCHES [MILLIMETERS].
- 7) UNIT IS DESIGNED TO OPERATE IN OIL UP TO 120°C.
- 8) UNIT IS DESIGNED FOR VERTICAL INSTALLATION AND MEETS THE REQUIREMENTS OF IP54.
- 9.) COVER AND HOUSING, DIE CAST ALUMINUM, CHROMATED AND PAINTED ANSI #70 LT. GRAY.

REVISION	PART NO.	OIL LEVEL "X" ±8 MM	(REF) FOR CALIBRATION ONLY: FLOAT PIN POSITION "X" ±5MM	LENGTH "L"
NOT ISSUED	<del>049-101-01</del>			
46027 1/31/25	049-101-02	191 MM	191 MM	239 MM
46027 1/31/25	049-101-03	156 MM	156 MM	204 MM

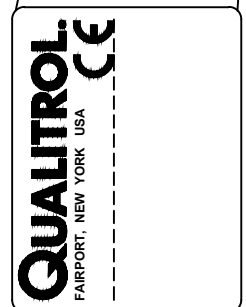
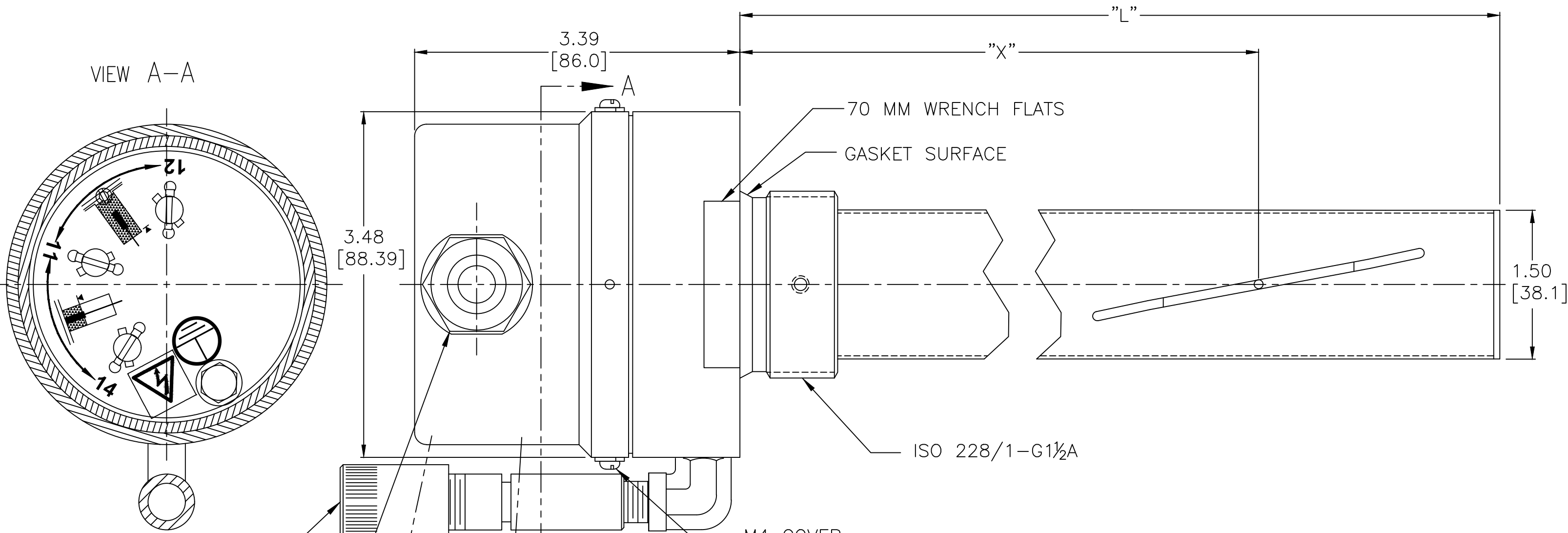

APPLIED TO COVER

**NOTICE**  
THIS DRAWING IS THE PROPERTY OF QualITROL COMPANY LLC AND IS LOANED ONLY ON THE CONDITION THAT IT WILL BE USED TO FACILITATE THE PURPOSE FOR WHICH IT WAS INTENDED AND NOT BE REPRODUCED, COPIED OR OTHERWISE DISPOSED OF, AND IS NOT TO BE USED IN WHOLE OR PART FOR FURNISHING INFORMATION RELATIVE TO THE MAKING OF DRAWINGS, PARTS, APPARATUS OR PARTS THEREOF, EXCEPT BY WRITTEN ORDER FROM QualITROL COMPANY LLC.

LET	DATE	ALTERATION	C.N.
-	1/31/25	DENSITY WAS .87, TEMP WAS 100C ADD GAP TO COV ASSY., 86MM WAS 84.84	46027
-	4-18-18	CORRECTED INSULATOR VIEW MARKINGS	37790
-	12-7-17	ADDED LABELS FOR CE COMPLIANCE	36995
-	6-27-16	ADDED NOTE 9, ON MATERIALS AND PAINT	35209

TOLERANCE UNLESS NOTED, [MM] IS FOR REF.:  
2 PLC. DECIMAL ± .02 [.5]  
3 PLC. DECIMAL ± .005 [.13]  
ANGULAR ± 2 DEG.

**QUALITROL**  
FORM 0-467 REV. E 04/06/06  
FAIRPORT, NEW YORK

DRAWN	DATE
HT	08-14-98
CHECK	DATE
JAV	08-14-98
APP'D	DATE
JAV	08-14-98

TITLE: VERTICAL OIL LEVEL SWITCH	
MATERIAL:	
FINISH:	
SCALE: 1:1	SHEET 1 OF 1 DRAWING NO. 049-101