

# AC axial fan

sickled blades (S series), single inlet  
with guard grille for short nozzle

## ebm-papst Mulfingen GmbH & Co. KG

Bachmühle 2 · D-74673 Mulfingen

Phone +49 7938 81-0

Fax +49 7938 81-110

info1@de.ebmpapst.com

www.ebmpapst.com

Limited partnership · Headquarters Mulfingen

County court Stuttgart · HRA 590344

General partner Elektrobau Mulfingen GmbH · Headquarters Mulfingen

County court Stuttgart · HRB 590142

## Nominal data

Type	S4D315-AS10-31		
Motor	M4D068-DF		
Phase		3~	3~
Nominal voltage	VAC	400	400
Connection		Y	Y
Frequency	Hz	50	60
Type of data definition		ml	ml
Valid for approval / standard		-	-
Speed (rpm)	min <sup>-1</sup>	1330	1460
Power input	W	100	135
Current draw	A	0.25	0.25
Max. back pressure	Pa	65	80
Min. ambient temperature	°C	-25	-25
Max. ambient temperature	°C	65	70
Starting current	A	0.63	0.62

ml = Max. load · me = Max. efficiency · fa = Running at free air · cs = Customer specs · cu = Customer unit  
Subject to alterations



# AC axial fan

sickled blades (S series), single inlet  
with guard grille for short nozzle

## Technical features

<b>Mass</b>	3.2 kg
<b>Size</b>	315 mm
<b>Surface of rotor</b>	Coated in black
<b>Material of blades</b>	Press-fitted sheet steel blank, sprayed with PP plastic
<b>Material of guard grille</b>	Steel, coated in black plastic (RAL9005)
<b>Number of blades</b>	5
<b>Direction of air flow</b>	"A"
<b>Direction of rotation</b>	Clockwise, seen on rotor
<b>Type of protection</b>	IP 44; Depending on installation and position as per EN 60034-5
<b>Insulation class</b>	"F"
<b>Humidity (F)/environmental protection class (H)</b>	H0+
<b>Max. permissible ambient motor temp. (transp./ storage)</b>	+ 80 °C
<b>Min. permissible ambient motor temp. (transp./storage)</b>	- 40 °C
<b>Mounting position</b>	Shaft horizontal or rotor on bottom; rotor on top on request
<b>Condensate discharge holes</b>	Rotor-side
<b>Operation mode</b>	S1
<b>Motor bearing</b>	Ball bearing
<b>Touch current acc. IEC 60990 (measuring network Fig. 4, TN system)</b>	< 0.75 mA
<b>Cable exit</b>	Axial
<b>Protection class</b>	I (if protective earth is connected by customer)
<b>Product conforming to standard</b>	EN 60335-1, motor does not have factory-installed overheating protection
<b>Approval</b>	EAC



# AC axial fan

sickled blades (S series), single inlet  
with guard grille for short nozzle

## Product drawing

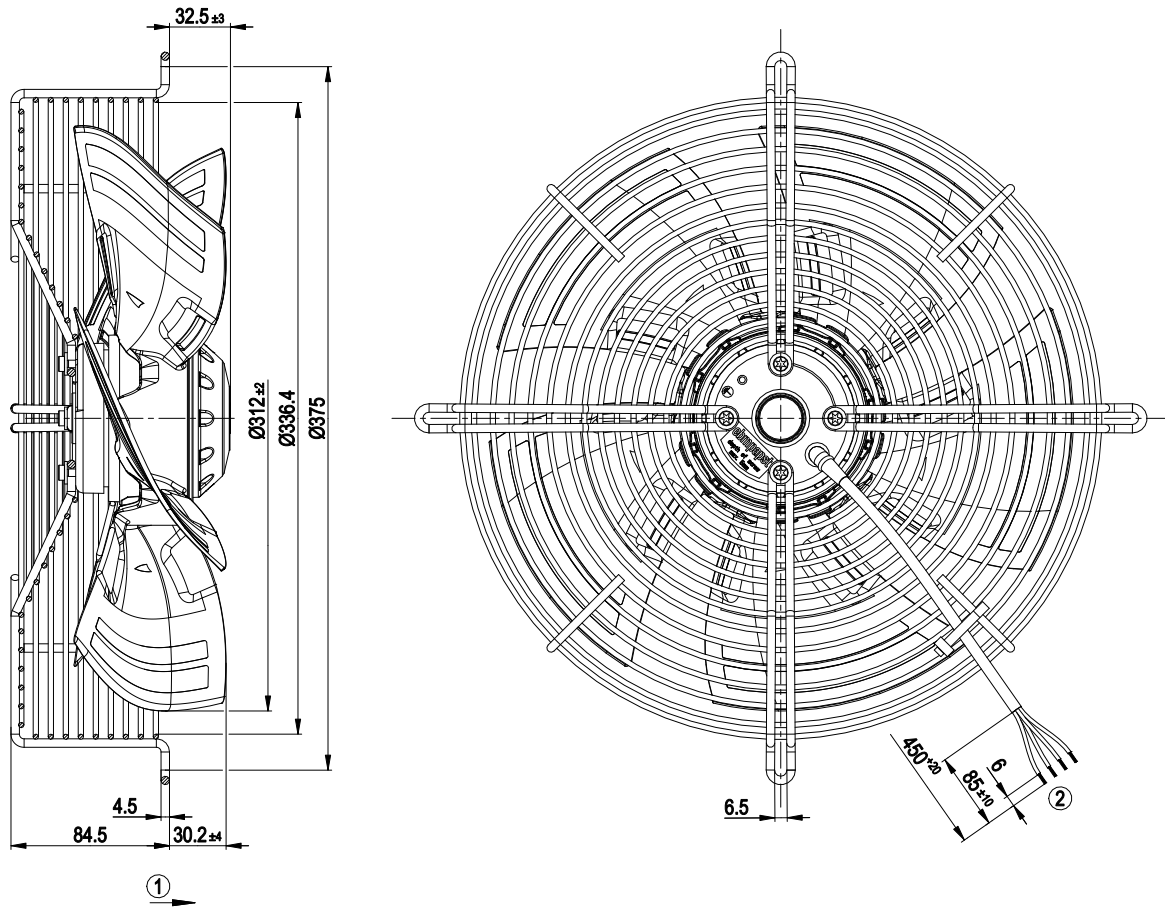

- |   |  |
|---|--|
| 1 | Direction of air flow "A"  |
| 2 | Connection line silicone 4G 0.5 mm <sup>2</sup> , 4x lead tips crimped |



# AC axial fan

sickled blades (S series), single inlet  
with guard grille for short nozzle

## Connection screen

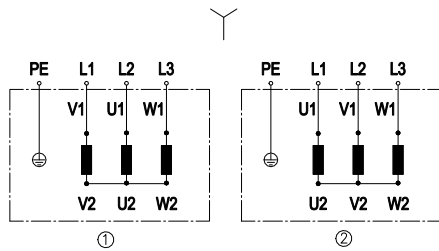

Change direction of rotation by reversing two phases

	Three-phase motor
Y	Star connection
1	Anti-clockwise operation
L1	= V1 = blue
L2	= U1 = black
L3	= W1 = brown
2	Clockwise operation
L1	= U1 = black
L2	= V1 = blue
L3	= W1 = brown
PE	green / yellow

# AC axial fan

sickled blades (S series), single inlet  
with guard grille for short nozzle

## Charts: Air flow 50 Hz

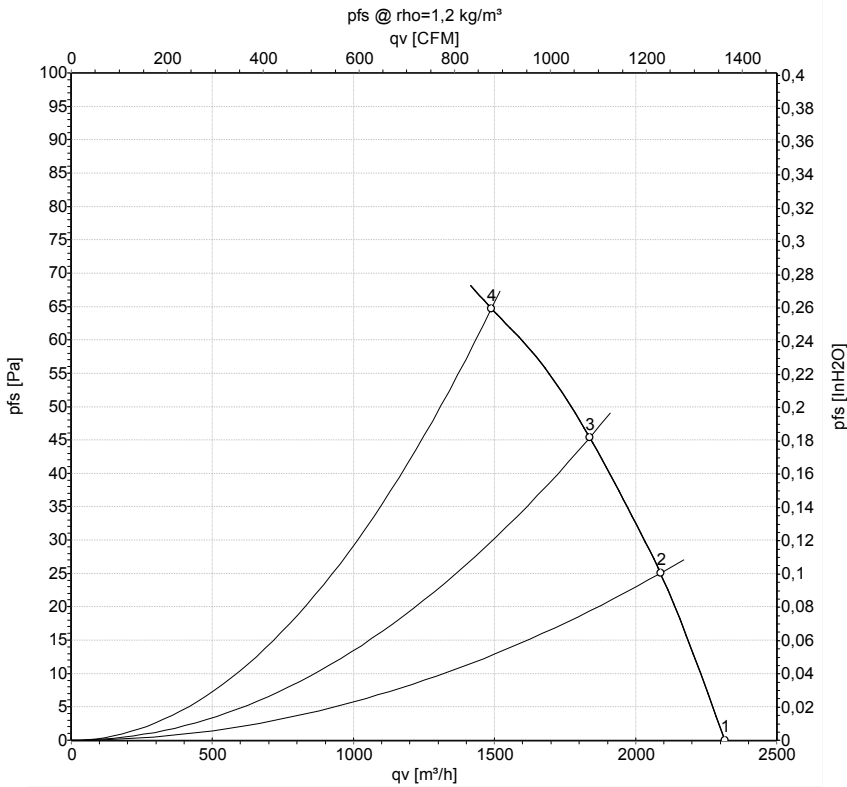

Measurement: LU-160546-1

Air performance measured as per ISO 5801 Installation category A. For detailed information on the measuring set-up, please contact ebm-papst. Suction-side noise levels:  $L_{wA}$  measured as per ISO 13347 /  $L_{pA}$  measured with 1m distance to fan axis. The values given are valid under the measuring conditions mentioned above and may vary according to the actual installation situation. With any deviation from the standard set-up, the specific values have to be checked and reviewed with the unit installed.

## Measured values

	Conn.	U	f	n	$P_e$	I	$L_{pA_{in}}$	$L_{wA_{in}}$	$q_v$	$p_{fs}$	$q_v$	$p_{fs}$
		V	Hz	min <sup>-1</sup>	W	A	dB(A)	dB(A)	m³/h	Pa	cfm	inH2O
1	Y	400	50	1375	84	0.24	57	63	2315	0	1365	0.00
2	Y	400	50	1360	90	0.24	54	61	2090	25	1230	0.10
3	Y	400	50	1350	94	0.24	51	58	1840	45	1080	0.18
4	Y	400	50	1330	100	0.25	50	58	1490	65	875	0.26

Conn. = Connection · U = Supply voltage · f = Frequency · n = Speed (rpm) ·  $P_e$  = Power input · I = Current draw ·  $L_{pA_{in}}$  = Sound pressure level inlet side ·  $L_{wA_{in}}$  = Sound power level inlet side  
 $q_v$  = Air flow ·  $p_{fs}$  = Pressure increase



# AC axial fan

sickled blades (S series), single inlet  
with guard grille for short nozzle

## Charts: Air flow 60 Hz

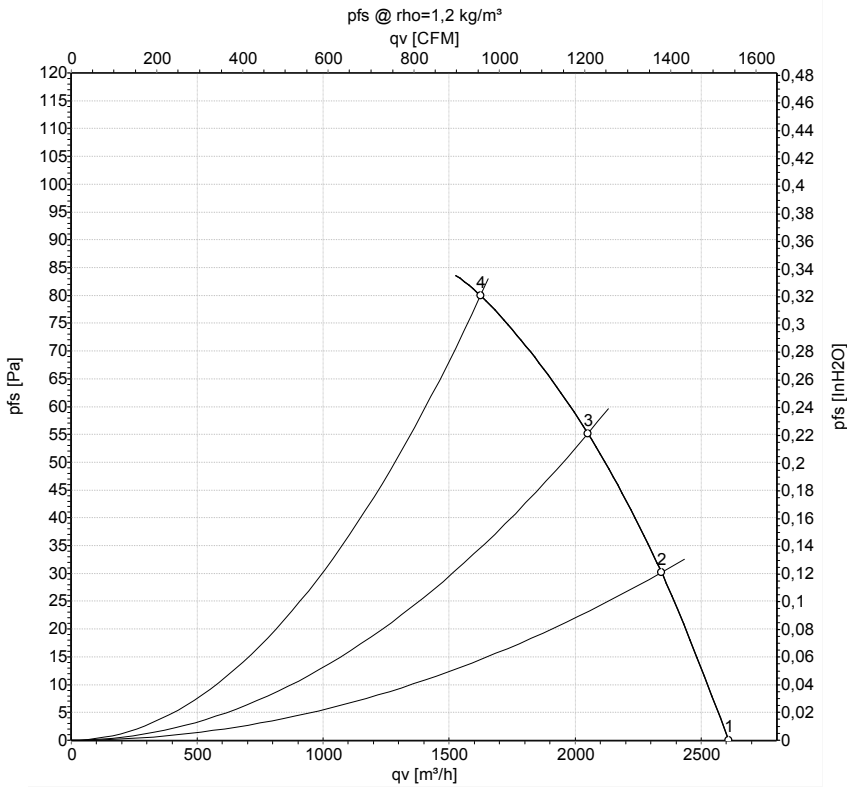

Measurement: LU-160727-1

Air performance measured as per ISO 5801 Installation category A. For detailed information on the measuring set-up, please contact ebm-papst. Suction-side noise levels:  $L_{wA}$  measured as per ISO 13347 /  $L_{pA}$  measured with 1m distance to fan axis. The values given are valid under the measuring conditions mentioned above and may vary according to the actual installation situation. With any deviation from the standard set-up, the specific values have to be checked and reviewed with the unit installed.

## Measured values

	Conn.	U	f	n	$P_e$	I	$L_{pA_{in}}$	$L_{wA_{in}}$	$q_v$	$p_{fs}$	$q_v$	$p_{fs}$
		V	Hz	min <sup>-1</sup>	W	A	dB(A)	dB(A)	m³/h	Pa	cfm	inH2O
1	Y	400	60	1545	108	0.22	59	66	2610	0	1535	0.00
2	Y	400	60	1520	116	0.23	57	64	2345	30	1380	0.12
3	Y	400	60	1495	122	0.23	55	61	2050	55	1205	0.22
4	Y	400	60	1460	135	0.25	53	61	1625	80	955	0.32

Conn. = Connection · U = Supply voltage · f = Frequency · n = Speed (rpm) ·  $P_e$  = Power input · I = Current draw ·  $L_{pA_{in}}$  = Sound pressure level inlet side ·  $L_{wA_{in}}$  = Sound power level inlet side  
 $q_v$  = Air flow ·  $p_{fs}$  = Pressure increase

