

www.fine-tek.com

Magnetic Float Level Switch



INTRODUCTION

PRINCIPLE

The single unit or multiple reed switch units are housed tightly in stainless steel or engineering plastic stem, and the permanent magnet is sealed into the middle of the specified float ball(s). You can mount the float ball to penetrating through the stem, then the liquid buoyancy will deliver the float ball up and down at the specified position by graduating rings.

When the float internal magnet approaches the reed switch, it will actuate the reed switch contact point to create an open or close circuit. We can apply such on-off output signals to reach liquid level controlling and monitoring purpose. The figures below show the float orientations on N.O. (Normal Open) and N.C. (Normal Close).

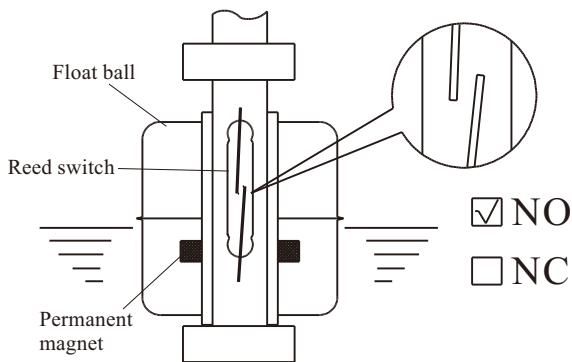

Rising float ball to actuate the reed switch

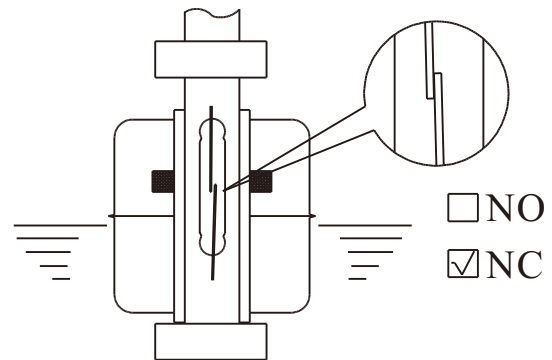

Rising float ball to switch off.

FEATURES

- ★ Multiple points measuring, multiple level points could be for custom-made.
- ★ Employing the magnet to actuate the reed switch requires no power. Life expectancy of each contact can reach up to 2 million times.
- ★ All output signal wiring are simplified in same junction box (housing) to economize the external wiring construction.
- ★ FC(D) type magnetic float level switches are more cost-effective than other level switches in terms of multiple points.
- ★ The housing protection is at least IP65.
- ★ Rugged construction and multiple options for materials from engineering plastics as PVDF, PP, PVC, and stainless steels such as SUS304, SUS316, float switches can be applied to versatile applications in chemical corrosion of acidity and alkalinity liquid, solvents or oil fuels.
- ★ The reed switch and lead wire are isolated with liquids absolutely. All stainless steel switches are applicable to high pressure and high temperature environment.

APPLICATIONS

Shipbuilding Industry, Generator Facilities, Petrochemical Industry, Food/Beverage Industry, Waste Water/Water Purified Facilities, Electronic Industry, Dyeing and Finishing Industry, Chemical Industry, Rubber/ Plastic Industry, Hydraulic.

SPECIFICATION

Tube Type	Material	Switching Contact from	Switching Capacity Max.	Switching Voltage Max.	Switching Current Max.	Carry Current Max.
OD8	SUS	SPST	50W	300Vac/350Vdc	0.5A	2.5A
	PVC	SPDT	20W	150Vac/200Vdc	1A	2A
OD9.5	SUS	SPST	50W	300Vac/350Vdc	0.5A	2.5A
		SPDT	20W	150Vac/200Vdc	1A	2A
OD12.7	SUS	SPST	50W	300Vac/350Vdc	0.5A	2.5A
		SPDT	50W	400Vac/1000Vdc	1A	2A
OD16	PVDF	SPST	50W	300Vac/350Vdc	0.5A	2.5A
		SPDT	50W	400Vac/1000Vdc	1A	2A
OD17.2	PP	SPST	50W	300Vac/350Vdc	0.5A	2.5A
		SPDT	50W	400Vac/1000Vdc	1A	2A

※ Reed switches of UL approval are 240Vac/ 200Vdc, 50w,0.5A.

APPLICATION FIELDS OF FLOAT

Environments Float	Working Temp.	Pressure Rating	Acid	Alkaline	Oil	Solvent
SUS304	- 20°C~120°C (200°C Max.)	10~ 35kg/cm ²	×	△	◎	◎
SUS316	- 20°C~120°C (200°C Max.)	10~ 35kg/cm ²	△	○	◎	◎
Polypropylene	-20°C~80°C	5kg/cm ²	○	○	○	×
PVDF	-20°C~120°C	5kg/cm ²	◎	◎	○	○

Note: ◎ = Excellent ○ = Good △ = Acceptable × =Not good (S10 resistance:50 kg)

CHEMICAL RESISTANCE

● Excellent ○ Good △ Fair × Corroded

Chemical	Concentration %	Temp		Plastic				Rubber		Stainless	
		°C	°F	PVC	PP	PVDF	PTFE	NBR	304	316	
Ammonia Water NH ₄ OH	10	40	104	●	●	●	●	○			
	10	80	176		○	●	●				
Aque Regia 3HCl+HNO ₃	10	40	104	△	△	●	●				
	10	80	176			●	●				
Benzene C ₆ H ₆	Pure	40	104	×	△	○	●				
		80	176			△	●				
Bleaching Liquor Ca(ClO) ₂	5	40	104	●		●	●				
	5	80	176			●	●				
	20	40	104	●		●	●				
	20	80	176			●	●				
Boric Acid H ₃ BO ₃	Satu	40	104	●	●	●	●	●			
		80	176		●	●	●	○			
Brine		40	104	●	●	●	●	●			
		80	176		●	●	●				
Butadiene CH ₂ =CH=CH=CH ₂	Gas	40	104	●		●	●	△			
		80	176			●	●				
Butane CH ₃ (CH ₂) ₂ CH ₃	Gas	40	104	●	●	●	●				
		80	176		●	●	●				
Nitric Acid HNO ₃	10	40	104	●	●	●	●	●	●	●	
	10	80	176	×	○	●	●		●	●	
	30	40	104	●	●	●	●		●	●	
	30	80	176	×	○	●	●		●	●	
	50	40	104	○	○	●	●		●	●	
	50	80	176	×	×	○	●				
	70	40	104	○	×	●	●		○	●	
	70	80	176	×		○	●				
	98	40	104			○	○				
	98	80	176				△				
Oxalic Acid HOOC ₂ COOH	20	40	104	●	●	●	●	●		△	
	20	80	176		●	●	●				
	50	40	104	●	●	●	●			△	
	50	80	176		●	●	●				
Phosphoric Acid H ₃ PO ₄	10	40	104	●	●	●	●	●	●	●	
	10	80	176		○	●	●	△	●	●	
	50	40	104	●	●	●	●	●	●	●	
	50	80	176		△	○	○	×	●	●	
	80	40	104	●	○	●	●	○	●	●	
	80	80	176		△	●	●		●	●	
Butane CH ₃ (CH ₂) ₂ CH ₃	Gas	40	104	●	●	●	●				
		80	176		●	●	●				
Sodium Hydroxide NaOH	15	40	104	●	●	●	●	●	●	●	
	15	80	176		○	△	●	△	×	×	
	30	40	104	●	●	●	●	●	●	●	
	30	80	176		○	△	●	●	×	×	
	50	40	104	●	●	○	●	●	●	●	
	50	80	176		○	×	●	●	×	×	
	70	40	104	○	○	○	●				
	70	80	176		○	×	●				

Chemical	Concentration %	Temp		Plastic				Rubber		Stainless	
		°C	°F	PVC	PP	PVDF	PTFE	NBR	304	316	
Sodium Hypochlorite NaClO	3	40	104	●	○	●	●			△	○
	3	80	176								
	5	40	104	●	○	●	●			△	○
	5	80	176								
	7	40	104	●	△	○	●			×	×
	7	80	176								
	10	40	104	●	△	●	●			×	×
10	80	176									
13	40	104	●	△	●	●				×	
13	80	176									
Sulfuric Acid H ₂ SO ₄	10	40	104	●	●	●	●	●	●	●	●
	10	80	176		●	●	●	○	○	○	
	30	40	104	●	●	●	●	●	×	×	
	30	80	176		●	●	●	○	×	×	
	50	40	104	●	●	●	●	○	×	×	
	50	80	176		●	●	●	△	×	×	
	60	40	104	●	●	●	●	●	×	×	
	60	80	176		○	●	●	○	×	×	
	70	40	104	●	●	●	●	○	×	×	
	70	80	176		○	●	●	△	×	×	
	80	40	104	●	●	●	●	○	×	×	
80	80	176		○	●	●	△				
90	40	104	○	●	●	●	△	×	×		
90	80	176		○	●	●	△				
98	40	104	△		●	○		○	○		
98	80	176			△	○					
Toluene C ₆ H ₅ CH ₃		40	104		△	●	●				
		80	176				○				
Chlorine Gas Cl ₂	Wet	40	104	○		●	●				
	Wet	80	176			△	●				
	Dry	40	104	●		●	●				
	Dry	80	176			●	●				
Chromic Acid H ₂ CrO ₄	10	40	104	●		●	●				
	10	80	176			●	●				
	20	40	104	△		●	●				
	20	80	176			●	●				
	40	40	104	△		●	●				
	40	80	176			●	●				
	50	40	104	×		●	●				
	50	80	176			△	●				
Hydrochloric Acid HCl	15	40	104	●	●	●	●	○			
	15	80	176		●	●	●				
	25	40	104	●	●	●	●	×			
	25	80	176		●	●	●				
	35	40	104	●	●	●	●	×			
	35	80	176		○	●	●				
	38	40	104	●	●	●	●	×			
	38	80	176		○	●	○				

● Excellent ○ Good △ Fair × Corroded

Chemical	Concentration %	Temp		Plastic				Rubber	Stainless	
		°C	°F	PVC	PP	PVDF	PTFE	NBR	304	316
Citric Acid $C_6H_8O_7$	10	40	104	●	●	●	●	●	●	●
	10	80	176		○	●	●	●		
Gasoline	10	40	104	●		●	●			
	10	80	176			●	●			
Diesel Fuels		40	104			●	●		●	●
		80	176			●	●		●	●
Ethyl Alcohol C_2H_5OH	Pure	40	104	●	●	●	●	●	○	○
		80	176		○	●	●	○		
Formic Acid $HCOOH$	90	40	104	○	○	●	●			
		80	176			●	●			
Hydrofluoric Acid HF	Dilute	40	104	●	○	●	●			
		80	176		○	●	●			
	30	40	104	○	○	●	●			
		80	176	×	○	●	●			
		40	104	△	○	●	●			
		80	176		○	●	●			
		40	104	△	○	●	●			
		80	176		○	●	●			
Hydrogen peroxide H_2O_2	5	40	104	●	●	●	●		○	●
	5	80	176		○	●	●			
	20	40	104	●	●	●	●			
	20	80	176		○	●	●			
	30	40	104	○	○	●	●			
	30	80	176		△	●	●			
	50	40	104	△	×	●	●			
	50	80	176			●	●			
Isopropyl Alcohol $(CH_3)_2CHOH$	Pure	40	104	●	●	●	●	○		
		80	176			●	●			
Kerosene		40	104	●	○	●	●			
		80	176			●	●			
Methyl Alcohol CH_3OH		40	104	○	●	●	●	△		
		80	176		○	●	●			
Methyl Ethyl Ketone $CH_3COC_2H_5$		40	104		△		●			
		80	176				●			
Potassium Chromate K_2CrO_4		40	104	●	●	●	●	●		
		80	176		○	●	●	○		

CONTACT PROTECTION CIRCUITS

INDUCTIVE LOADS

When using a reed switch with inductive loads such as motors, relays, solenoids, etc., The contact will be subjected to a high induced voltage during opening of the contact (load circuit).

Such high induced voltage (transients) may cause damages to the reed switch or significantly reduce its life. Therefore, protective circuits such as: RC (snubber), varistors or clamping diodes are recommended.(refer to Fig.1)

(Fig.1)

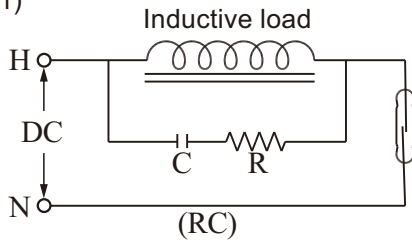

$$C = \frac{I^2}{10} \text{ (uF)}$$

$$R = \frac{E}{10I(1 + \frac{50}{E})}$$

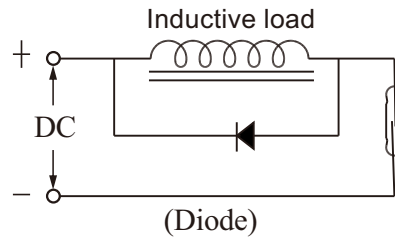
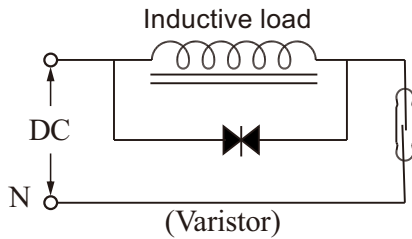

★ It is prohibited to connect directly with any solenoid valve, motor or magnetic switch.

CAPACITIVE LOADS

When using a reed switch with capacitive loads such as capacitors, incandescent lamps or long cables, the contact will be subjected to a high surge (inrush) current.

Therefore, protective circuits such as: surge suppressors or current limiting resistors are recommended.(refer to Fig.2)

(Fig.2)

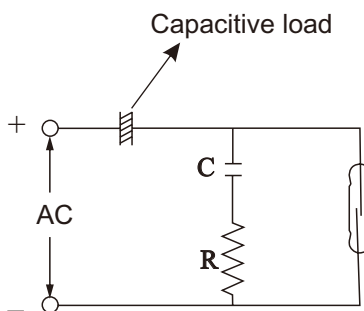

Parallel connection of RC circuit and switch will surge current bypass.

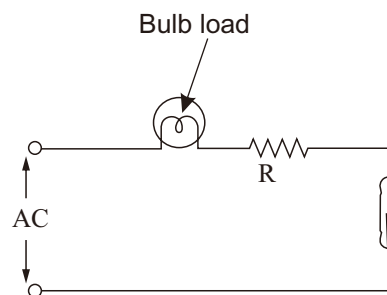

Series connection of resistance and switch limit surge current.

HOUSING SPECIFICATION

B

Material : Aluminum
Enclosure : IP65
Terminals : 2~12
Max.Temp.: -20°C ~200°C

C

Material : PP+Fiber
Enclosure : IP65
Terminals : 2~12
Max.Temp.: -20°C ~80°C

D

Material : Aluminum
Enclosure : IP65
Terminals : 2~12
Max.Temp.: -20°C ~200°C

E

Material : Aluminum
Enclosure : IP65
Terminals : 2~6
Max.Temp.: -20°C ~200°C

G

Material : PC
Enclosure : IP65
Terminals : 2~6
Max.Temp.: -20°C ~80°C

H

Material : Aluminum
Enclosure : IP65
Terminals : 2~12
Max.Temp.: -20°C ~100°C

K Enclosure Explosion-proof

Material : Aluminum
Enclosure : INERIS 09 ATEX 0049
II 2GD Ex d IIC T4~T6
Terminals : 2~6
Max.Temp.: -20°C ~100°C

L Enclosure Explosion-proof

Material : Aluminum
Enclosure : INERIS 09 ATEX 0049
II 2GD Ex d IIC T4~T6
Terminals : 2~6
Max.Temp.: -20°C ~90°C

M

Material : SUS316
Enclosure : IP65
Terminals : 2~6
Max.Temp.: -20°C ~200°C

*For flow switch series.

*For side-mounting float series.

N

Material : SUS316
Enclosure : IP65
Terminals : 2~6
Max.Temp.: -20°C ~200°C

X

Material : Aluminum
Enclosure : IP65
Terminals : 2~6
Max.Temp.: -20°C ~100°C

Cable Conduit Ex d IIC

Material: Washer ---NBR
Body— SUS 304

29-1104

$\phi_{Max}=14$
 $\phi_{Min}=10$

29-1108

$\phi_{Max}=10$
 $\phi_{Min}=6.5$

Remark 1 : Cable conduit is optional. Contact us if needed.
Remark 2 : Complete unit with D&N housing suffix are ATEX compliant.
See page.20 for detail model selection.

FLOAT SPECIFICATIONS

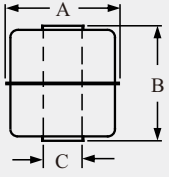
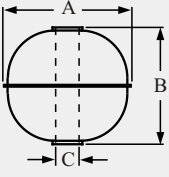
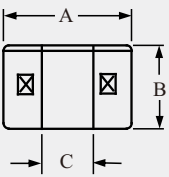
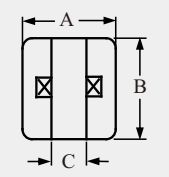
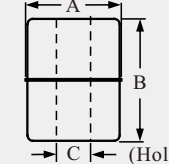
MODEL	TYPE	$\phi A \times B \times \phi C$	S.G.	Max. Pressure (kg/cm ²)	Weight (g)	Material/Color	Max. Temp. (°C)
	S1	28x28x9.5	E>0.7	10	8	SUS 316 / 316L	200
	S3	45x55x15	E>0.65	12	37.6	SUS 316	200
	S6	75x108x20	E>0.5	10	165	SUS 316	200
	S13	38x50x15	E>0.62	12	22.9	SUS 316L	200
	S2	41x38x11	E>0.7	35	19.5	SUS 316	200
	S4	52x52x15	E>0.55	30	33.4	SUS 316	200
	S5	75x73x20	E>0.70	30	102.4	SUS 316	200
	S7	30x28x9.5	E>0.75	25	8	SUS 316 / 316L	200
	S8	100x100x20	E>0.5	15	249.7	SUS 304	200
	S9	150x150x30	E>0.45	15	534	SUS 304	200
	S10	30x32x9.5	E>0.75	50	8.6	SUS 316	200
	S11	28x32x9.5	E>0.82	30	8.1	SUS 316	200
 <p>(Hollow)</p>	P1	25x15x10	E>0.65	4	3.5	PP / white black	80
	P2	25x25x10	E>0.7	4	5	PP / white black	80
	P3	48x45x18.5	E>0.6	5	35.5	PP / black	80
	P4	20x25x10	E>0.7	4	3.7	PP / black	80
	P5	20x20x8.1	E>0.75	4	4	PP / black	80
	P8	18.2x15.3x7.2	E>0.8	4	1.82	PP / black	80
 <p>(Foam)</p>	Q6	20x20x7.5	E>0.75	ATM	3.5	PP / white	80
	Q7	25x25x8.8	E>0.7	ATM	6.7	PP / white	80
	N1	25x15x10	E>0.5	ATM	2.7	NBR / black	100
	N2	18.5x26x10	E>0.7	ATM	3.3	NBR / black	100
	N4	17.5x25x10	E>0.65	ATM	2.5	NBR / black	100
	N5	30x45x12.8	E>0.5	ATM	11.5	NBR / black	100
 <p>(Hollow)</p>	F2	42x44x14	E>0.45	5	18.5	PP	80
	F3	45x45x20	E>0.65	5	35.7	PP	80
	F4	48x62x18	E>0.8	5	65.3	PVDF	120

※ S5 float: E>0.7 for FC; E>0.61 for FG

※ F4 float: E>0.8 for FC; E>0.75 for FG

ORDER SPECIFIED

THE PROPERTIES BETWEEN LIQUID AND FLOAT

Please choose the proper float subject to above independent specified terms and chemical characters.

1. **Temperature:** PVDF Max. 120°C,
PP Max. 80°C,
SUS304/ 316 Max. 200°C
2. **Pressure:** Max. pressure of plastic floats is 5kg/cm²
and max. pressure of SUS floats is 35kg/cm²
(S10 floats can reach 50kg/cm²)
3. **Viscosity:** Please choose smaller S.G. with
greater diameter floats to cope with
high viscosity liquid applications.
4. **Chemical:** Please use plastic float for acid/
alkaline corrosion of chemical
applications. PVDF float is noted
for high temperature cases.
5. **Benzine:** Please choose stainless steel floats
to apply in any gasoline, fuel oil,
petroleum application.
6. **S.G.:** The float S.G. Must be smaller than the
liquid, otherwise, the liquid buoyancy
can not deliver the float upward.

It is requested the minimum interval for a single ball driving dual actuated positions (D) or neighboring two balls (B), or from the bottom to the lowest ball interval (C) or from the mounting position to the first ball (A), otherwise, there will be some magnetic mutually interference involved by insufficient interval. To ensure the defined distance, please see the data below:

A= Minimum distance from the mounting position to the highest actuation level.

B= Minimum distance between any two actuation levels.

C= Minimum distance from end of the lowest level.

D= Minimum distance between two actuation levels by one float.

E= Screw length

FLOAT TYPE	S1	S2	S3	S4	S5	S6	P1	P2	P3	F4
A(mm)	25	32	40	39	50	70	23	27	47	55
B(mm)	50	64	82	78	99	136	44	55	85	98
C(mm)	25	32	40	39	50	70	23	31	43	50
D(mm)	30	40	55	50	65	70	30	30	45	65

SCREW	1/2"	3/4"	1"	1-1/4"	1-1/2"	2"	2-1/2"	3"
(E) (mm)	14	16	19	22	22	22	25	27

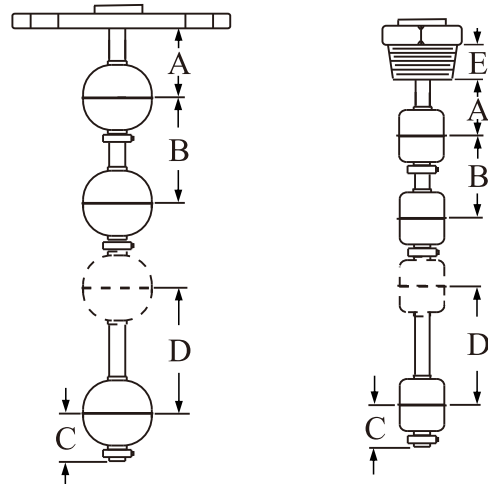

THREAD /FLANG SIZE SELECTION

Float type	Material	Float dimensions	Thread size for direct installation	Flange size for direct installation	
				SCH40S	SCH80S
P 1	P . P .	Ø25×15	1"PF or PT	1"×5K, 10K	1-1/4"×5K,10K
P 2	P . P .	Ø25×25	1"PF or PT	1"×5K, 10K	1-1/4"×5K,10K
P 3	P . P .	Ø48×45	2"PF or PT	2"×5K, 10K	2"×5K, 10K
P 4	P . P .	Ø20×25	3/4"PF or PT	3/4"×5K,10K	1"×5K, 10K
N 1	NBR	Ø25×15	1"PF or PT	1"×5K, 10K	1-1/4"×5K,10K
N 2	NBR	Ø18.5×26	3/4"PF or PT	3/4"×5K,10K	1"×5K, 10K
N 4	NBR	Ø17.5×25	1/2"PF or PT	1/2"×5K,10K	3/4"×5K,10K
N 5	NBR	Ø30×45	1-1/4"PF or PT	1-1/4"×5K,10K	1-1/2"×5K,10K
F 2	P . P .	Ø42×44	1-1/2"PF or PT	2"×5K, 10K	2"×5K, 10K
F 3	P . P .	Ø45×45	2"PF or PT	2"×5K, 10K	2"×5K, 10K
F 4	PVDF	Ø48×62	2"PF or PT	2"×5K, 10K	2"×5K, 10K
S 1	SUS	Ø28×28	1"PF or PT	1-1/4"×5K,10K	1-1/4"×5K,10K
S 2	SUS	Ø41×38	1-1/2"PF or PT	1-1/2"×5K,10K	2"×5K, 10K
S 3	SUS	Ø45×55	2"PF or PT	2"×5K, 10K	2"×5K, 10K
S 4	SUS	Ø52×52	2"PF or PT	2"×5K, 10K	2-1/2"×5K,10K
S 5	SUS	Ø75×73	3"PF or PT	3"×5K, 10K	3-1/2"×5K,10K
S 6	SUS	Ø75×108	3"PF or PT	3"×5K, 10K	3-1/2"×5K,10K
S 7	SUS	Ø30×28	1-1/4"PF or PT	1-1/4"×5K,10K	1-1/2"×5K,10K
S10	SUS	Ø30×32	1-1/4"PF or PT	1-1/4"×5K,10K	1-1/2"×5K,10K
S11	SUS	Ø28×32	1"PF or PT	1-1/4"×5K,10K	1-1/4"×5K,10K
S13	SUS	Ø38×50	1-1/4"PF or PT	1-1/4"×5K,10K	1-1/2"×5K,10K

※Contact Fine Tek sales team if protection tube is required.

MODEL / NUMBER ORDER CODE COMPARISON TABLE

Model Number	Order Code
FCCFQ6F44	FCX10000-ACAAB2012C24F44
FCCFQ5P34	FCX10000-ACAAB2012D18P34
FCCFN6F44	FCX10000-ACAAB2422C24F44
FCCFN5P34	FCX10000-ACAAB2422D18P34

ANTI-CORROSION SCREW TYPE / FLANGE TYPE

Housing material apply by PP, wet portion material options in PP, PVDF, specially applicable for chemical applications against corrosive environments.

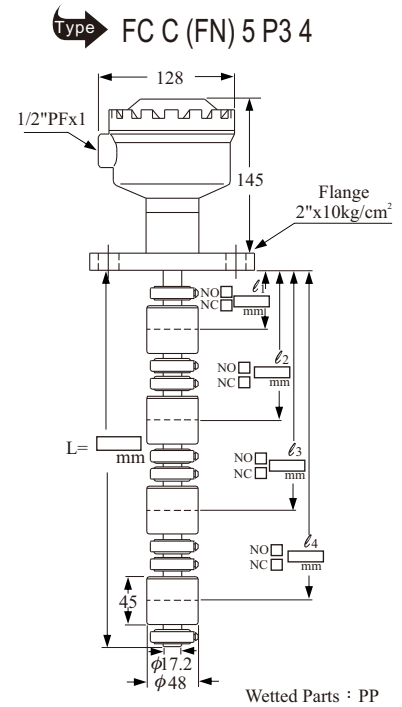
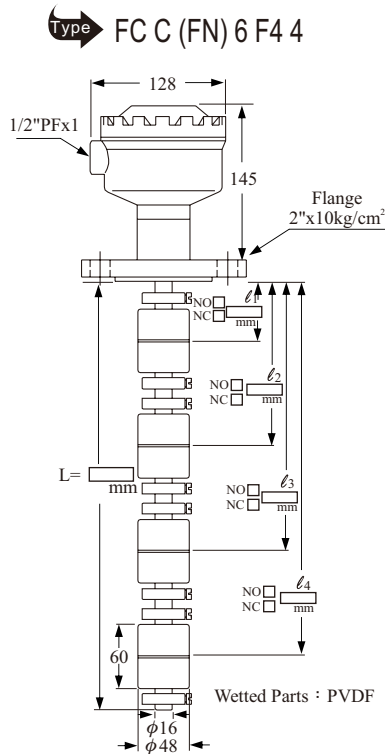
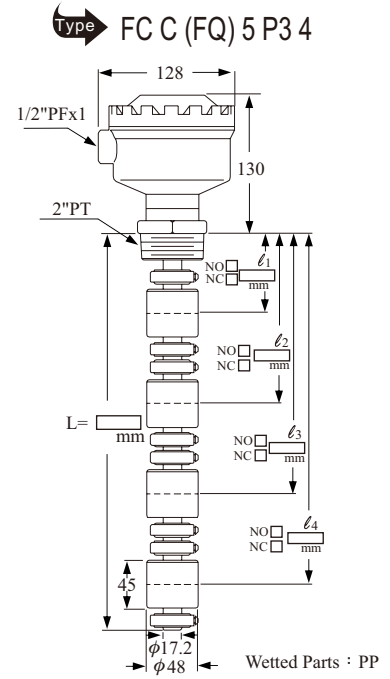
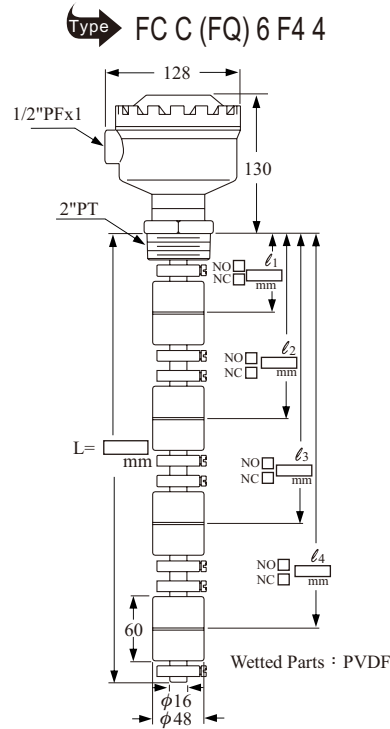

STANDARD FLANGE TYPE

The housing complies with the IP65 rating and can therefore be used in outdoor environment.

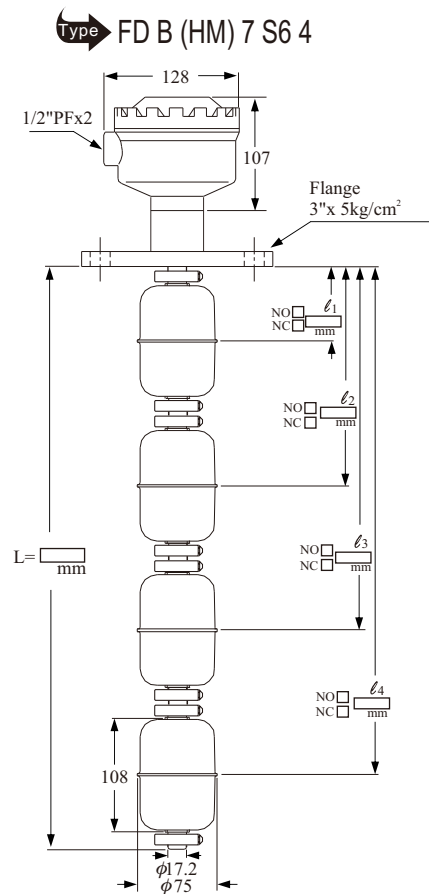
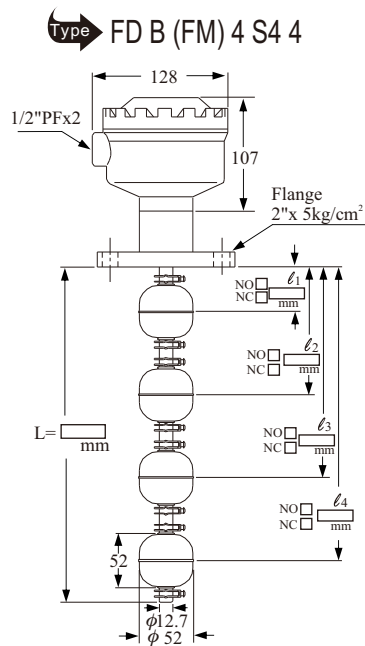
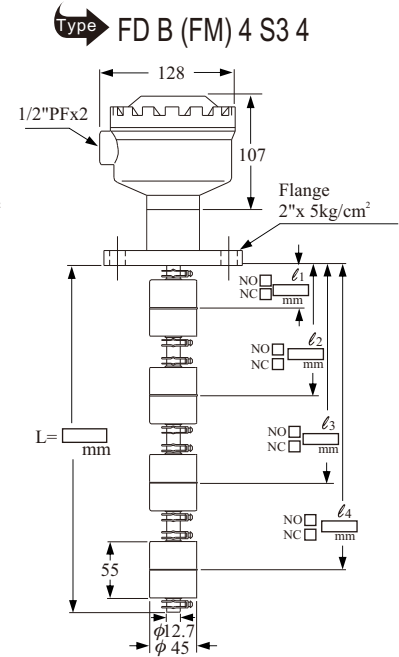
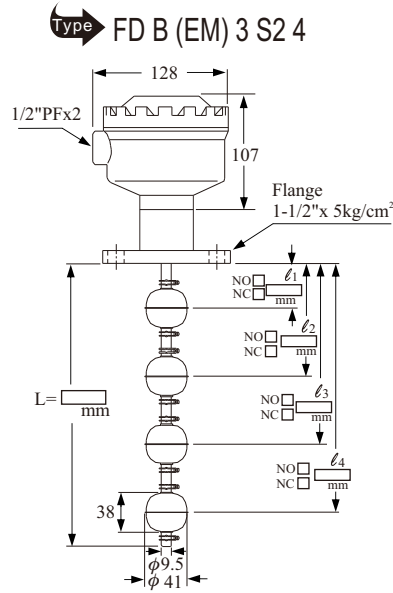

STANDARD SCREW TYPE

The housing complies with the IP65 rating and can therefore be used in outdoor environment.

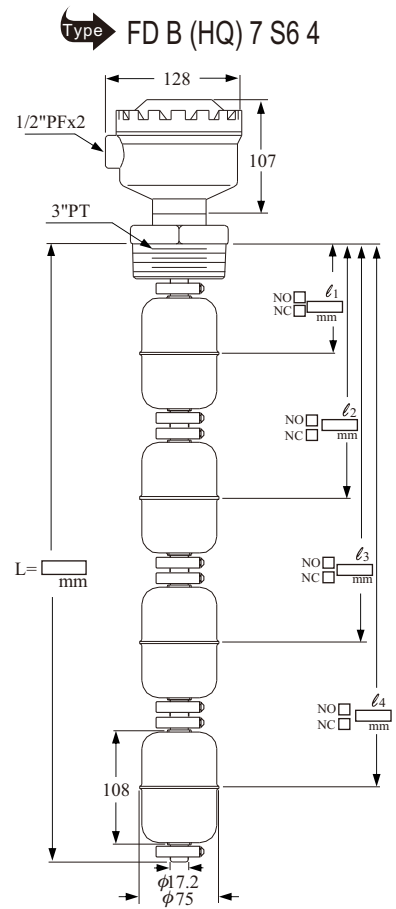
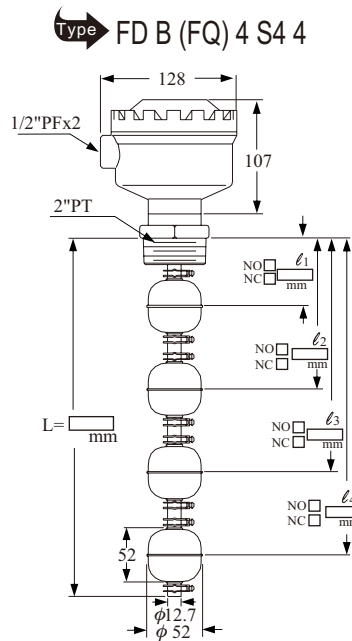
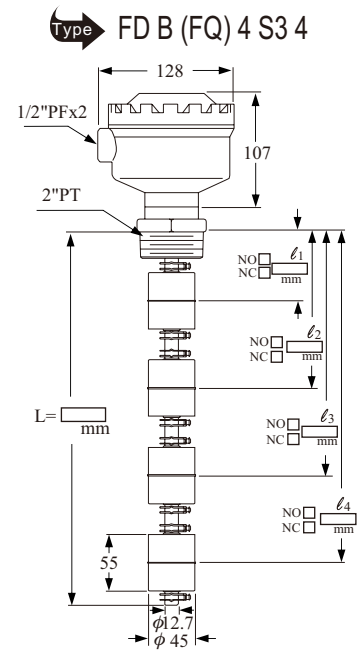
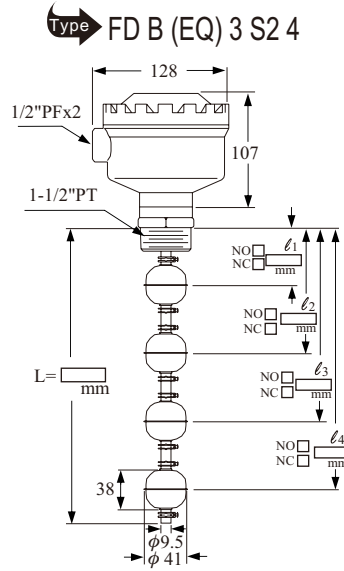

SCREW TYPE / FLANGE TYPE

The housing complies with the IP65 rating and can therefore be used in outdoor environment.



Type FD E (EM) 3 S2 3

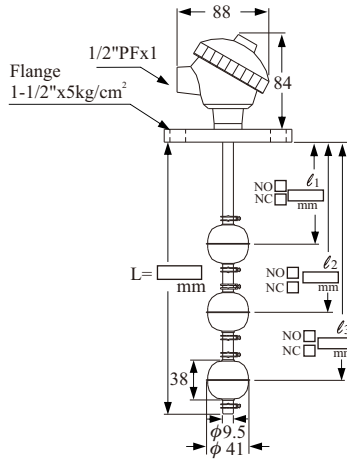

Type FD E (3M) 1 S1 3

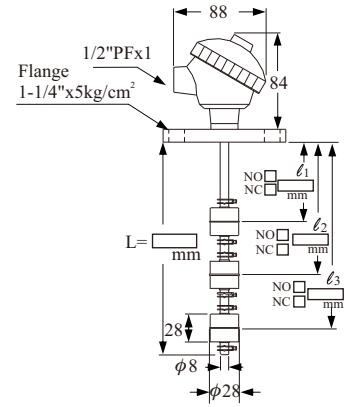

Type FD E (EQ) 3 S2 3

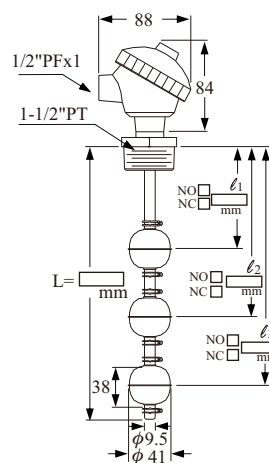

Type FD E (DQ) 1 S1 3

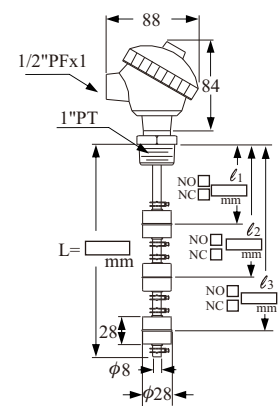

ENCLOSURE EXPLOSION PROOF

FLANGE TYPE

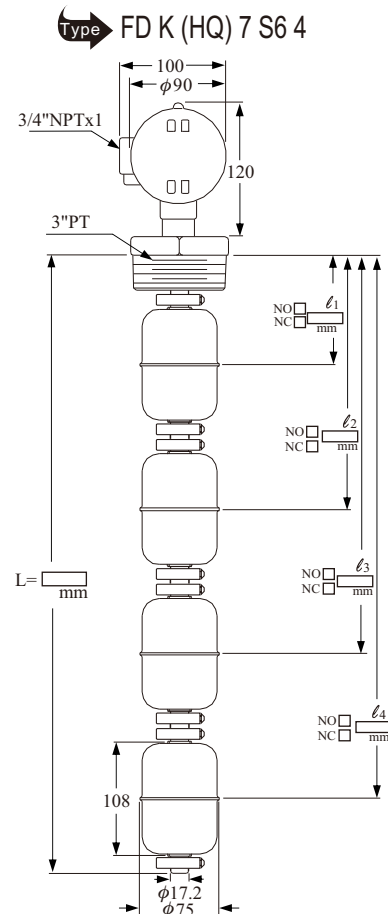
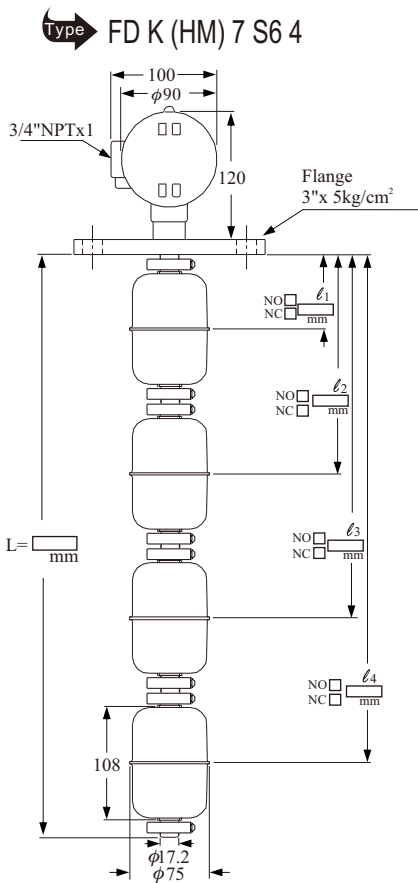
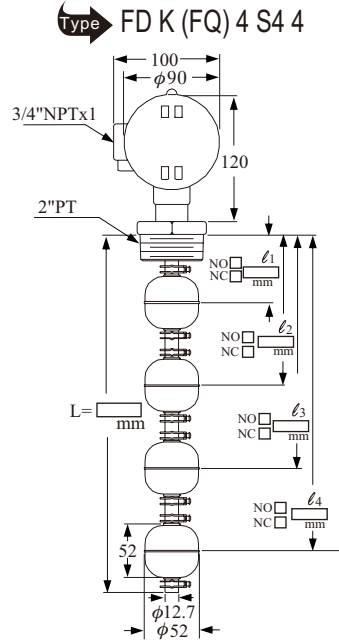
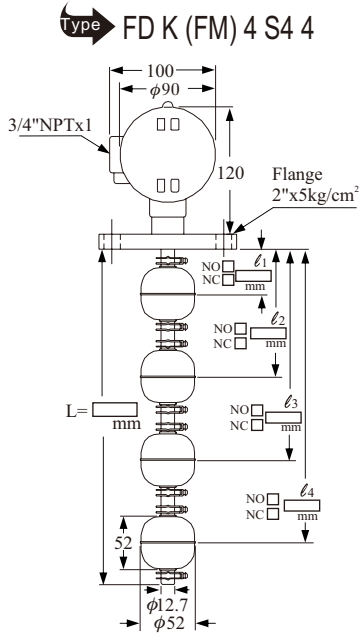

VERTICAL ADJUSTMENT TYPE

This is a special design for some liquid applications requiring monitoring different actuation levels frequently. The user needs only to loose the hexagon nut, then remove the mounted screw/ flange up or down to achieve the actuated level position adjustment.

- * Applicable at tank interior pressure under 5 kg/cm².
- * Standard specification 80°C, special order of max. 200°C available.
- * Switch contact: 20W/150Vac /250Vdc SPDT
50W/300Vac /350Vdc SPST
50W/220Vac /500Vdc SPST
50W/400Vac /1000Vdc SPDT
- * Customer specified flange/ screw acceptable.

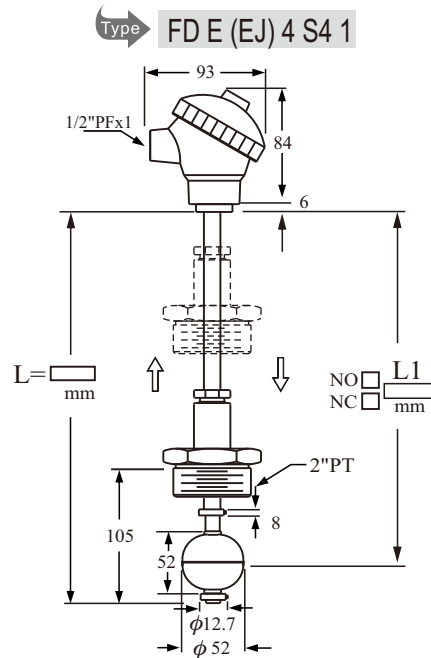

Connection	Pipe Diameter	Float Type
EJ=1-1/2"PT	3= $\phi 9.5$	S2= $\phi 41 \times 38$
FJ=2"PT	4= $\phi 12.7$	S4= $\phi 52 \times 52$
EK=1-1/2" 5kg/cm ²	3= $\phi 9.5$	S2= $\phi 41 \times 38$

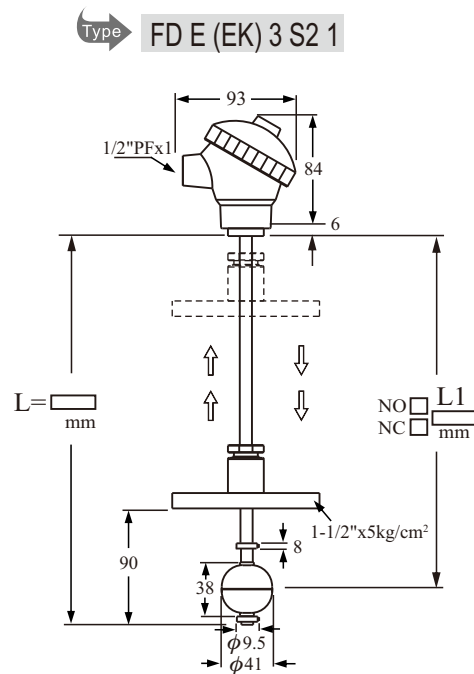

TEST ROD

GL Marine Approval 50885-04HH

FUNCTION

When the Test Rod is attached to a magnetic float level switch, user could test the performance of the magnetic switch directly by pulling the handle of the test rod on the top of the switch.

MATERIAL

1. Rod Connection: Bronze
2. Compressed Spring: Stainless Steel
3. Positioning Clip: Stainless Steel
4. Test Rod Stem: Stainless Steel

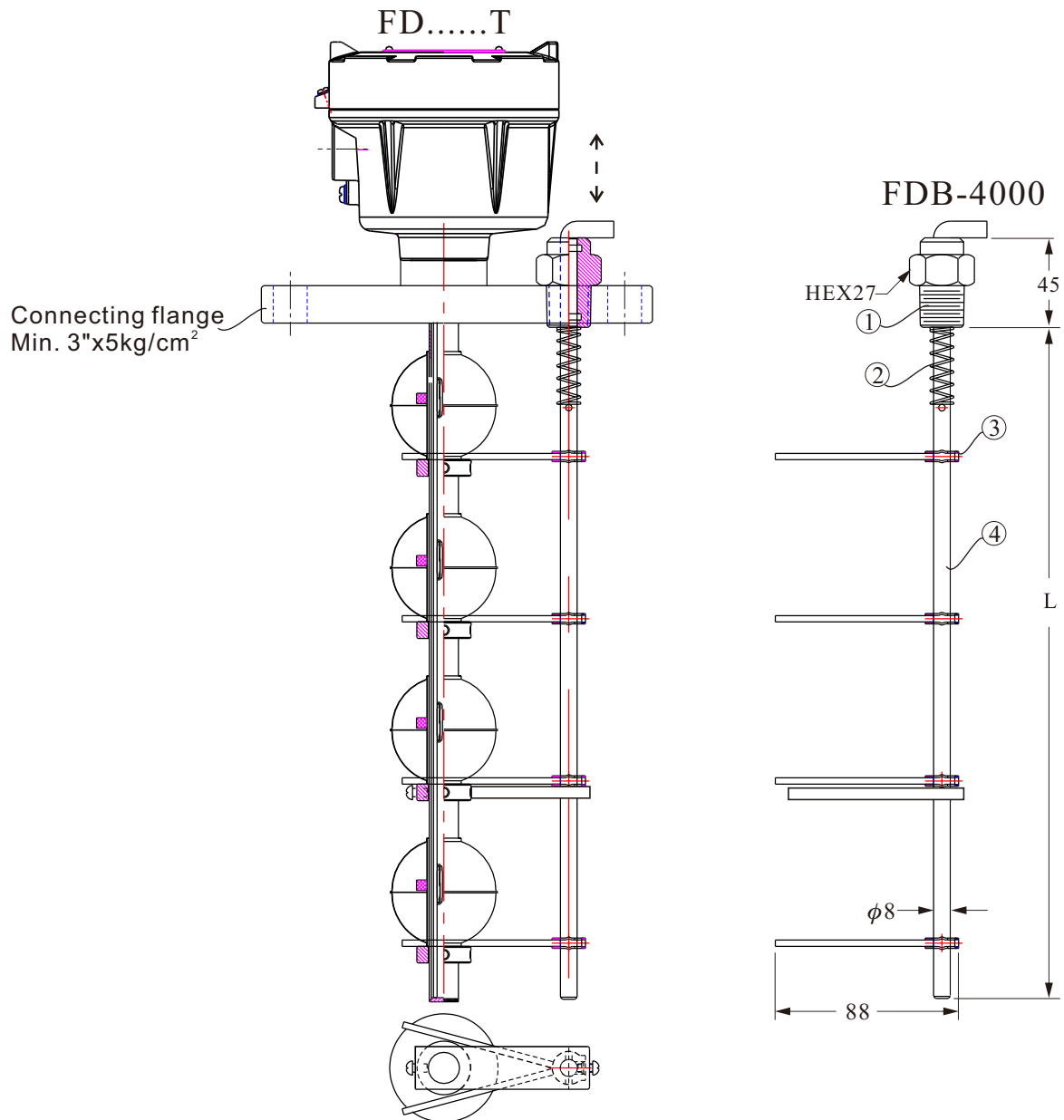

MARINE GRADE APPROVAL

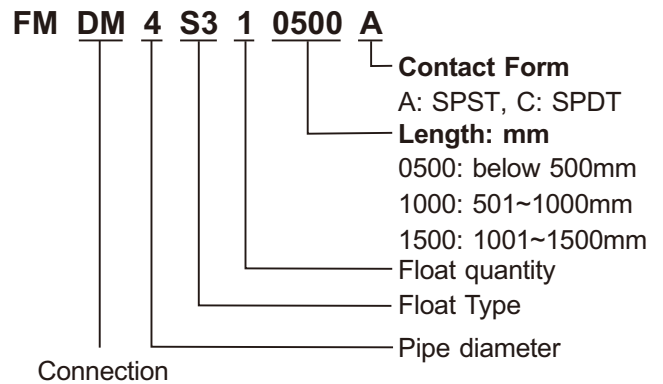
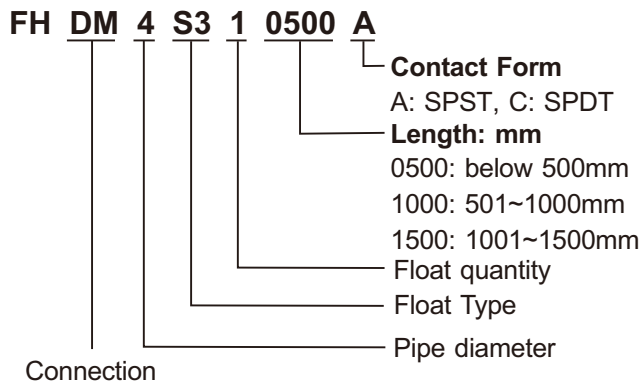
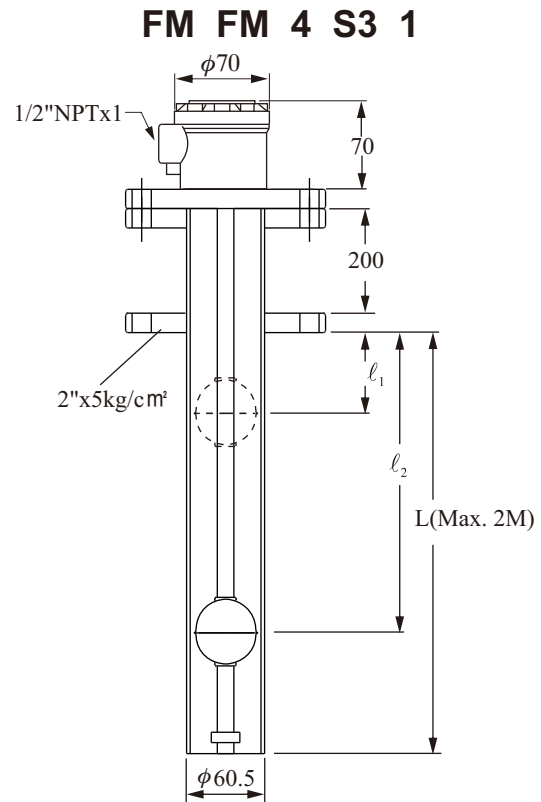
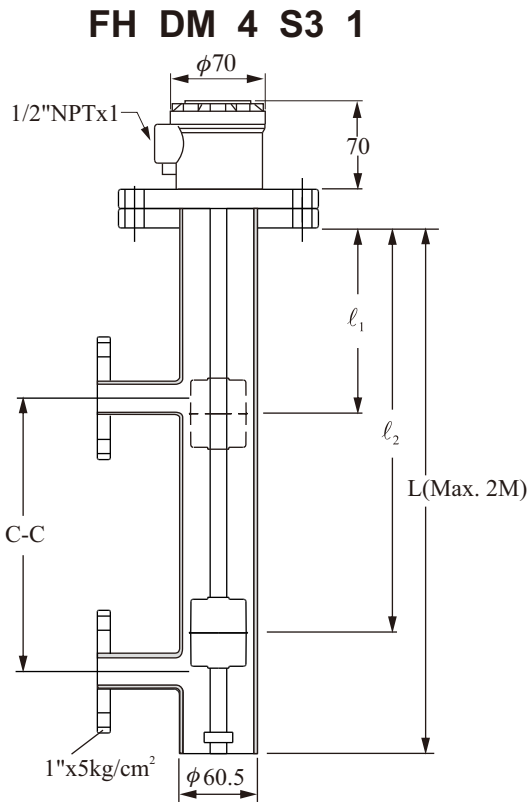

* Please specify the l_1 , l_2 , C-C and L while placing an order.
(Length from lower end of housing to center line of float ball)

Connection	Pipe Diameter	Float Type
DM=1"x 5kg/cm ²	4=φ12.7	S3=φ45x55
FM=2"x 5kg/cm ²	4=φ12.7	S4=φ52x52

* Special term for LR Marine approval: "Environmental test has been carried out but it is not applicable to use in the ship and offshore that type of screw fittings is used for pipe exceeding 51mm outer diameter".

EXPLOSION PROOF TYPE

FLANGE TYPE

Type → FD7 D FM 4 S4 4

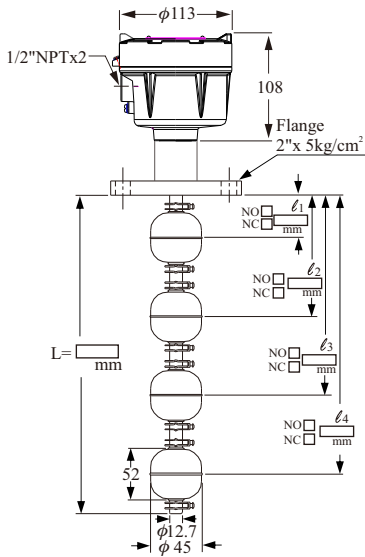

Type → FD7 D HM 7 S6 4

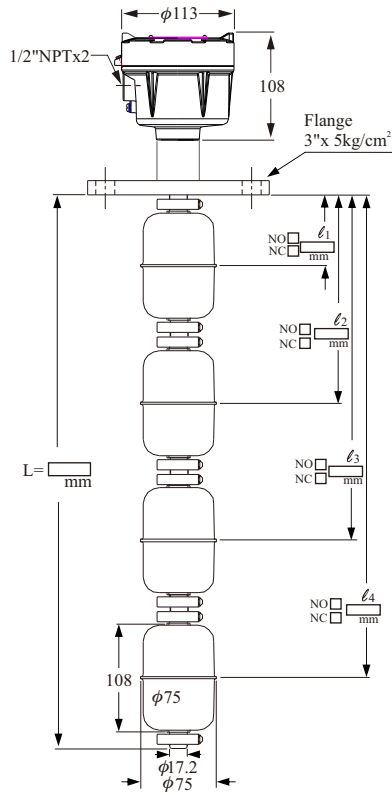

Type → FD7 N HM 7 S6 4

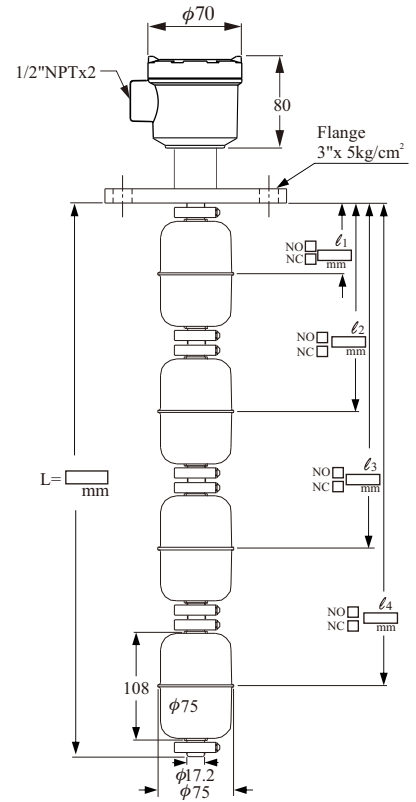

SCREW TYPE

Type → FD7 D FQ 4 S4 4

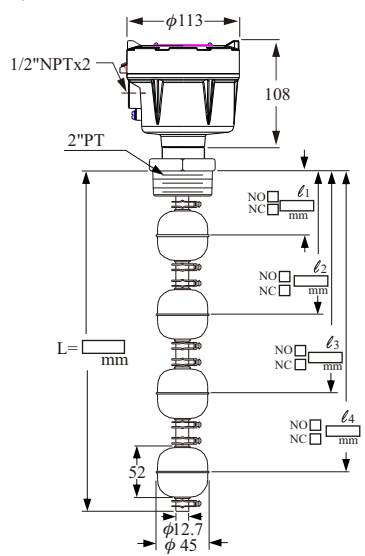

Type → FD7 D HQ 7 S6 4

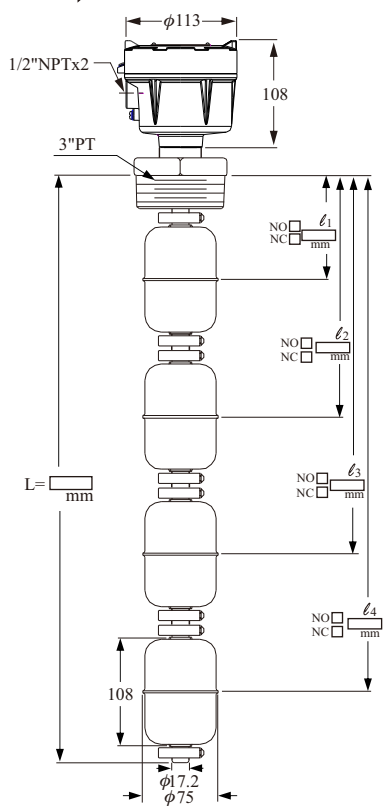

Type → FD7 N HQ 7 S6 4

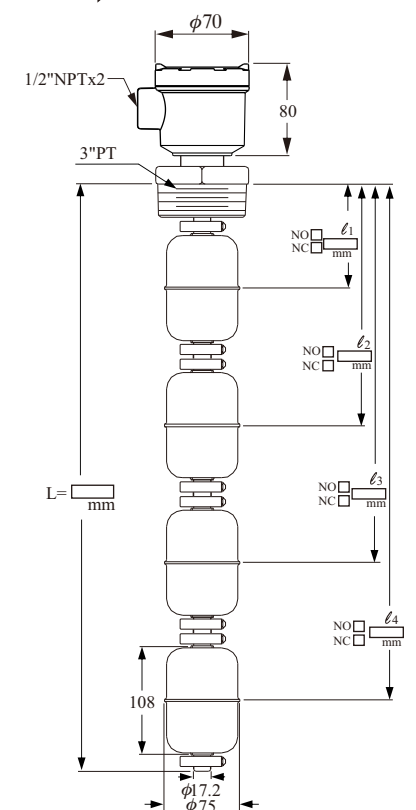

MODEL / NUMBER ORDER CODE COMPARISON TABLE

Model Number	Order Code
FDBEM3S24	FDX10000-ABAKB1401GMAS24
FDBFM4S34	FDX10000-ABAKB2402AMAS34
FDBFM4S44	FDX10000-ABAKB2402AMAS44
FDBHM7S64	FDX10000-ABAKB5402DMAS64
FFDBEQ3S24	FDX10000-ABAAB1011GMAS24
FDBFQ4S34	FDX10000-ABAAB2012AMAS34
FDBFQ4S44	FDX10000-ABAAB2012AMAS44
FDBHQ7S64	FDX10000-ABAAB5012DMAS44
FD7DFM4S44	FDX1001C-ADAKB2402AMAS44
FFD7DHM7S64	FDX1001C-ADAKB5402DMAS64
FD7NHM7S64	FDX1001C-ANAKB5402DMAS64
FD7DFQ4S44	FDX1001C-ADAAB5012AMAS44
FD7DHQ7S64	FDX1001C-ADAAB5012DMAS44
FD7NHQ7S64	FDX1001C-ANAAB5012DMAS44

TYPICAL WIRING DIAGRAMS

▶ AUTO SUPPLY CASE:
SINGLE FLOAT
DUAL SWITCHES

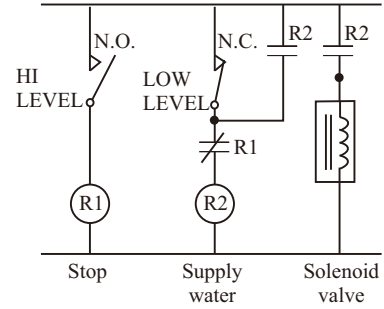
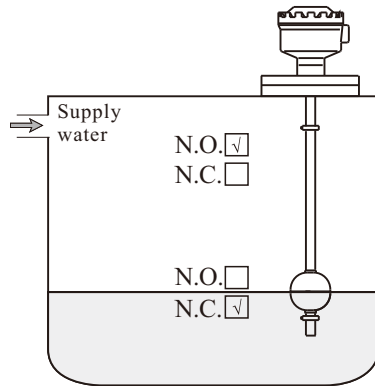

▶ AUTO DRAIN CASE:
SINGLE FLOAT
DUAL SWITCHES

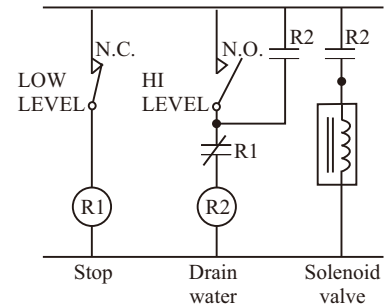
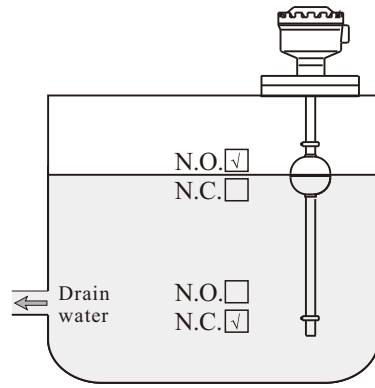

▶ AUTO SUPPLY CASE:
DUAL FLOATS
DUAL SWITCHES

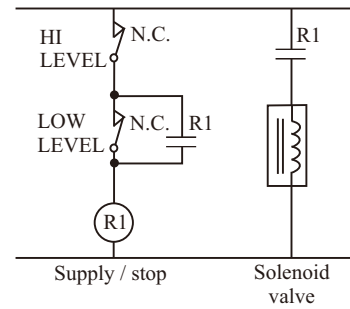
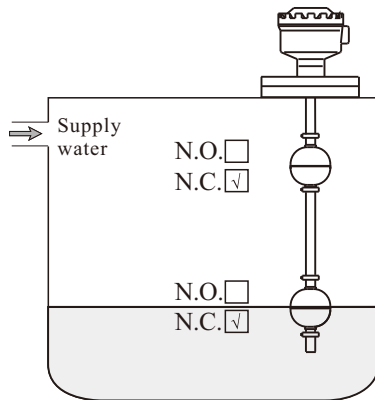

▶ AUTO DRAIN CASE:
DUAL FLOATS
DUAL SWITCHES

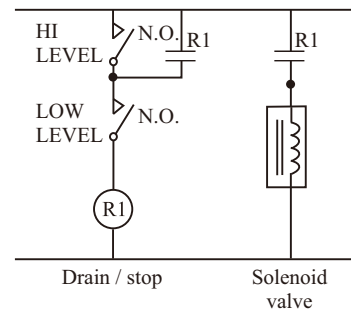
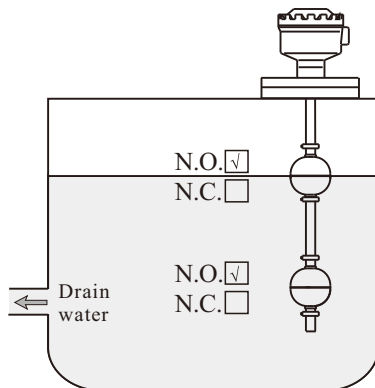

Note: The "N.O." Means normally opened circuit of the reed switch (off) in lower liquid level. As the float moves up to the specified higher level, the circuit closed (on).

The "N.C." Means normally closed circuit of the reed switch (on) in lower liquid level. As the float moves up to the specified higher level, the circuit open (off).

INSTALLATION

- The float level switch should be mounted far away from liquid inlet. Any strong liquid fluctuation will produce error output signals.

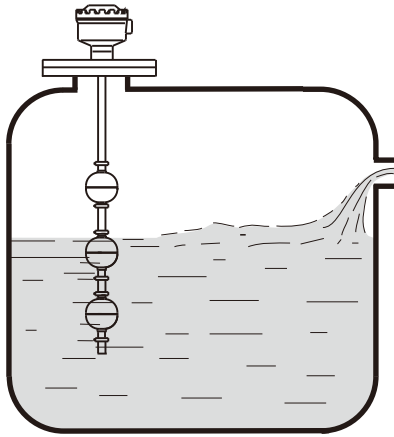

- It is advised to place a pipe shield or equivalent device to normalize the switch actuation if the switch is used near agitator.

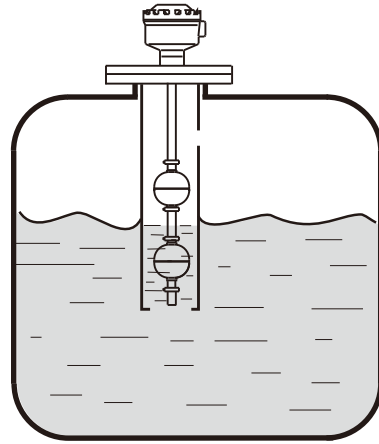

- It had better require an L type supporter, when the switch is mounted in concrete wall tank as figure below.

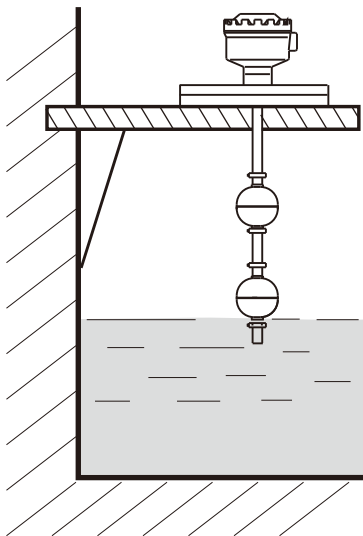

- It is recommended to select the standpipe with diameter larger than the float ball for installation process.

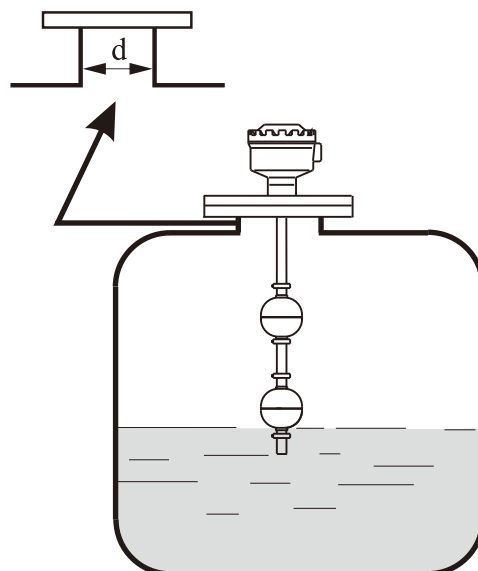

CONNECTION DIAGRAMS

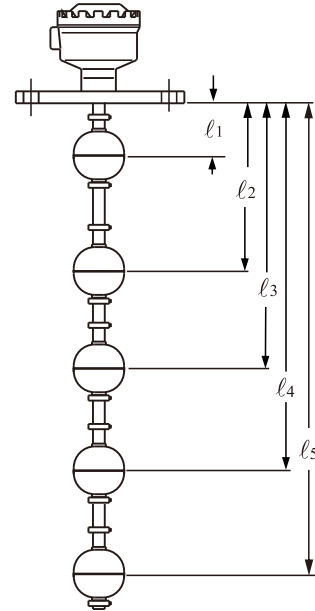
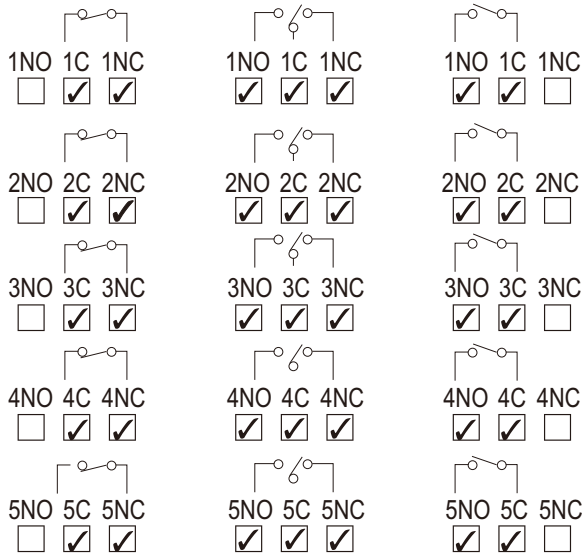

- ※ Means that the NC-C circuit will be close while liquid level lower than the float ball, by mark of NC or B or ↓ ON.
- ※ Means that the NO-C circuit will be close while liquid level higher than the float ball, by mark of NO or A or ↑ ON.
- ※ Means that the NO-C circuit will be close while liquid level higher than the float ball, and NC-C circuit will be close while liquid level lower than the float ball.

※ Please screw the housing cap tightly and fix the conduit outlet, it will reinforce the housing performance against the moisture and direct water. (ϕ 8mm multiple cord is recommended for wiring)

※ If the end user is intended to adjust the actuation level position independently, please move the float ball(s) position as well as the interior reed switches, otherwise, it will appear an error or no signal.

Global Network

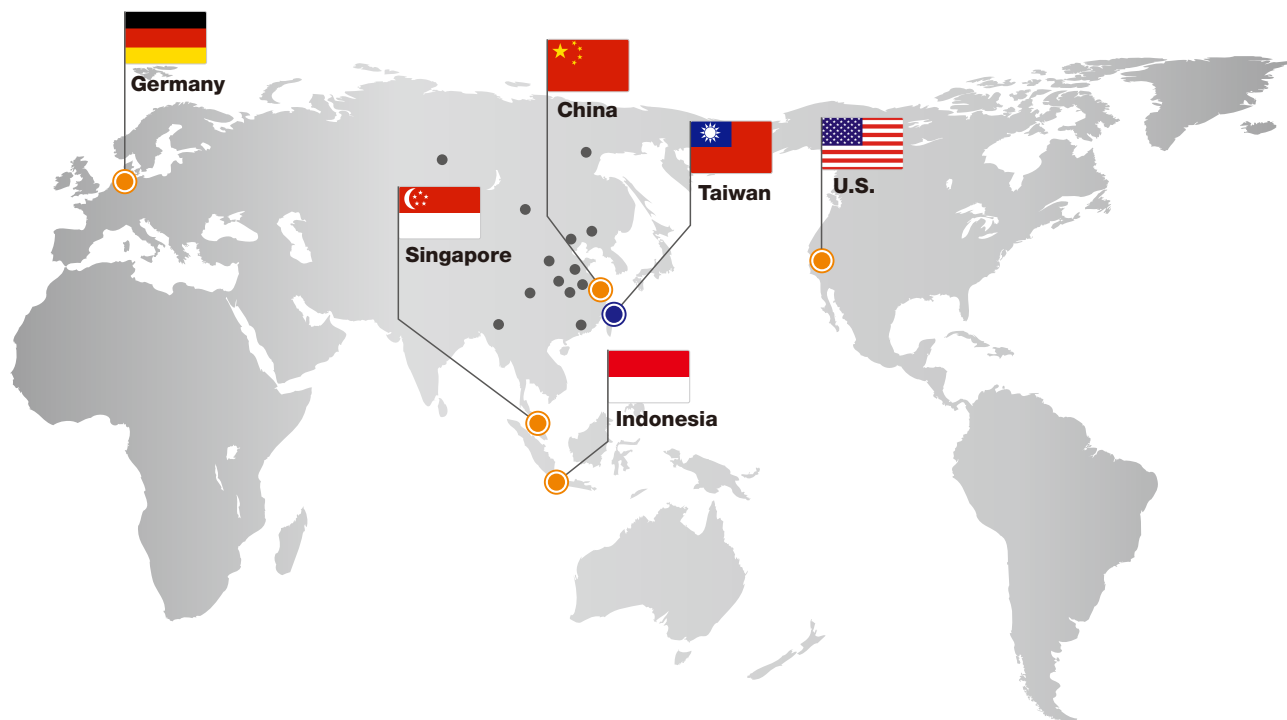

■ Head Quarter

● Taiwan

FineTek Co., Ltd. - Taipei Head Quarter 
 No.16, Tzuchiang St., Tucheng Industrial Park
 New Taipei City 236, Taiwan
 TEL: 886-2-2269-6789
 FAX: 886-2-2268-6682
 EMAIL: info@fine-tek.com

■ North America

● California, U.S.

Aplus Finetek Sensor Inc. - US Office
 355 S. Lemon Ave, Suite D
 Walnut, CA 91789
 TEL: 1 909 598 2488
 FAX: 1 909 598 3188
 EMAIL: info@aplusfine.com

■ Europe

● Germany

FineTek GmbH - Germany Office
 Bei den Kämpen 26
 21220 Seevetal-Ramelsloh, Germany
 TEL: +49-(0)4185-8083-12
 FAX: +49-(0)4185-8083-80
 EMAIL: info@fine-tek.de

■ Asia

● China

Fine automation Co., Ltd. - Shanghai Factory 
 No.451 DuHui Rd, MinHang District, Shanghai,
 China 201109
 TEL: 86-21-6490-7260
 EMAIL: info.sh@fine-tek.com

● Singapore

FineTek Pte Ltd. - Singapore Office
 37 Kaki Bukit Place, Level 4 Singapore 416215
 TEL: 65-6452-6340
 EMAIL: info.sg@fine-tek.com

● Indonesia

PT. FineTek Automation Indonesia - Indonesia Office 
 PERGUDANGAN TUNAS BITUNG
 Jl. Raya Serang KM. 13,8, Blok C3 No. 12&15, Bitung Cikupa,
 Tangerang 15710
 TEL: 62 (021)-2958-1688
 EMAIL: info.id@fine-tek.com

● Mütec Instruments GmbH - Germany Office

Bei den Kämpen 26
 21220 Seevetal-Ramelsloh, Germany
 TEL: +49-(0)4185-8083-0
 FAX: +49-(0)4185-8083-80
 EMAIL: muetec@muetec.de



Distributor: