

Hahn Part Number: 28-222VS
Z 10 28 0350 0 0873 WG35 WG35 00900N /6/Um

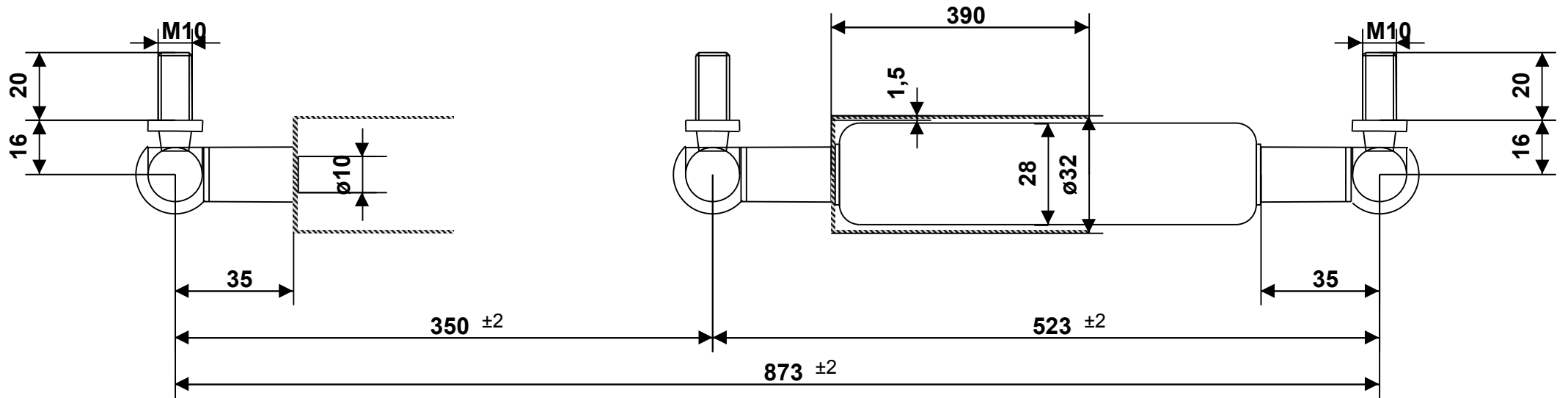

Intended for internal use and customer / Tolerance of ext. length: +/- 2mm - Dimensions without tolerance: per DIN ISO 2768-1 -c (ISO 2768 -c) - For Information Only
 Force tolerance: F1 >= 1000N: +/- 5%; < 1000N: +/- 10%, min.: +/- 10N, max.: +/- 50N - Unregistered Copy, Print-out or file not subject to modification service.
 End fitting orientation is random and not represented by drawing unless specified - Observe disposal instructions - Not true to scale



Please note our technical instructions

Assembly/storing with piston rod up

18. Feb 2025

Auto-Printservice

No opening-no heating-high pressure

Made in Germany

Part

Dimension

Material / Surface

Fitting

Progr.:28,20 %

Drawing owned by Hahn Gasfedern GmbH

Piston rod

Ø10mm

Stahl, hartverchromt

WG35 M10 CS16 GESI

info@hahn-gasfedern.de

Cylinder

Ø28mm

Stahl, verzinkt

WG35 M10 CS16 GESI

www.hahn-gasfedern.de

Configuration ID : 10064764-