

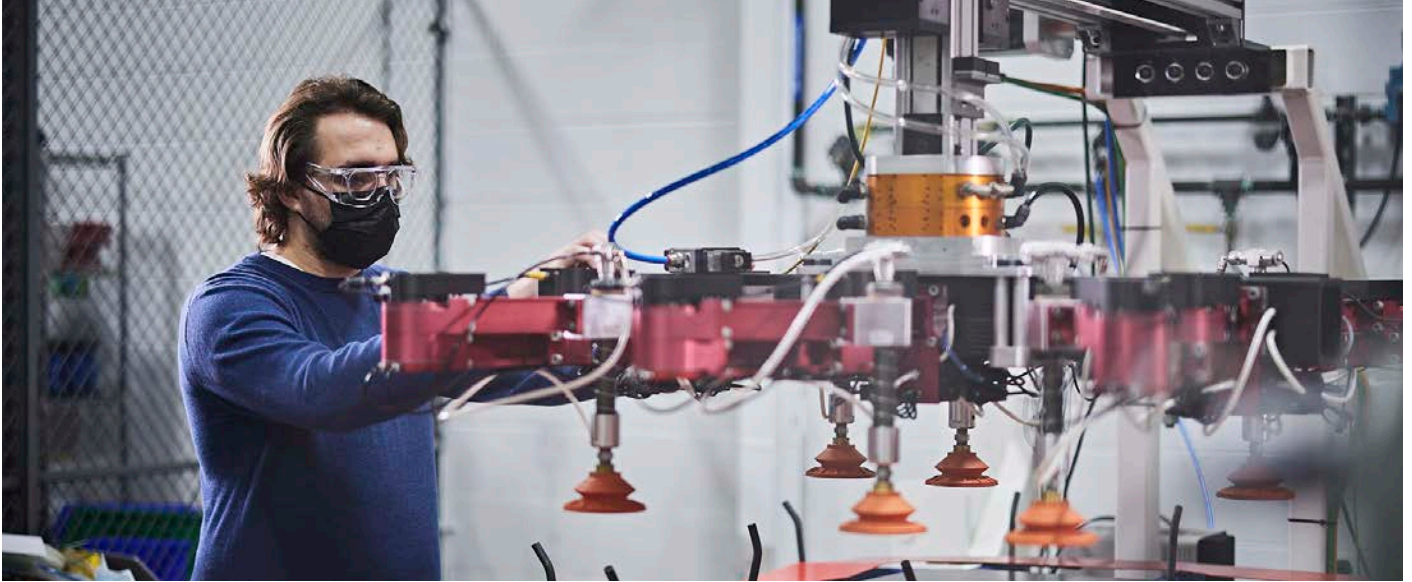

World-class Vacuum Generator Solutions

<https://materialhandling.norgren.com/en>



Breakthrough Engineering for a Better World

Norgren is part of global engineering organisation IMI plc. IMI is at the forefront of delivering the solutions we need in a changing world and is focused on **creating tremendous value by solving key industry problems** in attractive markets and employing the best.

Norgren has a proud history of creating innovative engineering solutions in precise motion control and fluid technology, and we collaborate with our customers across more than 50 countries in critical areas such as Factory Automation, Material Handling, Rail, Energy, Process Control, Life Science and Commercial Vehicles.

From improving speed, productivity, reliability and efficiency of equipment, to generating significant energy and cost savings, or lowering total cost of ownership across many industries, Norgren's high-quality solutions are designed to help customers pursue progress, achieve new goals and overcome problems.

Our world-class portfolio of fluid and motion control products include Norgren, Bimba, Buschjost, FAS, Herion, Kloehn and Maxseal. Supplied either individually or combined into powerful customised solutions to meet customer needs.

With market-leading industry expertise, we offer the capability, resources, engineering intelligence and global support infrastructure to tackle the largest project demands.

Breakthrough engineering you can count on.

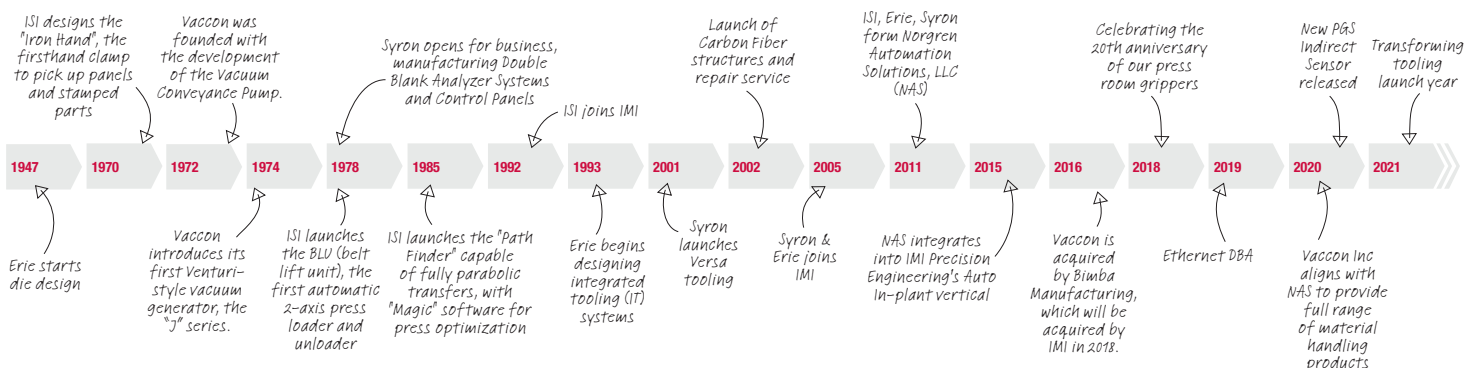

Contents

1		MODULAR VENTURI SINGLE STAGE VACUUM GENERATORS	12	Fast Find Guide
2		CYLINDRICAL VENTURI VACUUM GENERATORS	81	Fast Find Guide
3		VARIABLE VACUUM GENERATORS	102	Fast Find Guide
4		HIGH FLOW VACUUM / BLOWER GENERATORS	110	Fast Find Guide
5		MATERIAL TRANSFER VACUUM GENERATORS	118	Fast Find Guide
6		VACUUM CUPS & FITTINGS	130	Fast Find Guide
7		END-OF-ARM TOOLING	203	Fast Find Guide
8		ACCESSORIES	231	Fast Find Guide



Our Global Reach

With established manufacturing facilities globally, we have the capability to cope with the most demanding of international projects. With a sales and service network in 50 countries, we have the reach and capability to ensure continuity of supply and local support where it is needed.

Global Locations and Partners

Norgren – Material Handling Locations

USA

Norgren Automation Solutions, LLC (NAS)
2871 Bond Street
Rochester Hills, MI 48309 USA

Tel: 1-800-272-4511
Fax: 1-734-429-2981
Email: NASInsideSales@imi-precision.com
Web: www.materialhandling.norgren.com/en

USA

Norgren Automation Solutions, LLC (NAS)
1325 Woodland Drive
Saline, MI 48176 USA

Tel: 1-800-272-4511
Fax: 1-734-429-2981
Email: NASInsideSales@imi-precision.com
Web: www.materialhandling.norgren.com/en

Mexico

Norgren S.A. de C.V.
Av. La Montaña No.120
Parque Industrial Querétaro
Sta. Rosa Jáuregui, Querétaro
Mexico 76220

Tel: +52 442 229 5010
Email: nas.mexico@imi-precision.com

Brazil

IMI Norgren Brazil
Av. Eng. Alberto de Zagottis 696
04675-085 - São Paulo - Brazil

Tel: +55 11 5698 4000
Fax: +55 11 5698 4001
Email: vendas@imi-precision.com

China

Norgren Co., Ltd
埃迈诺冠商贸（上海）有限公司.
Tel: +86 21 24161800
sales@imi-precision.com.cn

India

IMI Norgren Herion Pvt. Ltd.
A-62, Sector 63,
Noida- 201301
Uttar Pradesh
India
Tel: +91 (0) 120 4089500
Fax: +91 (0) 120 4089599
Email: india@imi-precision.com

Spain

IMI Norgren S.A.
Colom, 391, 2º - Edificio Tecno
08223 Terrassa
Tel: +34 937489800
Email: spain@imi-precision.com

Thailand

Norgren Co., Ltd
120/34 M. 12 Rachadhewa, Bangplee
Samutprakarn
10540 Thailand
Tel: +66 (0) 2 2750 3598
Fax: +60 (0) 2 750 3855
Email: THSales@imi-precision.com

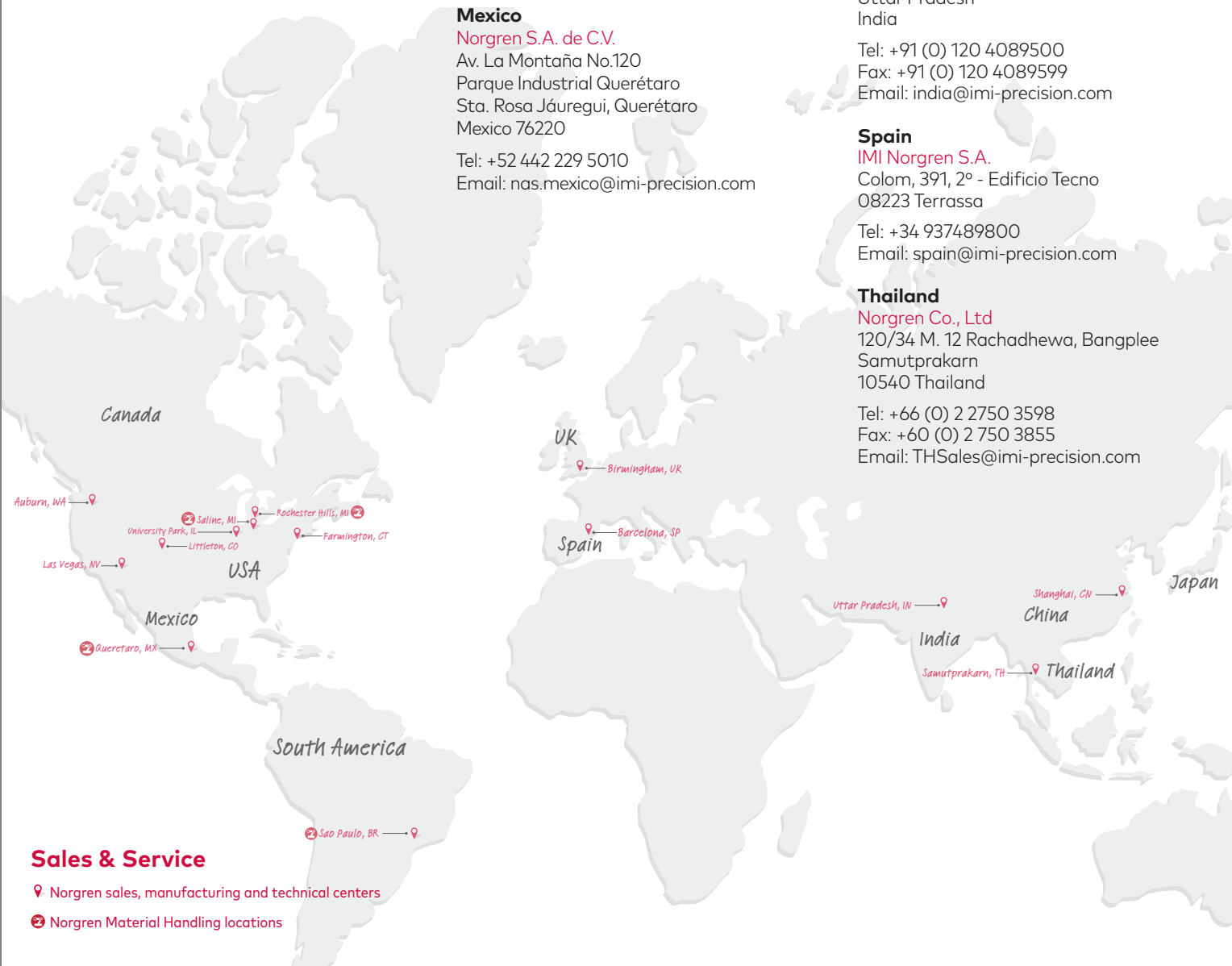

Sales & Service

- 📍 Norgren sales, manufacturing and technical centers
- 🏭 Norgren Material Handling locations



For more information or for additional configurations, please contact us at NASInsideSales@imi-precision.com

PRODUCT SELECTION APPLICATIONS GUIDE



There are hundreds of applications for Norgren products. Often, there is more than one solution for a given application – it all depends on the object being picked up. Contact our vacuum experts to find the best Norgren solution for your application.

Application:	Vacuum Generators and Accessories								
	NJ Series	NVP Series	NMSV Series	NVDF Series	NHVP Series	NCDF Series	NDF Series	EOAT	Vacuum Cups
Air Bearing						•			
Air Blower / Dryer / Cooling						•			
Air Wiper						•	•		
Assembly / Flexible Manufacturing	•	•	•	•		•		•	•
Bag/Box Opening	•	•	•	•		•		•	•
Coating / Spraying				•		•			
Chip Removal						•	•		
Circuit Board Testing	•	•	•					•	•
Cooling of Electronics						•			
Degassing	•	•	•	•	•				
Dirt, Dust & Debris Tolerant	•	•	•	•	•	•	•	•	•
Ejecting Molded Parts	•	•	•				•	•	•
Erecting Corrugated Boxes	•	•	•	•				•	•
Evacuation of Molds	•	•	•	•	•				•
Evaporation Control	•	•	•	•	•	•			
Exhaust / Ventilation				•		•	•		
Food Processing	•	•	•	•		•	•	•	•
Fume / Dust / Chip Removal				•		•	•		
Gas Sampling & Analysis	•	•	•		•				
Inflation / Deflation						•			
Labeling	•	•	•	•				•	•
Leak Detection	•	•	•		•				
Liquid Blending / Mixing	•						•		
Liquids / Creams	•	•	•	•	•				
Loading / Unloading Hoppers							•		
Mandrel Collection						•	•		
Material Transfer:				•			•	•	
Small Parts				•			•	•	
Pellets							•	•	
Powders / Bulk Solids				•			•	•	
Medical / Dental / Lab Suction	•	•	•	•	•				
Packaging	•	•	•	•		•	•	•	•
Palletizing	•	•	•	•				•	•
Paper Feeding / Printing	•	•	•	•		•		•	•
Pick & Place:	•	•	•	•		•		•	•
Corrugated Sheet / Boxes	•	•	•	•				•	•
Electronic Components	•	•	•	•		•			•
Fragile Items	•	•	•	•		•		•	•
Flexible Materials	•	•	•	•		•			•
Glass	•	•	•	•		•		•	•
Metals	•	•	•	•				•	•
Plastics	•	•	•	•		•		•	•
Stone Brick Concrete	•	•	•	•				•	•
Pneumatic Conveying	•	•	•	•		•	•	•	
Powders	•	•	•	•			•		
Sampling	•	•	•	•		•	•		•
Stamping	•	•	•	•	•	•			•
Thermoforming	•	•	•	•		•		•	•
Trim, Selvage & Fiber Collection				•		•	•		
Vacuum Chuck	•	•	•	•					
Vacuum Clamping	•	•	•	•	•				
Vacuum Filling	•	•	•	•			•		
Vacuum Impregnation	•	•	•	•	•				
Vacuum Molding	•	•	•	•	•				
Vacuum Packaging	•	•	•	•		•		•	•
Vacuum Toilets	•	•	•	•					
Veneering	•	•	•	•	•				
Waste & Spill Clean-ups	•	•	•	•			•		
Custom Sizes, Shapes, & Threads	•	•	•	•	•	•	•	•	•
Specialty Materials	•			•		•	•	•	•

HOW VACUUM GENERATORS WORK



To ensure an efficient vacuum system, emphasis should be placed on the vacuum flow path beginning with the object being handled or vessel being evacuated and ending at the vacuum source. Improper sizing of the system components is the most common vacuum system design flaw that we have seen in the field. Vacuum is a low pressure power source (max value of 14.7 PSI, [1 bar]) whose effectiveness is easily reduced by restrictions from tubing, valves, fittings, etc.

An excellent analogy is a person trying to breathe through a cocktail straw. It's almost impossible to survive because the small flow path will not allow enough air to reach your lungs. A drinking straw with its larger flow path let's you breathe much easier by allowing more air flow.

To determine if your system is restricting vacuum flow, place a vacuum gauge at the generator. If the gauge reads vacuum when nothing is connected to the suction cup or a vessel is not attached, the system is restricting flow. If the system is not working, i.e. not picking up a porous object or not evacuating a vessel fast enough, a larger vacuum generator will not fix the system until the flow path size is increased.

In applications where a restriction cannot be eliminated, i.e. when deflating a ball prior to shipping – use a vacuum source that can generate a high vacuum level. Norgren H Series generators provide the fastest evacuation possible.

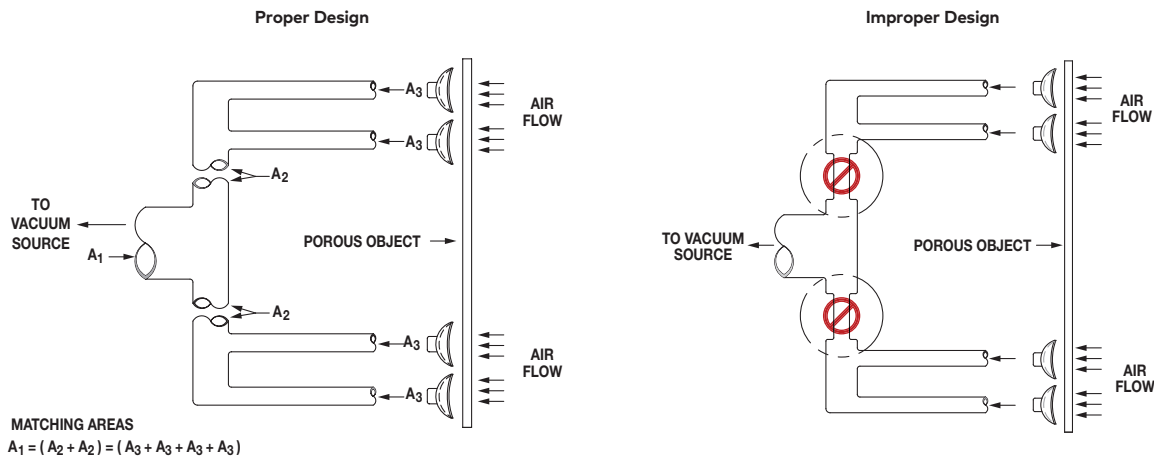

Plumbing a vacuum system is very similar to a municipal water distribution system where the lines closest to the generator are the largest and get smaller as they get to your house (vacuum cup/vessel). The area of each branch of tubing should match that of the next branch and the main trunk line should be sized to handle the maximum flow.

Remember that just a small change in diameter causes a large change in area — a 2x change in diameter increases the area 4x.

VACUUM GENERATOR SELECTION GUIDE



1. Pick and Place/Material Handling:

Pick & Place/Material Handling refers to lifting, gripping, rotating and positioning of an object through the use of a vacuum generator with a vacuum cup.

Use the Equation: Force = Pressure
X Area to determine:

- » Lifting capacity of the generator and cup
- » Required vacuum area, i.e. diameter of the cup – see cup section for a more detailed explanation
- » Required vacuum level of vacuum generator

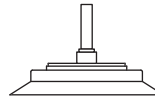
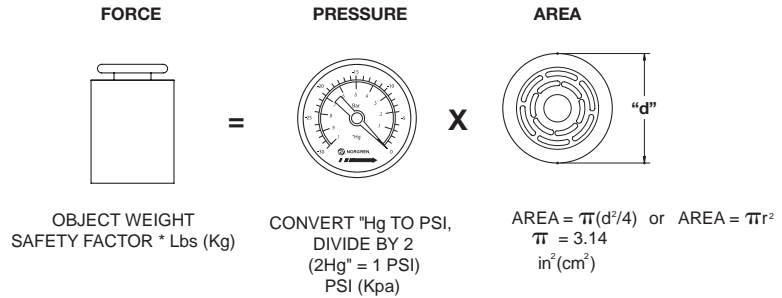

Safety Factors

Horizontal lift = 2
Safety factor of 2
is recommended
when cup face is
in horizontal position.

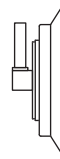

Vertical lift = 4
Safety factor of 4
is recommended
when cup face is
in vertical position.

Force = Pressure x Area where:

F = the weight of the objects in lbs [kg] multiplied by the safety factor above

P = the expected vacuum level in PSI [Kpa], remember to convert "Hg to PSI by dividing by 2

A = the area of the Vacuum Cup measured in square inches. Use the equation $A = \frac{\pi d^2}{4}$

3 Vacuum Level Ranges:

- > "L", "X" or "F" Series 0-10"Hg, [0 to 339mbar] for high efficiency applications
- > "M", "Y" or "D" Series 0-20"Hg, [0 to 677mbar] for low operating pressure applications
- > "H", "Z" or "S" Series 0-28"Hg, [0 to 948mbar] for high flow applications

3 Types of Material:

- > Non-porous materials: steel, glass laminated chipboard, rigid plastic, semiconductors, etc.
- > Porous materials: corrugated, wood, foam, felt, woven materials, objects with extremely rough or uneven surfaces
- > Flexible materials: plastic films, baked good, IV bags, paper bags – things that wrinkle

Inexact Science:

When handling porous materials such as corrugated or heavy fabric, it may be hard to choose the exact generator required because the leakage rate is not normally known. It is best to run a trial to test the ability of the generator to overcome the leakage. For existing systems, consult Norgren for the equivalent generator size.

System Speed:

Cycle rate of the generator/cup system is determined by the evacuation speed of the venturi.
See Vessel Evacuation.

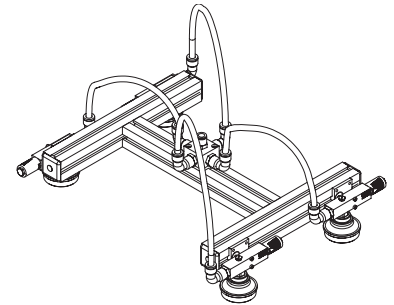

Increase safety, reliability and speed by using one generator and one cup at each location. Should one cup fail the others will maintain their grip.



2. Vessel Evacuation:

In many process applications it is necessary to evacuate a vessel for the purpose of purging gases, leak testing and degassing viscous fluids. It may also be simply the length of tubing between the generator and cup that needs to be evacuated.

Knowing the generator's evacuation speed will help determine process completion time or the production rate of a pick & place system. To find the speed, use the evacuation charts listed in the performance data for each venturi generator. Note that the charts are based on a volume of one cubic foot or one liter of volume to a given vacuum level in "Hg or mbar.

1. Determine the total volume to be evacuated – vessel and/or vacuum lines (cu. ft.), 1728 cu. in = 1 cu. ft.
2. Desired vacuum level Hg [mbar] is determined by customer
3. Time to reach vacuum level (seconds) – determined by customer

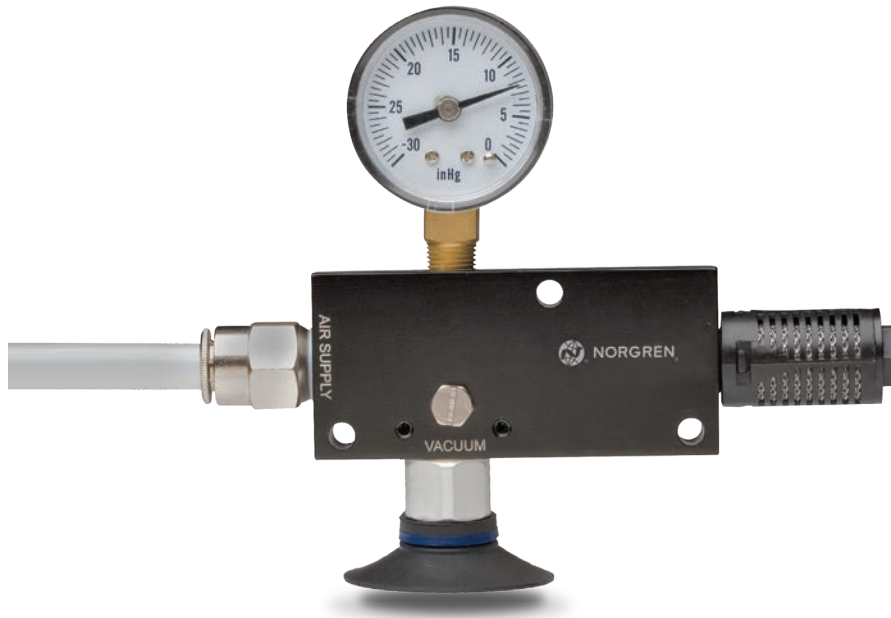



Application #1

Evacuate Vacuum Lines Between Vacuum Cup and Generator

Application #1 Assumptions:

Desired Vacuum level: 28"Hg [948 mbar]
 Evacuation time: 10 seconds or less
 Vacuum line: 3/8" ID, 3 ft length [10mm ID, 100cm length]

- Volume = Area of Tubing ID x Length

$$\frac{\pi d^2}{4} \times L = \frac{\pi (.375)^2}{4} \times 36" = 3.976 \text{ cu. in.}$$

$$\left[\frac{\pi d^2}{4} \times L = \frac{\pi (1\text{cm})^2}{4} \times 100\text{cm} = 78 \text{ cm}^3 \right]$$
- Convert cu. in. to cu. ft – divide by 1728
3.976 / 1728 = 0.0023 cu. ft. (volume of tubing)
 [Convert cu. cm to liters - divide by 1000
78 / 1000 = 0.078 liters (volume of tubing)]
- Go to Evacuation Time chart – find desired vacuum level.
28"Hg = 790.80 seconds per cu. ft.
[948 mbar = 27.9 seconds per liter]
- Multiply cu. ft **(0.0023 x 790.80) = 1.82 seconds**
 [Multiply liters **(0.078 x 27.9) = 2.17 seconds]**

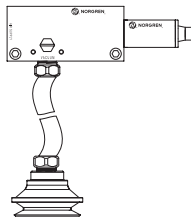

Answer:

Depending on the style of generator and options needed, choose from either the NVP Series or NJ Series generators – both series have the ability to meet your application requirements.

Application #2

Evacuate Vessel and Vacuum Lines Find Total System Volume

Application #2 Assumptions:

Desired Vacuum level: 28"Hg [948 mbar]
 Evacuation time: 5 minutes or less
 Vessel volume: 2 cu ft [50 liters]
 Vacuum line: 3/8" ID, 3 ft length [10mm ID, 100cm length]

- Add vessel volume + tubing volume (See Application 1.1 & 1.2)
2 cu. ft + 0.0023 cu. ft. = 2.0023 cu ft.
[50 liters + 0.078 liters = 50.078 liters]
- Go to Evacuation Time chart – find desired vacuum level.
 (Assumption: 28"Hg [948 mbar]) (Note: Chart is based on Evacuation in seconds.)
- To find required time, start with smallest generator first.
 (Assumption: Evacuation Time - 5 minutes or less.)

 Multiply cu. ft. [liters] x Evacuation Time in Seconds / divide by 60 for minutes
 Model # 60H = (2.0023 x 790.8) / 60 = 26.39 min. - over 5 minutes
 (Metric) = (50.078 x 27.9) / 60 = 23.29 min. - over 5 minutes
Model # 150H = (2.0023 x 125) / 60 = 4.17 min - under 5 minutes
(Metric) = (50.078 x 4.4) / 60 = 3.67 minutes - under 5 minutes

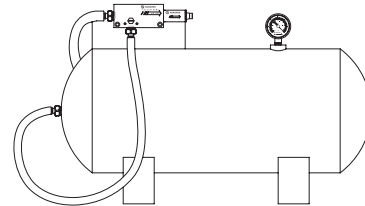

Answer:

Depending on the style of generator and options needed, choose from either the NVP Series or NJ Series generators – both series have the ability to meet your application requirements.

Model #	Evacuation Time in Seconds Based on 1 Cu. Ft. Volume /"Hg										
	0"Hg	3"Hg	6"Hg	9"Hg	12"Hg	15"Hg	18"Hg	21"Hg	24"Hg	27"Hg	28"Hg
N60H	0.00	15.00	29.80	50.60	74.20	102.80	135.90	183.20	245.90	410.20	790.80
N150H	0.00	2.30	3.80	6.50	10.20	14.10	21.30	44.90	55.00	81.00	125.00

Model #	Evacuation Time in Seconds Based on 1 Liter Volume/mbar										
	(0 mbar)	(102 mbar)	(203 mbar)	(305 mbar)	(406 mbar)	(508 mbar)	(609 mbar)	(711 mbar)	(813 mbar)	(914 mbar)	(948 mbar)
N60H	(0.0)	(0.5)	(1.1)	(1.8)	(2.6)	(3.6)	(4.8)	(6.5)	(8.7)	(14.5)	(27.9)
N150H	(0.0)	(0.1)	(0.1)	(0.2)	(0.4)	(0.5)	(0.8)	(1.6)	(1.9)	(2.9)	(4.4)

VACUUM TERMS AND DEFINITIONS



Air Consumption:

The volume of compressed air required to power the generator.

Atmospheric Pressure:

The atmosphere that surrounds the Earth can be considered a reservoir of low pressure air. Its weight exerts a pressure that varies with temperature, humidity and altitude.

Barometer:

A device usually filled with mercury that measures atmospheric pressure.

Compressed Air Considerations:

1HP @ 80 PSI generates approximately 4 SCFM of flow.

Standard or Average Atmospheric Pressure at Sea Level:

29.92"Hg or [760 mmHg]

Vacuum Flow:

The volume of free air induced by the vacuum generator per unit of time, expressed as standard cubic feet per minute – SCFM or [liters per minute - LPM]

Vacuum Force:

Equal to the vacuum level X the area of the vacuum surface, i.e. holding area of a vacuum cup.

Vacuum Level/Elevation:

The magnitude of the suction created by the vacuum generator. The unit of measure is inches of Hg ("Hg) or (mbar). Vacuum level is affected by elevation and barometric pressure. For each 1,000 feet of elevation, vacuum level decreases by 1" of Hg.

Venturi's, Ejectors, Transducers, Generators, Eductors:

All of these are different names for air powered vacuum generators.

Facts to Remember:

50 mmHg = 1 PSI
 1mmHg = 1 torr (vacuum)
 1"Hg = 25.4 mmHg
 2"Hg = 1 PSI
 29.92"Hg = 100 Kpa
 14.7 PSI = 100 Kpa
 14.7 PSI = 29.92"Hg
 14.7 PSI = 760 mmHg

Conversion Chart – Vacuum vs. Pressure

% Vacuum	"Hg	mmHg	bar	PSI
10	3	76.92	-0.1	-1.47
20	6	153.85	-0.2	-2.94
30	9	230.77	-0.3	-4.41
40	12	307.69	-0.4	-5.88
50	15	384.62	-0.5	-7.35
60	18	461.54	-0.6	-8.82
70	21	538.46	-0.7	-10.29
80	24	615.38	-0.8	-11.76
90	27	692.31	-0.9	-13.23
100	30	769.23	-1.0	-14.70

Vacuum vs. Elevation: Vacuum Level = The magnitude of suction created by the vacuum generator. Vacuum level is affected by elevation and barometric pressure. For each 1,000 feet of elevation, the vacuum level that the generator can achieve decreases by approximately 1"Hg [33.9mbar].

ISO 9001:2008 Certified • Made in the USA



Questions to ask when sizing a vacuum system

Vacuum technology is the quickest, safest and most efficient method of moving products from point A to B. When designing a system, knowing the size, weight, porosity, texture and other physical features of the product is critical to selecting the right generator/cup combination to meet your cycle times, performance requirements or evacuation speeds. Below is a simple checklist to help you gather the pertinent information to begin the design process.

- Weight? _____
- What is the material to be held, lifted, rotated, etc.? _____
- Overall Dimensions? _____
- Surface Conditions (Rough, Smooth, Curved)? _____
- Temperature of Product? _____
- Porosity (Example: Corrugated cardboard vs. Steel, Glass)? _____
- Available surface to grip with vacuum cups or other device? _____
- Overall Cycle Time? _____
- Percent of cycle that vacuum is used? _____
- How is vacuum released (Compressed air through an air valve, or vented)? _____
- What size vacuum line (Inside diameter & length)? _____
- Is a surge tank used to store vacuum? _____
- What pressure is available (80 PSI, 5.5 bar, etc.)? _____
- What vacuum level is desired? _____

If an existing application:

- What vacuum level is being achieved? _____
- What is being used now to generate vacuum (electric or air powered generator)? _____
- Customer complaints? (Expensive, noisy, high temperature, maintenance, etc.)? _____
- Model Number of existing generator? _____
- If suction cups are used, what size (Outside Diameter)? _____
- What style of suction cup (Flat, Bellows, Oval, Cleated, etc.)? _____
- How many suction cups are connected to one generator? _____
- What vacuum level is necessary to perform the task? _____
- Is there physical space to run one generator per suction cup? _____

Modular Venturi Vacuum Generators



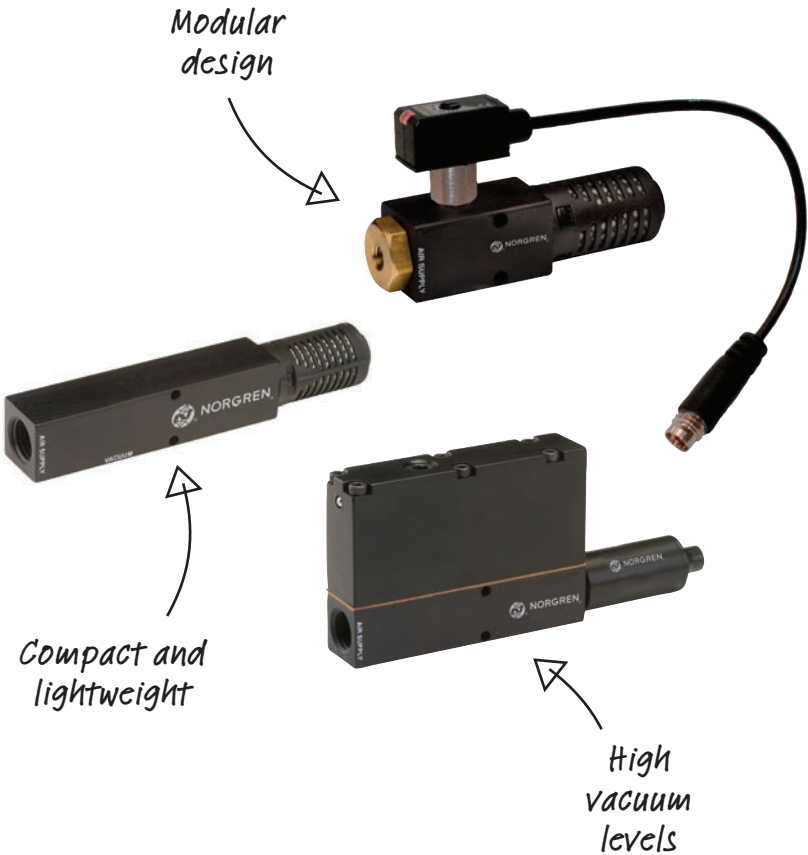



The NVP Series provides maximum design flexibility by using a modular component approach. Integrating a venturi vacuum generator, sensors, and switches within one assembly, the NVP Series provides complete vacuum systems capable of interfacing with control systems.



Fast Find Guide

Please note: These products represent only part of the Norgren vacuum range. If you can't see the option you require please contact us.

Modular Venturi Vacuum Generators

<p>NVP00 Min Series - Vacuum level up to 28"Hg, flow up to 0.50 SCFM, compact / lightweight with blowoff option</p>  <p>Page 14</p>	<p>NVP10 Mid Series - Vacuum level up to 28"Hg, flow up to 3.20 SCFM, with blowoff, multi-port options</p>  <p>Page 21</p>	<p>NVP20 Mid Series - Vacuum level up to 28"Hg, flow up to 3.20 SCFM, with blowoff, multi-port, air saver options</p>  <p>Page 29</p>	<p>NVP50 Mid Series - Vacuum level up to 28"Hg, flow up to 3.20 SCFM, with blowoff, air saver options</p>  <p>Page 43</p>	<p>NVP80 Max Series Vacuum level up to 28"Hg, flow up to 9.00 SCFM</p>  <p>Page 48</p>
<p>NVP90 Max Series Vacuum level up to 28"Hg, flow up to 28.00 SCFM</p>  <p>Page 66</p>	<p>NHVP High Vac Series Vacuum level up to 29.5"Hg, flow up to 6.00 SCFM</p>  <p>Page 79</p>			



- » High Productivity – non-clogging design reduces downtime
- » Strong hold – powerful vacuum up to 28"Hg [948mbar]
- » Mounts Easily – compact and lightweight
- » Fast Response – installs close to vacuum point
- » Efficient – minimal air consumption
- » Reliable operation – straight-through design with no moving parts

Technical Data

Fluid

Filtered (50 Micron) unlubricated, non-corrosive dry gases

Operating Pressure

80 PSI (5.5 bar) Standard or 60 PSI (4.1 bar)

Operating Temperature

-30° to -250° F (-34° to 121°C)

Materials

Generator Body: Anodized Aluminum

Supply line

Min. 5/32" (4mm)

Vacuum line

1/4" (6mm)

Mounting holes

Mounting holes accept 4-40 [M3] screws

Control valve

3 way/2 position (faster part release), minimum orifice – 0.062" [1.57mm]

Performance level designations

"M", "Y" 0-20"Hg [0 to 677mbar] for medium vacuum/high flow applications "H", "Z" 0-28"Hg [0 to 948mbar] for high vacuum/standard flow applications

Product options

Standard (NVP00)

Pneumatic blow-off (NVPOX)

Valve Controlled blow-off (NVP01)



Standard Models

Part number	Max. Vacuum Level	Max. Vacuum Flow	Air Consumption	Silencer
NVP00-60M-S04A00	20"Hg	0.5 SCFM	0.5 SCFM	NST2 Silencer
NVP00-60H-S04A00	28"Hg	0.5 SCFM	0.8 SCFM	NST2 Silencer

Accessories

Option selector

Series	Substitute	NVP 00-60 -S A		Accessories	Substitute
NVP (Imperial Thread)				Extra Ports / No Accessories (standard)	A00
NVPM (Metric Thread)	M			Extra Ports / NVTMV-QD-6	A02
Vacuum Flow Level	Substitute			Extra Ports / NVSMN-QD-6	A04
20"Hg @ 80PSI (Standard)	M			Extra Ports / NVSMP-QD-6	A06
28"Hg @ 80PSI (Standard)	H			No Part / No Accessories	A99
20"Hg @ 60PSI	Y			Silencers	Substitute
28"Hg @ 60PSI	Z			None	S00
				NAA2 (58dB)	S01
				NST2 (68dB)	S04

Accessories

Standard Models	Inline Fitting	Elbow Fitting	Vacuum Fitting	Bellows Cup	Flat Cup	Spring Leveler
NVP00-60M-S04A00	124250210	124470210	NVCF13-1032M	NBG*****	NFG*****	NVSL1_***
NVP00-60H-S04A00	124250210	124470210	NVCF13-1032M	NBG*****	NFG*****	NVSL1_***

*Proper selection of vacuum cups depends on the application. Cups are available in various durometers, colors and materials. If you do not see what you are looking for, please consult factory
 *The fittings, cups, and spring levelers listed are a small selection of possible options please refer to the specific catalog section

Dimensions inches (mm)

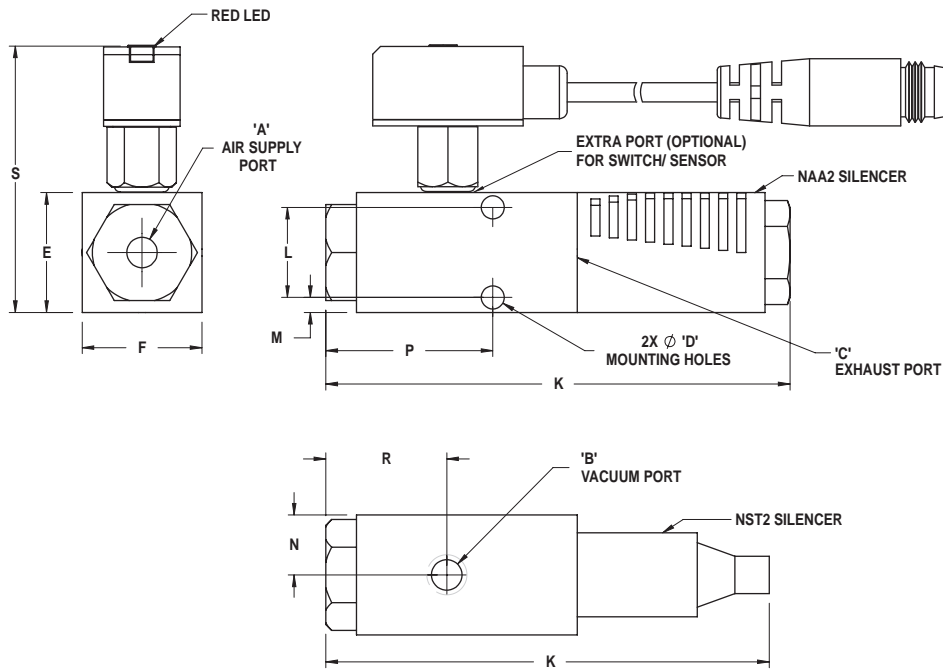

Model	Units	A	B	C	D	E	F	K	L	M	N	P	R	S
NVP00-60*-S01A0*	Imperial	10-32	10-32	1/8 NPTF	0.12	0.62	0.62	2.42	0.47	0.08	0.31	0.89	0.63	1.36
NVP00-60*-S04A0*	Imperial	10-32	10-32	1/8 NPTF	0.12	0.62	0.62	2.35	0.47	0.08	0.31	0.89	0.63	1.36
NVPM00-60*-S01A0*	(Metric)	(M5)	(M5)	(G 1/8)	(3.0)	(15.8)	(15.8)	(61.5)	(11.9)	(2.0)	(7.9)	(22.6)	(16.0)	(34.5)
NVPM00-60*-S04A0*	(Metric)	(M5)	(M5)	(G 1/8)	(3.0)	(15.8)	(15.8)	(59.7)	(11.9)	(2.0)	(7.9)	(22.6)	(16.0)	(34.5)

NVPOX

PNEUMATIC BLOW-OFF



- » All in one vacuum and blow-off - only compressed air required
- » High Productivity - non-clogging design reduces downtime
- » Strong hold - powerful vacuum up to 28"Hg [948mbar]
- » Mounts Easily - compact and lightweight
- » Fast Response - installs close to vacuum point
- » Efficient - minimal air consumption
- » Reliable operation - straight-through design with no moving parts

Technical Data

Fluid

Filtered (50 Micron) unlubricated, non-corrosive dry gases

Operating Pressure

80 PSI (5.5 bar) Standard or 60 PSI (4.1 bar)

Operating temperature

+32° to -125° F [0° to -52°C]

Materials

Generator Body: Anodized Aluminum

Generator options

B1 adjustable version allows the user to set the intensity of the blow-off from no blow-off to full blow-off

Cycle rates

Up to 900/min

Blow-off response time

Instantaneous

Blow-off Duration

100 milliseconds (based on system design)

Orientation

Any

Supply line

Min. 5/32" (4mm)

Vacuum line

1/4" (6mm)

Mounting holes

Mounting holes accept 4-40 [M3] screws

Control valve

3 way/2 position (faster part release), minimum orifice - 0.093" [2.5mm]

Performance level designations

"M", "Y" 0-20"Hg [0 to 677mbar] for medium vacuum/high flow applications "H", "Z" 0-28"Hg [0 to 948mbar] for high vacuum/standard flow applications

Product options

Standard (NVPO0)

Pneumatic blow-off (NVPOX)

Valve Controlled blow-off

(NVPO1)



Standard Models

Part number	Max. Vacuum Level	Max. Vacuum Flow	Air Consumption	Silencer
NVPOX-60M-S04A00	20"Hg	0.5 SCFM	0.5 SCFM	NST2 Silencer
NVPOX-60H-S04A00	28"Hg	0.5 SCFM	0.8 SCFM	NST2 Silencer

Accessories

Option selector

Series	Substitute	NVP OX -60 -S A	Accessories	Substitute
NVP (Imperial Thread)			Extra Port if Available / No Accessories (standard)	A00
NVPM (Metric Thread)	M		Extra Port if Available / NVTMV-QD-6	A02
Blowoff	Substitute		Extra Port if Available / NVSMN-QD-6	A04
Non-adjustable (Standard)	BO		Extra Port if Available / NVSMN-QD-6	A04
Adjustable	B1		No Extra Port / No Accessories	A99
Vacuum Level	Substitute		Silencers	Substitute
20"Hg @ 80PSI (Standard)	M		None	S00
28"Hg @ 80PSI (Standard)	H		NAA2 (58dB)	S01
20"Hg @ 60PSI	Y		NST2 (68dB)	S04
28"Hg @ 60PSI	Z			

NVPOX

PNEUMATIC BLOW-OFF



Dimensions inches (mm)

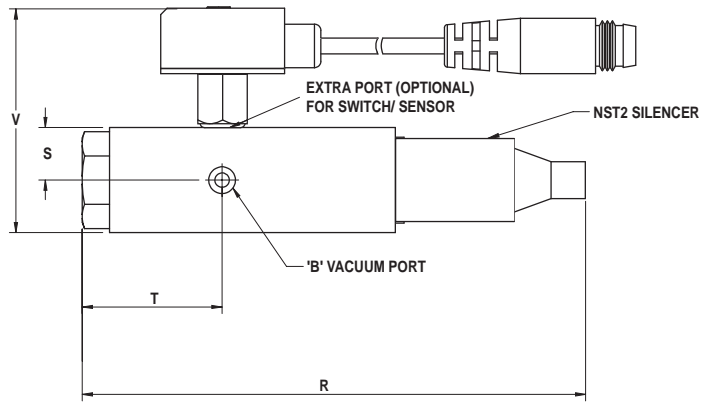
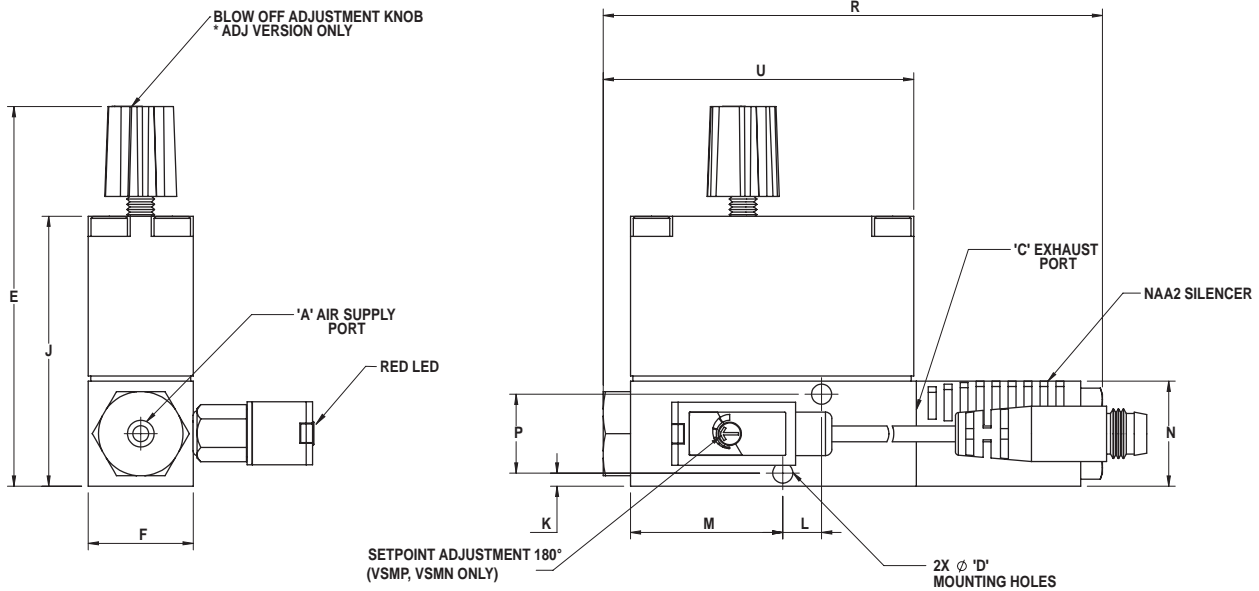

Model	Units	A	B	C	D	E*	F	J	K	L	M	N	P	R	S	T	U	V
NVPOXB0-60*-S01A0*	Imperial	10-32	10-32	1/8 NPTF	0.12	2.26	0.63	1.61	0.078	0.23	0.91	0.63	0.47	2.97	0.31	0.83	1.85	1.36
NVPOXB0-60*-S04A0*	Imperial	10-32	10-32	1/8 NPTF	0.12	2.26	0.63	1.61	0.078	0.23	0.91	0.63	0.47	2.90	0.31	0.83	1.85	1.36
NVPMOXB0-60*-S01A0*	(Metric)	(M5)	(M5)	(G 1/8)	(3.0)	(57.4)	(16.0)	(40.9)	(2.0)	(5.8)	(23.1)	(15.9)	(11.9)	(75.4)	(7.9)	(21.1)	(47.0)	(34.5)
NVPMOXB0-60*-S04A0*	(Metric)	(M5)	(M5)	(G 1/8)	(3.0)	(57.4)	(16.0)	(40.9)	(2.0)	(5.8)	(23.1)	(15.9)	(11.9)	(73.7)	(7.9)	(21.1)	(47.0)	(34.5)



- » High Productivity – non-clogging design reduces downtime
- » Strong hold – powerful vacuum up to 28"Hg [948mbar]
- » Mounts Easily – compact and lightweight
- » Fast Response – installs close to vacuum point
- » Efficient – minimal air consumption
- » Reliable operation – straight-through design with no moving parts

Technical Data

Fluid

Filtered (50 Micron)
unlubricated, non-corrosive dry gases

Operating Pressure

80 PSI (5.5 bar) Standard or
60 PSI (4.1 bar)

Operating Temperature

-30° to -250° F (-34° to 121°C)
20° to 120°F [-7° to 49°C]
(Valve option)

Materials

Generator Body: Anodized
Aluminum

Supply line

Min. 5/32" (4mm)

Vacuum line

1/4" (6mm)

Mounting holes

Mounting holes accept 4-40 [M3]
screws

Electrical

24V -5% to 10% (VA/VD, VB/VE
option)

12V -5% to 10% (VC/VF option)

Power Consumption (Watts)

1.6 watts

Response Times

8 milliseconds

Cycle Rate

45 cycles/second

Average Valve Life

50 million cycles

Electrical Connection

11.8" Flying Lead

LED Indicator with Manual Override

Yes

Control valve

12V (VC/VF option) or 24V
normally closed (VA/VD option)
or 24V normally open
(VB/VE option)

Performance level designations

"M", "Y" 0-20"Hg [0 to 677mbar]
for medium vacuum/high flow
applications "H", "Z" 0-28"Hg
[0 to 948mbar] for high vacuum/
standard flow applications

Product options

Standard (NVP00)
Pneumatic blow-off (NVPOX)
Valve Controlled blow-off
(NVP01)

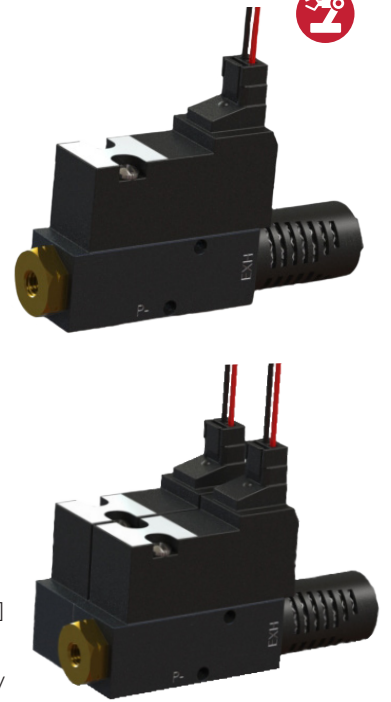

Standard Models

Part number	Valve	Max. Vacuum Level	Max. Vacuum Flow	Air Consumption	Silencer	Blow Off
NVP01VA-60M-S04A00	NC 24V	20"Hg	0.5 SCFM	0.5 SCFM	NST2 Silencer	None
NVP01VA-60H-S04A00	NC 24V	28"Hg	0.5 SCFM	0.8 SCFM	NST2 Silencer	None
NVP01VD-60M-S04A00	NC 24V	20"Hg	0.5 SCFM	0.5 SCFM	NST2 Silencer	Valve Controlled
NVP01VD-60H-S04A00	NC 24V	28"Hg	0.5 SCFM	0.8 SCFM	NST2 Silencer	Valve Controlled

Accessories

Option selector

Series	Substitute	Accessories	Substitute
NVP (Imperial Thread)		Extra Ports / No Accessories (standard)	A00
NVPM (Metric Thread)	M	Extra Ports / NVTMV-QD-6	A02
Valve	Substitute	Extra Ports / NVSMN-QD-6	A04
NC 24V Vacuum	VA	Extra Ports / NVSMP-QD-6	A06
NO 24V Vacuum	VB	No Part / No Accessories	A99
NC 12V Vacuum	VC	Silencers	Substitute
NC 24V Vacuum, NC 24V Blow Off	VD	None	S00
NO 24V Vacuum, NC 24V Blow Off	VE	NAA2 (58dB)	S01
NC 12V Vacuum, NC 12V Blow Off	VF	NST2 (68dB)	S04
Vacuum Flow Level	Substitute		
20"Hg @ 80PSI (Standard)	M		
28"Hg @ 80PSI (Standard)	H		
20"Hg @ 60PSI	Y		
28"Hg @ 60PSI	Z		

NVP 01 -60 -S A

Accessories

Standard Models	Inline Fitting	Elbow Fitting	Vacuum Fitting	Bellows Cup	Flat Cup	Spring Leveler
NVP01VA-60M-S04A00	124250210	124470210	NVCF13-1032M	NBG*****	NFG*****	NVSL1_***
NVP01VA-60H-S04A00	124250210	124470210	NVCF13-1032M	NBG*****	NFG*****	NVSL1_***

*Proper selection of vacuum cups depends on the application. Cups are available in various durometers, colors and materials. If you do not see what you are looking for, please consult factory
 *The fittings, cups, and spring levelers listed are a small selection of possible options please refer to the specific catalog section

Dimensions inches (mm)

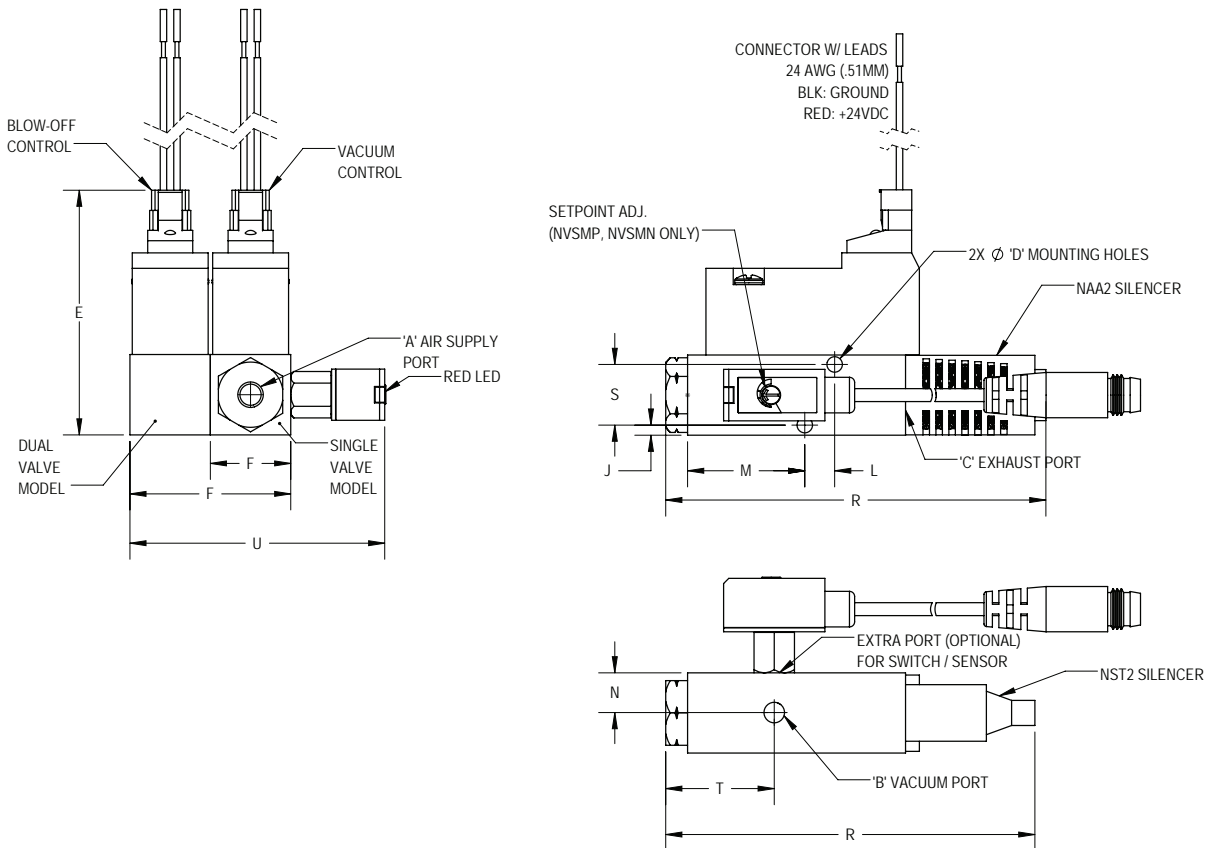

Model	Units	A	B	C	D	E	F	J	L	M	N	R	S	T	U
NVP01VA-60*-S01A0*	Imperial	10-32	10-32	1/8 NPTF	0.12	1.90	0.63	0.08	0.23	0.91	0.31	2.94	0.47	0.84	1.35
NVP01VA-60*-S04A0*	Imperial	10-32	10-32	1/8 NPTF	0.12	1.90	0.63	0.08	0.23	0.91	0.31	2.85	0.47	0.84	1.35
NVPM01VA-60*-S01A0*	(Metric)	(M5)	(M5)	(G 1/8)	(3.0)	(48.3)	(16.0)	(2.0)	(5.8)	(23.1)	(7.9)	(74.7)	(11.9)	(21.3)	(34.3)
NVPM01VA-60*-S04A0*	(Metric)	(M5)	(M5)	(G 1/8)	(3.0)	(48.3)	(16.0)	(2.0)	(5.8)	(23.1)	(7.9)	(72.4)	(11.9)	(21.3)	(34.3)
NVP01VD-60*-S01A0*	Imperial	10-32	10-32	1/8 NPTF	0.12	1.90	1.25	0.08	0.23	0.91	0.31	2.94	0.47	0.84	1.98
NVPM01VD-60*-S01A0*	(Metric)	(M5)	(M5)	(G 1/8)	(3.0)	(48.3)	(31.8)	(2.0)	(5.8)	(23.1)	(7.9)	(74.7)	(11.9)	(21.3)	(50.3)



Performance Data

Model	Air Consumption SCFM (L/min)	Vacuum Level "Hg (mbar)	0"Hg (0)	3"Hg (102)	6"Hg (203)	9"Hg (305)	12"Hg (406)	15"Hg (508)	18"Hg (609)	20"Hg (677)	21"Hg (711)	24"Hg (813)	27"Hg (914)	28"Hg (948)	
60M	0.50 (14.2)	Vacuum Flow	0.50	0.40	0.30	0.22	0.15	0.08	0.03	0.00	-	-	-	-	
		SCFM (L/min)	(14.2)	(11.3)	(8.5)	(6.2)	(4.2)	(2.3)	(0.8)	(0.0)	(-)	(-)	(-)	(-)	
		Evacuation time (seconds)	0.00	12.50	25.10	43.90	68.60	99.30	153.70	227.00	-	-	-	-	
60H	0.80 (22.7)	Vacuum Flow	0.50	0.38	0.32	0.30	0.27	0.23	0.20	-	0.13	0.05	0.02	0.00	
		SCFM (L/min)	(14.2)	(10.8)	(9.1)	(8.5)	(7.6)	(6.5)	(5.7)	(5.4)	(-)	(3.7)	(1.4)	(0.6)	(0.0)
		Evacuation time (seconds)	0.00	15.00	29.80	50.60	74.50	102.80	135.90	-	182.20	245.90	410.20	790.80	

Evacuation time in seconds based on 1 cubic foot volume / "Hg (1 Liter Volume / mbar)

MODULAR VACUUM GENERATORS

**Air Consumption vs Supply Pressure
Mini Series - "M" Models**

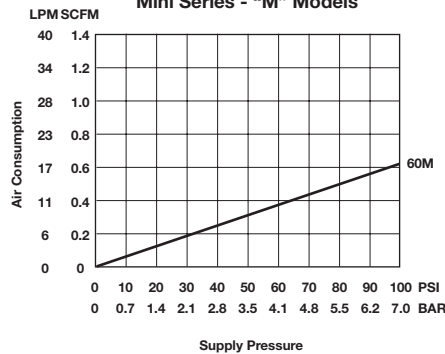

**Vacuum Flow vs Supply Pressure
Mini Series - "M" Models**

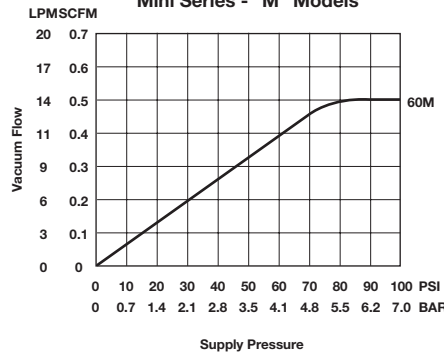

**Static Vacuum vs Supply Pressure
Mini Series - "M" Models**

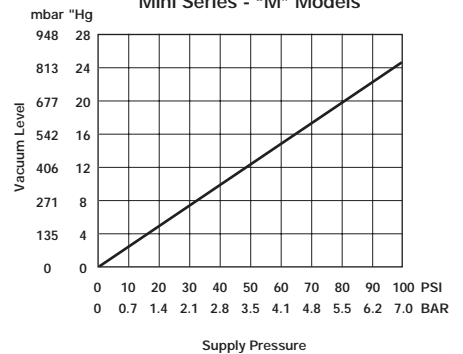

**Air Consumption vs Supply Pressure
Mini Series - "H" Models**

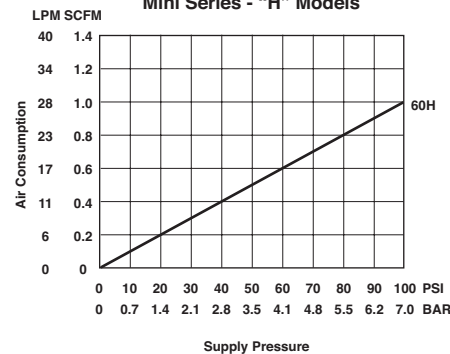

**Vacuum Flow vs Supply Pressure
Mini Series - "H" Models**

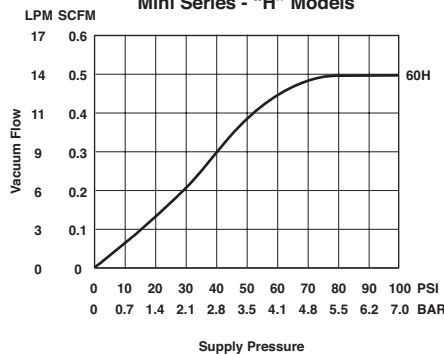

**Static Vacuum vs Supply Pressure
Mini Series - "H" Models**

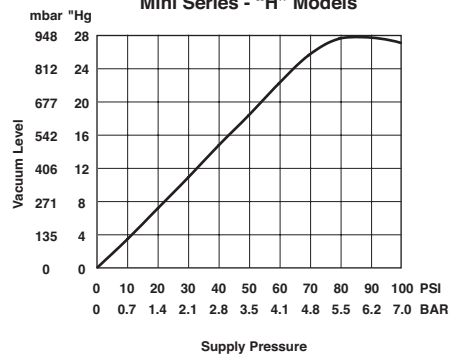

Notes: Standard operating pressure for Norgren generators is 80 PSI [5.5 bar]. Generators can be factory modified to run at other operating pressures i.e. 60 PSI [4.1 bar] etc. The values shown in the performance chart will remain the same for all operating pressures.

Warnings

Improper selection, misuse, age or malfunction of components used in systems can cause failure in various modes. The system designer is warned to consider the failure modes of all component parts and to provide adequate safeguards to prevent personal injury or damage to equipment or property in the event of such failure modes. System designers and end users are cautioned to consult instruction sheets and specifications available from the factory. The system designer/end user is responsible for verifying that all requirements for the application are met.

Warranty

The products described herein are warranted subject to seller's Standard Terms and Condition of Sale, available at seller's website.

- » High Productivity – non-clogging design reduces downtime
- » Strong hold – powerful vacuum up to 28"Hg [948mbar]
- » Mounts Easily – compact and lightweight
- » Fast Response – installs close to vacuum point
- » Efficient – minimal air consumption
- » Reliable operation – straight-through design with no moving parts

Technical Data

Fluid:
Filtered (50 Micron) unlubricated, non-corrosive dry gases

Operating Temperature
-30° to -250° F (-34° to -121°C)

Operating Pressure
80 PSI (5.5 bar) Standard or 60 PSI (4.1 bar)

Materials
Generator Body: Anodized Aluminum
Silencer Body: Nylon

Supply/Vacuum Line
1/4" OD for sizes 60 and 90
3/8" OD for sizes 100 and 150

Mounting Holes
Mounting holes accept 4-40 [M3] screws

Control Valve
3 way/2 position (faster part release), minimum orifice – 0.125" [3mm]

Performance Level Designations
"L", "X" 0-10"Hg [0 to 339mbar] for low vacuum/high flow applications
"M", "Y" 0-20"Hg [0 to 677mbar] for medium vacuum/high flow applications
"H", "Z" 0-28"Hg [0 to 948mbar] for high vacuum/standard flow applications

Product options
Standard (NVP10)
Pneumatic blow-off (NVP1X)
Multi-port (NVP10MO)



Standard Models

Part number	Max. Vacuum Level	Max. Vacuum Flow	Air Consumption	Silencer
NVP10-90M-S05A00	20"Hg	1.40 SCFM	1.40 SCFM	NST4 Silencer
NVP10-90H-S05A00	28"Hg	1.20 SCFM	1.80 SCFM	NST4 Silencer
NVP10-100M-S05A00	20"Hg	2.10 SCFM	1.80 SCFM	NST4 Silencer
NVP10-100H-S05A00	28"Hg	2.00 SCFM	2.80 SCFM	NST4 Silencer
NVP10-150M-S05A00	20"Hg	3.50 SCFM	2.80 SCFM	NST4 Silencer
NVP10-150H-S05A00	28"Hg	3.20 SCFM	4.80 SCFM	NST4 Silencer

Accessories

Option selector

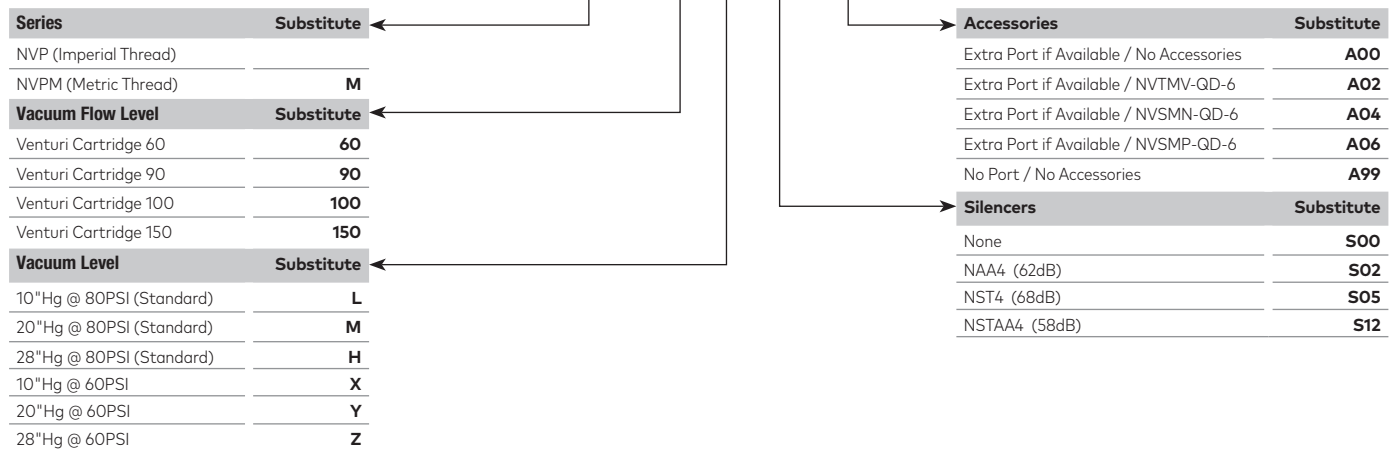



Accessories

Model	Inline Fitting	Swivel Elbow	Vacuum Fitting	Bellows Cup	Flat Cup	Spring Leveler
NVP10-90M-S05A00	124250428	124470428	NVCF13-18M	NBG*****	NFG*****	NVSL2-***
NVP10-90H-S05A00	124250428	124470428	NVCF13-18M	NBG*****	NFG*****	NVSL2-***
NVP10-100M-S05A00	124250628	124470628	NVCF13-18M	NBG*****	NFG*****	NVSL2-***
NVP10-100H-S05A00	124250628	124470628	NVCF13-18M	NBG*****	NFG*****	NVSL2-***
NVP10-150M-S05A00	124250628	124470628	NVCF13-18M	NBG*****	NFG*****	NVSL2-***
NVP10-150H-S05A00	124250628	124470628	NVCF13-18M	NBG*****	NFG*****	NVSL2-***

*Proper selection of vacuum cups depends on the application. Cups are available in various durometers, colors and materials. If you do not see what you are looking for, please consult factory

Dimensions inches (mm)

NVP10- (60, 90, 100, 150) (L, M, H)

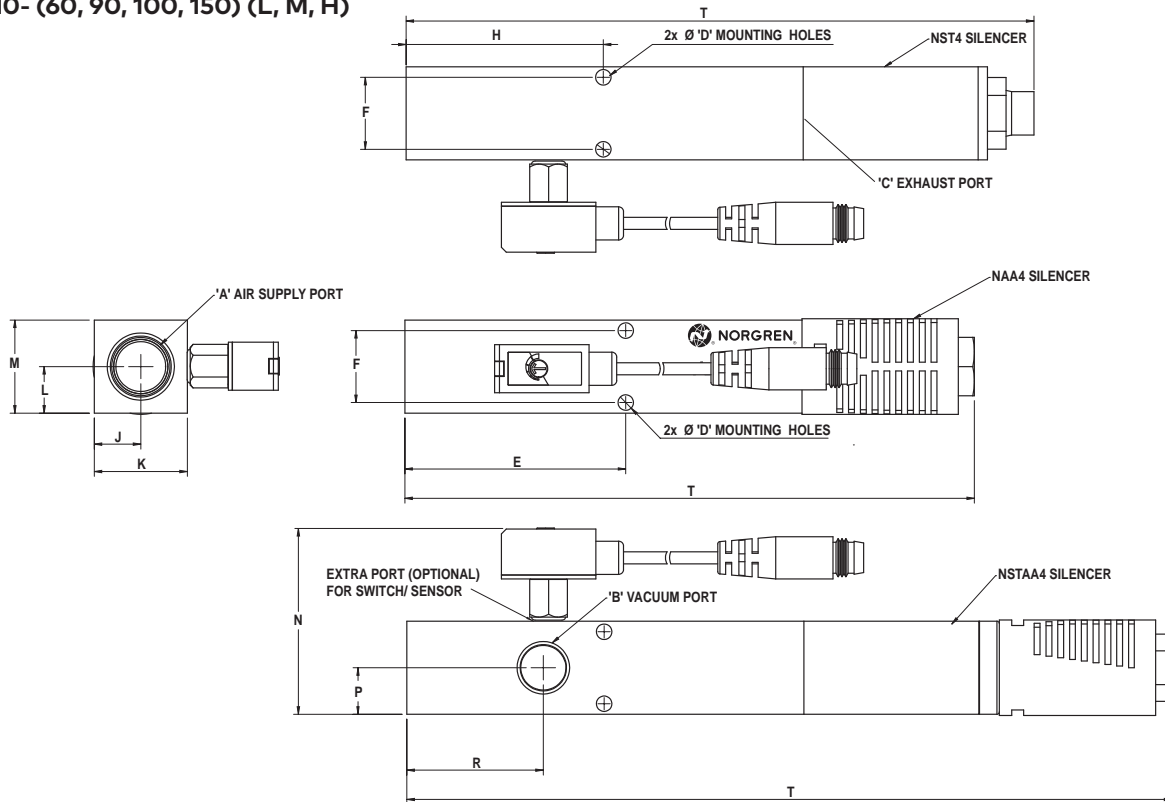

Model	Units	A	B	C	D	E	F	H	J	K	L	M	N	P	R	T
NVP10-***-S02A0*	Imperial	1/4 NPTF	1/8 NPTF	1/4 NPTF	0.12	1.78	0.58	1.59	0.38	0.75	0.38	0.75	1.48	0.38	1.10	4.59
NVP10-***-S05A0*	Imperial	1/4 NPTF	1/8 NPTF	1/4 NPTF	0.12	1.78	0.58	1.59	0.38	0.75	0.38	0.75	1.48	0.38	1.10	5.06
NVP10-***-S12A0*	Imperial	1/4 NPTF	1/8 NPTF	1/4 NPTF	0.12	1.78	0.58	1.59	0.38	0.75	0.38	0.75	1.48	0.38	1.10	6.17
NVPM10-***-S02A0*	(Metric)	(G 1/4)	(G 1/8)	(G 1/4)	(3.1)	(45.2)	(14.7)	(40.4)	(9.5)	(19.1)	(9.5)	(19.1)	(37.6)	(9.5)	(27.9)	(116.6)
NVPM10-***-S05A0*	(Metric)	(G 1/4)	(G 1/8)	(G 1/4)	(3.1)	(45.2)	(14.7)	(40.4)	(9.5)	(19.1)	(9.5)	(19.1)	(37.6)	(9.5)	(27.9)	(128.5)
NVPM10-***-S12A0*	(Metric)	(G 1/4)	(G 1/8)	(G 1/4)	(3.1)	(45.2)	(14.7)	(40.4)	(9.5)	(19.1)	(9.5)	(19.1)	(37.6)	(9.5)	(27.9)	(156.6)



NVP1X

Pneumatic Blow-off

- » All in one vacuum and blow-off - only compressed air required
- » High Productivity – non-clogging design reduces downtime
- » Strong hold – powerful vacuum up to 28"Hg [948mbar]
- » Mounts Easily – compact and lightweight
- » Fast Response – installs close to vacuum point
- » Efficient – minimal air consumption
- » Reliable operation – straight-through design with no moving parts

Technical Data

Fluid
Filtered (50 Micron) unlubricated, non-corrosive dry gases

Operating Temperature
32° to -125° F (0° to -52°C)

Operating Pressure
80 PSI (5.5 bar) Standard or 60 PSI (4.1 bar)

Materials
Generator Body: Anodized Aluminum

Generator Options
B1 adjustable version allows the user to set the intensity of the blow-off from no blow-off to full blow-off

Cycle Rates
Up to 120/min

Blow-off Response Time
Instantaneous

Blow-off Duration
100 milliseconds (based on system design)

Orientation

Any

Supply / Vacuum Line
1/4" OD for sizes 60 and 90
3/8" OD for sizes 100 and 150

Mounting Holes
Mounting holes accept 4-40 [M3] screws



Control Valve

3 way/2 position (faster part release), minimum orifice – 0.125" [3mm]

Performance Level

Designations
"L", "X" 0-10"Hg [0 to 339mbar] for low vacuum/high flow applications
"M", "Y" 0-20"Hg [0 to 677mbar] for medium vacuum/high flow applications
"H", "Z" 0-28"Hg [0 to 948mbar] for high vacuum/standard flow applications

Product options

Standard (NVP10)
Pneumatic blow-off (NVP1X)
Multi-port (NVP10MO)

Standard Models

Part number	Max. Vacuum Level	Max. Vacuum Flow	Air Consumption	Silencer	Blowoff
NVP1XB0-90M-S05A00	20"Hg	1.40 SCFM	1.40 SCFM	NST4 Silencer	Non-Adjustable
NVP1XB0-90H-S05A00	28"Hg	1.20 SCFM	1.80 SCFM	NST4 Silencer	Non-Adjustable
NVP1XB0-100M-S05A00	20"Hg	2.10 SCFM	1.80 SCFM	NST4 Silencer	Non-Adjustable
NVP1XB0-100H-S05A00	28"Hg	2.00 SCFM	2.80 SCFM	NST4 Silencer	Non-Adjustable
NVP1XB0-150M-S05A00	20"Hg	3.50 SCFM	2.80 SCFM	NST4 Silencer	Non-Adjustable
NVP1XB0-150H-S05A00	28"Hg	3.20 SCFM	4.80 SCFM	NST4 Silencer	Non-Adjustable

Accessories

Option selector

NVP 1XB - -S A

Series	Substitute	Accessories	Substitute
NVP (Imperial Thread)		Extra Port if Available / No Accessories	A00
NVPM (Metric Thread)	M	Extra Port if Available / NVTMV-QD-6	A02
Blowoff	Substitute	Extra Port if Available / NVSMN-QD-6	A04
Non-adjustable (Standard)	B0	Extra Port if Available / NVSMP-QD-6	A06
Adjustable	B1	No Port / No Accessories	A99
Vacuum Flow Level	Substitute	Silencers	Substitute
Venturi Cartridge 60	60	None	S00
Venturi Cartridge 90	90	NAA4 (62dB)	S02
Venturi Cartridge 100	100	NST4 (68dB)	S05
Venturi Cartridge 150	150	NSTAA4 (58dB)	S12
Vacuum Level	Substitute		
10"Hg @ 80PSI (Standard)	L		
20"Hg @ 80PSI (Standard)	M		
28"Hg @ 80PSI (Standard)	H		
10"Hg @ 60PSI	X		
20"Hg @ 60PSI	Y		
28"Hg @ 60PSI	Z		





Accessories

Model	Inline Fitting	Swivel Elbow	Vacuum Fitting	Bellows Cup	Flat Cup	Spring Leveler
NVP1XB0-90M-S05A00	124250428	124470428	NVCF13-18M	NBG*****	NFG*****	NVSL3-***
NVP1XB0-90H-S05A00	124250428	124470428	NVCF13-18M	NBG*****	NFG*****	NVSL3-***
NVP1XB0-100M-S05A00	124250628	124470628	NVCF13-18M	NBG*****	NFG*****	NVSL3-***
NVP1XB0-100H-S05A00	124250628	124470628	NVCF13-18M	NBG*****	NFG*****	NVSL3-***
NVP1XB0-150M-S05A00	124250628	124470628	NVCF13-18M	NBG*****	NFG*****	NVSL3-***
NVP1XB0-150H-S05A00	124250628	124470628	NVCF13-18M	NBG*****	NFG*****	NVSL3-***

*Proper selection of vacuum cups depends on the application. Cups are available in various durometers, colors and materials. If you do not see what you are looking for, please consult factory
 *The fittings, cups, and spring levelers listed are a small selection of possible options please refer to the specific catalog section

Dimensions inches (mm)

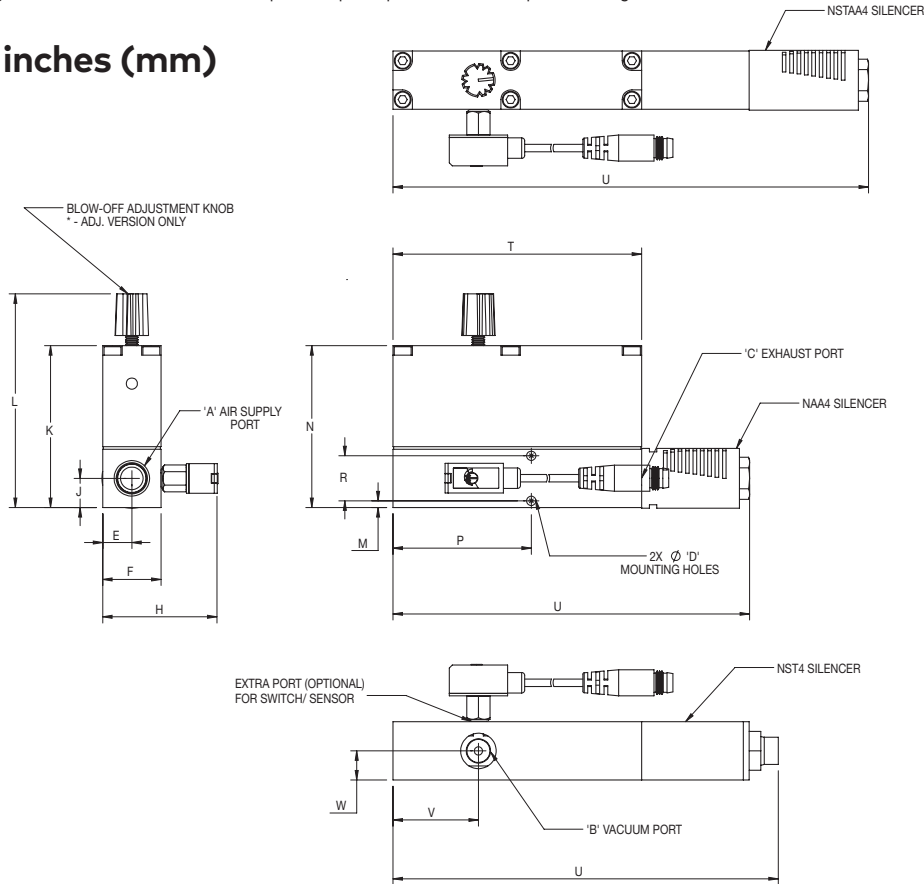

Model	Units	A	B	C	D	E	F	H	J	K	L	M	N	P	R	T	U	V	W
NVP1XB0-***-S02A0*	Imperial	1/4 NPTF	1/8 NPTF	1/4 NPTF	0.12	0.38	0.75	1.49	0.38	2.08	2.75	0.09	2.08	1.78	0.58	3.20	6.18	1.10	0.38
NVP1XB0-***-S05A0*	Imperial	1/4 NPTF	1/8 NPTF	1/4 NPTF	0.12	0.38	0.75	1.49	0.38	2.08	2.75	0.09	2.08	1.78	0.58	3.20	4.60	1.10	0.38
NVP1XB0-***-S12A0*	Imperial	1/4 NPTF	1/8 NPTF	1/4 NPTF	0.12	0.38	0.75	1.49	0.38	2.08	2.75	0.09	2.08	1.78	0.58	3.20	5.06	1.10	0.38
NVPM1XB0-***-S02A0*	(Metric)	(G 1/4)	(G 1/8)	(G 1/4)	(3.1)	(9.7)	(19.1)	(37.8)	(9.5)	(52.8)	(69.9)	(2.3)	(52.8)	(45.2)	(14.7)	(81.3)	(157.0)	(27.9)	(9.5)
NVPM1XB0-***-S05A0*	(Metric)	(G 1/4)	(G 1/8)	(G 1/4)	(3.1)	(9.7)	(19.1)	(37.8)	(9.5)	(52.8)	(69.9)	(2.3)	(52.8)	(45.2)	(14.7)	(81.3)	(117.0)	(27.9)	(9.5)
NVPM1XB0-***-S12A0*	(Metric)	(G 1/4)	(G 1/8)	(G 1/4)	(3.1)	(9.7)	(19.1)	(37.8)	(9.53)	(52.8)	(69.9)	(2.3)	(52.8)	(45.2)	(14.7)	(81.3)	(128.5)	(27.9)	(9.5)



NVP10M

Multi-Port

- » Multi-port version - distribute vacuum to multiple locations
- » High Productivity – non-clogging design reduces downtime
- » Strong hold – powerful vacuum up to 28"Hg [948mbar]
- » Mounts Easily – compact and lightweight
- » Fast Response – installs close to vacuum point
- » Efficient – minimal air consumption
- » Reliable operation – straight-through design with no moving parts

Technical Data

Fluid
Filtered (50 Micron) unlubricated, non-corrosive dry gases

Operating Temperature
-30° to ~250° F (-34° to ~121°C)

Operating Pressure
80 PSI (5.5 bar) Standard or 60 PSI (4.1 bar)

Materials
Generator Body: Anodized Aluminum

Supply / Vacuum Line
1/4" OD for sizes 60 and 90
3/8" OD for sizes 100 and 150

Mounting Holes
Mounting holes accept 4-40 [M3] screws
Control Valve 3 way/2 position (faster part release), minimum orifice – 0.125" [3mm]

Performance Level Designations
"L", "X" 0-10"Hg [0 to 339mbar] for low vacuum/high flow applications
"M", "Y" 0-20"Hg [0 to 677mbar] for medium vacuum/high flow applications
"H", "Z" 0-28"Hg [0 to 948mbar] for high vacuum/standard flow applications

Product options
Standard (NVP10)
Pneumatic blow-off (NVP1X)
Multi-port (NVP10M0)



Standard Models

Part number	Max. Vacuum Level	Max. Vacuum Flow	Air Consumption	Silencer
NVP10M0-90M-S05A00	20"Hg	1.40 SCFM	1.40 SCFM	NST4 Silencer
NVP10M0-90H-S05A00	28"Hg	1.20 SCFM	1.80 SCFM	NST4 Silencer
NVP10M0-100M-S05A00	20"Hg	2.10 SCFM	1.80 SCFM	NST4 Silencer
NVP10M0-100H-S05A00	28"Hg	2.00 SCFM	2.80 SCFM	NST4 Silencer
NVP10M0-150M-S05A00	20"Hg	3.50 SCFM	2.80 SCFM	NST4 Silencer
NVP10M0-150H-S05A00	28"Hg	3.20 SCFM	4.80 SCFM	NST4 Silencer

Accessories

Option selector

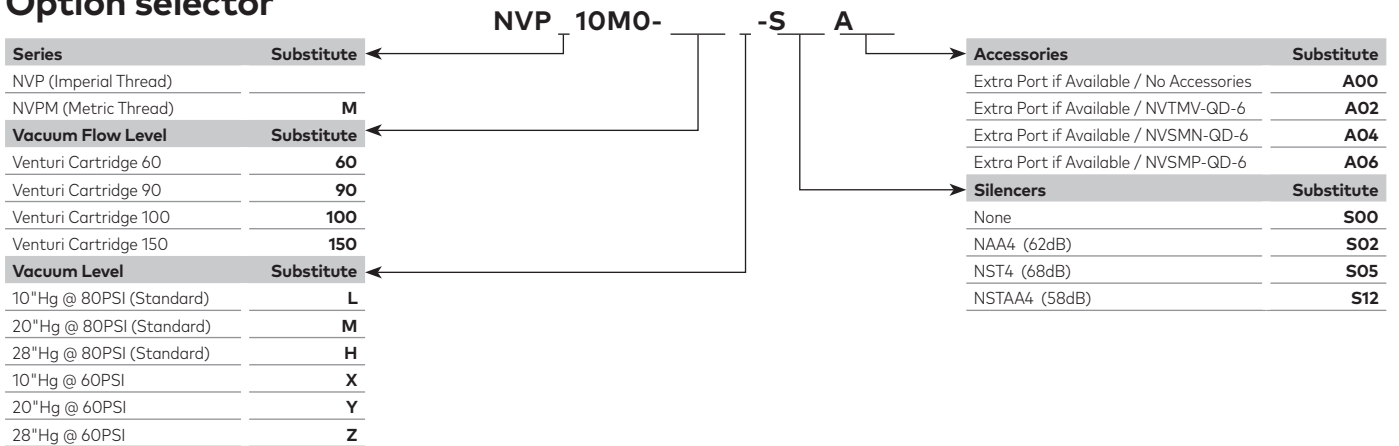



Accessories

Model	Inline Fitting	Swivel Elbow	Vacuum Fitting
NVP10M0-90M-S05A00	124250428	124470428	124470418
NVP10M0-90H-S05A00	124250428	124470428	124470418
NVP10M0-100M-S05A00	124250628	124470628	124470618
NVP10M0-100H-S05A00	124250628	124470628	124470618
NVP10M0-150M-S05A00	124250628	124470628	124470618
NVP10M0-150H-S05A00	124250628	124470628	124470618

*Proper selection of vacuum cups depends on the application. Cups are available in various durometers, colors and materials. If you do not see what you are looking for, please consult factory
 *The fittings, cups, and spring levelers listed are a small selection of possible options please refer to the specific catalog section

Dimensions inches (mm)

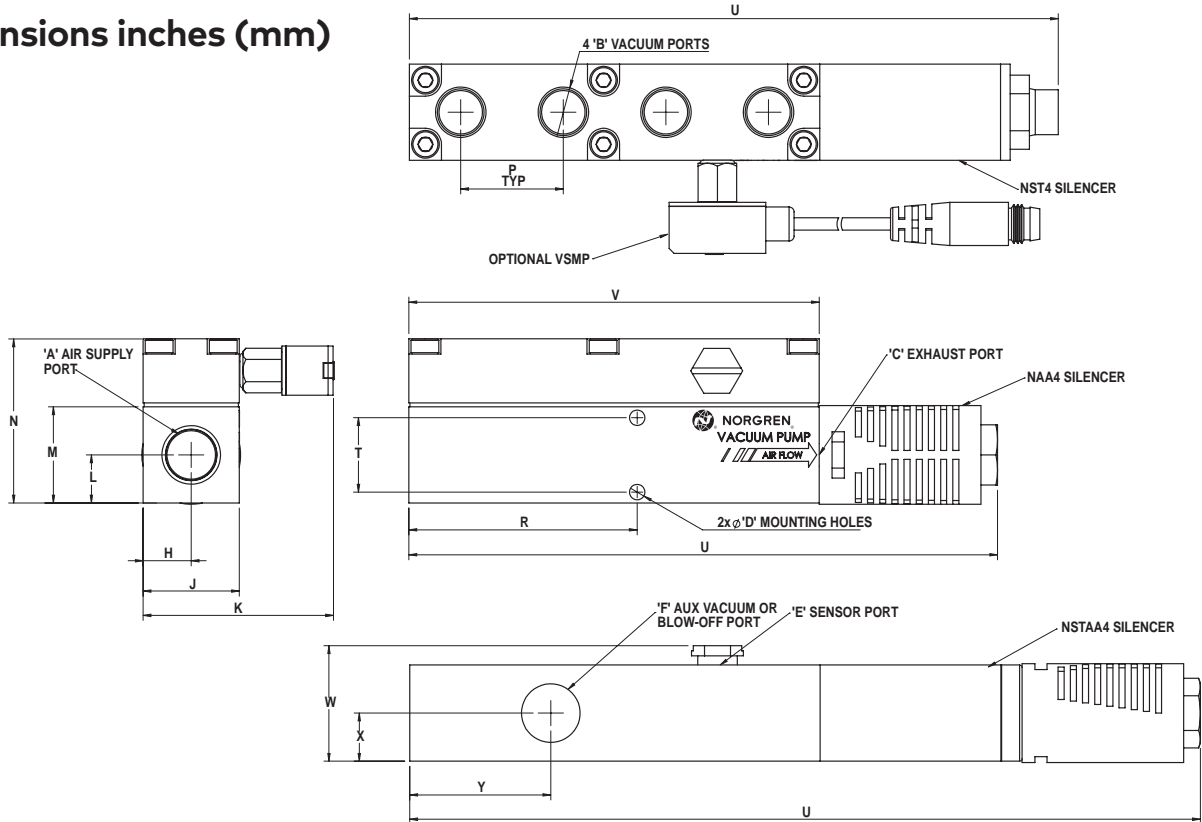

Model	Units	A	B	C	D	E	F	H	J	K	L	M	N	P	R	T	U	V	W
NVP10M0-***-S02A0*	Imperial	1/4 NPTF	1/8 NPTF	1/4 NPTF	0.13	10-32	1/8 NPTF	0.38	0.75	1.49	0.38	0.75	1.28	0.80	1.78	0.58	4.59	3.20	0.92
NVP10M0-***-S05A0*	Imperial	1/4 NPTF	1/8 NPTF	1/4 NPTF	0.13	10-32	1/8 NPTF	0.38	0.75	1.49	0.38	0.75	1.28	0.80	1.78	0.58	5.06	3.20	0.92
NVP10M0-***-S12A0*	Imperial	1/4 NPTF	1/8 NPTF	1/4 NPTF	0.13	10-32	1/8 NPTF	0.38	0.75	1.49	0.38	0.75	1.28	0.80	1.78	0.58	6.17	3.20	0.92
NVPM10M0-***-S02A0*	(Metric)	(G 1/4)	(G 1/8)	(G 1/4)	(3.3)	M5	(G 1/8)	(9.7)	(19.1)	(37.7)	(9.5)	(19.1)	(32.5)	(20.3)	(45.2)	(14.7)	(116.6)	(9.7)	(23.2)
NVPM10M0-***-S05A0*	(Metric)	(G 1/4)	(G 1/8)	(G 1/4)	(3.3)	M5	(G 1/8)	(9.7)	(19.1)	(37.7)	(9.5)	(19.1)	(32.5)	(20.3)	(45.2)	(14.7)	(128.5)	(9.7)	(23.2)
NVPM10M0-***-S12A0*	(Metric)	(G 1/4)	(G 1/8)	(G 1/4)	(3.3)	M5	(G 1/8)	(9.7)	(19.1)	(37.7)	(9.5)	(19.1)	(32.5)	(20.3)	(45.2)	(14.7)	(156.5)	(9.7)	(23.2)

NVP10, NVP1X, AND NVP10M



Performance Data

Model	Air Consumption SCFM (L/min)	Vacuum Level "Hg (mbar)	0"Hg (0)	3"Hg (102)	6"Hg (203)	9"Hg (305)	10"Hg (339)	12"Hg (406)	15"Hg (508)	18"Hg (609)	20"Hg (677)	21"Hg (711)	24"Hg (813)	27"Hg (914)	28"Hg (948)	
90L	0.50 (14.2)	Vacuum Flow SCFM (L/min)	1.30 (36.8)	1.10 (31.1)	0.70 (19.8)	0.20 (5.7)	0.00 (0.0)	- (-)	- (-)	- (-)	- (-)	- (-)	- (-)	- (-)	- (-)	- (-)
		Evacuation time (seconds)	0.00 (0.0)	3.26 (0.1)	7.93 (0.3)	18.65 (0.7)	39.63 (1.4)	- (-)	- (-)	- (-)	- (-)	- (-)	- (-)	- (-)	- (-)	- (-)
100L	1.40 (39.6)	Vacuum Flow SCFM (L/min)	2.10 (59.5)	1.60 (45.3)	1.10 (31.1)	0.50 (14.2)	0.00 (0.0)	- (-)	- (-)	- (-)	- (-)	- (-)	- (-)	- (-)	- (-)	- (-)
		Evacuation time (seconds)	0.00 (0.0)	2.33 (0.1)	4.66 (0.2)	10.88 (0.4)	24.00 (0.9)	- (-)	- (-)	- (-)	- (-)	- (-)	- (-)	- (-)	- (-)	- (-)
150L	1.80 (51)	Vacuum Flow SCFM (L/min)	3.50 (99.1)	2.50 (70.8)	1.90 (53.8)	0.70 (19.8)	0.00 (0.0)	- (-)	- (-)	- (-)	- (-)	- (-)	- (-)	- (-)	- (-)	- (-)
		Evacuation time (seconds)	0.00 (0.0)	1.54 (0.1)	4.36 (0.2)	10.77 (0.4)	22.83 (0.8)	- (-)	- (-)	- (-)	- (-)	- (-)	- (-)	- (-)	- (-)	- (-)
60M	0.50 (14.2)	Vacuum Flow SCFM (L/min)	0.50 (14.2)	0.40 (11.3)	0.30 (8.5)	0.22 (6.2)	- (-)	0.15 (4.2)	0.08 (2.3)	0.03 (0.8)	0.00 (0.0)	- (-)	- (-)	- (-)	- (-)	- (-)
		Evacuation time (seconds)	0.00 (0.0)	12.50 (0.4)	25.10 (0.9)	43.90 (1.6)	- (-)	68.60 (2.4)	99.30 (3.5)	153.70 (5.4)	227.00 (8.0)	- (-)	- (-)	- (-)	- (-)	- (-)
90M	1.40 (39.6)	Vacuum Flow SCFM (L/min)	1.40 (39.6)	1.25 (35.4)	1.20 (34.0)	1.05 (29.7)	- (-)	0.85 (24.1)	0.65 (18.4)	0.25 (7.1)	0.00 (0.0)	- (-)	- (-)	- (-)	- (-)	- (-)
		Evacuation time (seconds)	0.00 (0.0)	3.75 (0.1)	7.20 (0.3)	12.40 (0.4)	- (-)	19.10 (0.7)	29.90 (1.1)	52.00 (1.8)	104.00 (3.7)	- (-)	- (-)	- (-)	- (-)	- (-)
100M	1.80 (51)	Vacuum Flow SCFM (L/min)	2.10 (59.5)	2.00 (56.6)	1.85 (52.4)	1.75 (49.6)	- (-)	1.60 (45.3)	1.25 (35.4)	0.80 (22.7)	0.00 (0.0)	- (-)	- (-)	- (-)	- (-)	- (-)
		Evacuation time (seconds)	0.00 (0.0)	2.65 (0.1)	5.80 (0.2)	9.90 (0.3)	- (-)	16.20 (0.6)	22.90 (0.8)	36.20 (1.3)	56.60 (2.0)	- (-)	- (-)	- (-)	- (-)	- (-)
150M	2.80 (79.3)	Vacuum Flow SCFM (L/min)	3.50 (99.1)	3.20 (90.6)	2.95 (83.5)	2.75 (77.9)	- (-)	2.50 (70.8)	1.80 (51.0)	0.95 (26.9)	0.00 (0.0)	- (-)	- (-)	- (-)	- (-)	- (-)
		Evacuation time (seconds)	0.00 (0.0)	1.35 (0.0)	3.20 (0.1)	5.20 (0.2)	- (-)	7.70 (0.3)	11.80 (0.4)	23.40 (0.8)	52.00 (1.8)	- (-)	- (-)	- (-)	- (-)	- (-)
60H	0.80 (22.7)	Vacuum Flow SCFM (L/min)	0.50 (14.2)	0.38 (10.8)	0.32 (9.1)	0.30 (8.5)	- (-)	0.27 (7.6)	0.23 (6.5)	0.20 (5.7)	- (-)	0.13 (3.7)	0.05 (1.4)	0.02 (0.6)	0.00 (0.0)	0.00 (0.0)
		Evacuation time (seconds)	0.00 (0.0)	15.00 (0.5)	29.80 (1.1)	50.60 (1.8)	- (-)	74.50 (2.6)	102.80 (3.6)	135.90 (4.8)	- (-)	183.20 (6.5)	245.90 (8.7)	410.20 (14.5)	790.80 (27.9)	- (-)
90H	1.80 (51)	Vacuum Flow SCFM (L/min)	1.20 (34.0)	1.00 (28.3)	0.95 (26.9)	0.90 (25.5)	- (-)	0.85 (24.1)	0.75 (21.2)	0.70 (19.8)	- (-)	0.52 (14.7)	0.47 (13.3)	0.20 (5.7)	0.00 (0.0)	0.00 (0.0)
		Evacuation time (seconds)	0.00 (0.0)	6.50 (0.2)	12.30 (0.4)	18.90 (0.7)	- (-)	32.50 (1.1)	47.00 (1.7)	65.40 (2.3)	- (-)	92.20 (3.3)	130.00 (4.6)	222.20 (7.8)	281.30 (9.9)	- (-)
100H	2.80 (79.3)	Vacuum Flow SCFM (L/min)	2.00 (56.6)	1.85 (52.4)	1.75 (49.6)	1.57 (44.5)	- (-)	1.40 (39.6)	1.25 (35.4)	1.05 (29.7)	- (-)	0.84 (23.8)	0.70 (19.8)	0.35 (9.9)	0.00 (0.0)	0.00 (0.0)
		Evacuation time (seconds)	0.00 (0.0)	2.70 (0.1)	6.50 (0.2)	11.20 (0.4)	- (-)	17.50 (0.6)	25.80 (0.9)	38.40 (1.4)	- (-)	55.20 (1.9)	79.20 (2.8)	166.70 (5.9)	251.80 (8.9)	- (-)
150H	4.80 (135.9)	Vacuum Flow SCFM (L/min)	3.20 (90.6)	2.80 (79.3)	2.50 (70.8)	2.30 (65.1)	- (-)	2.00 (56.6)	1.60 (45.3)	1.40 (39.6)	- (-)	1.20 (34.0)	0.80 (22.7)	0.50 (14.2)	0.00 (0.0)	0.00 (0.0)
		Evacuation time (seconds)	0.00 (0.0)	2.30 (0.1)	3.80 (0.1)	6.50 (0.2)	- (-)	10.20 (0.4)	14.20 (0.5)	21.30 (0.8)	- (-)	44.90 (1.6)	55.00 (1.9)	81.00 (2.9)	125.00 (4.4)	- (-)

Evacuation time in seconds based on 1 cubic foot volume / "Hg (1 Liter Volume / mbar)



Performance Data

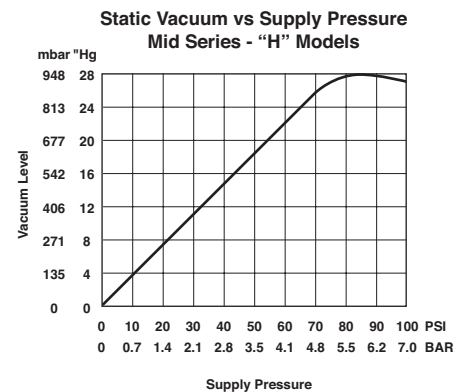
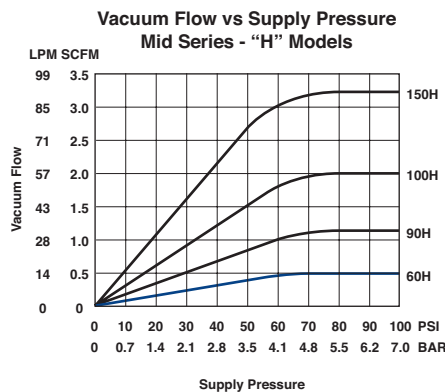
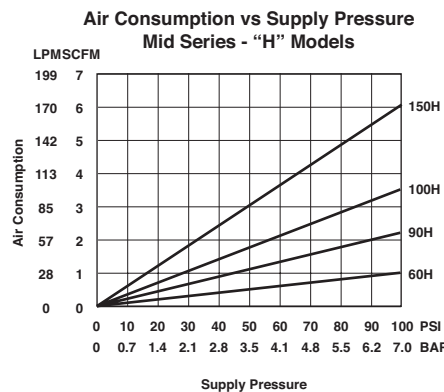
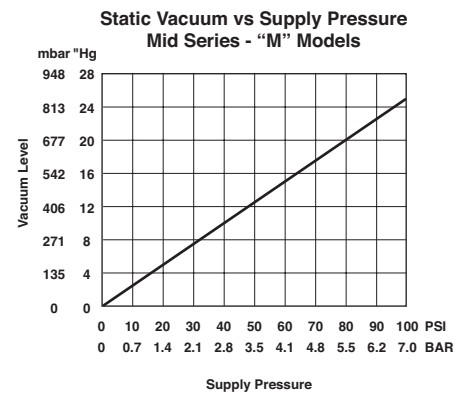
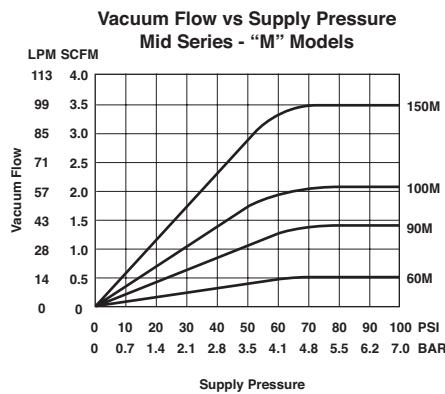
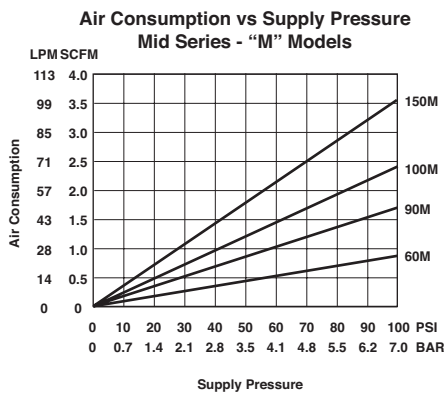
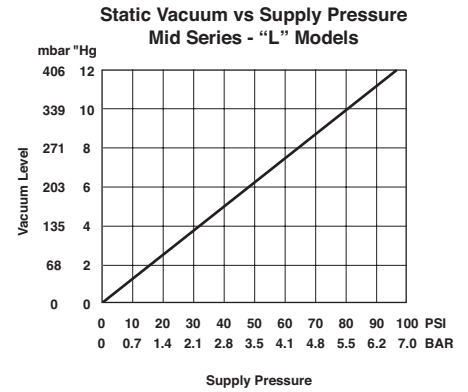
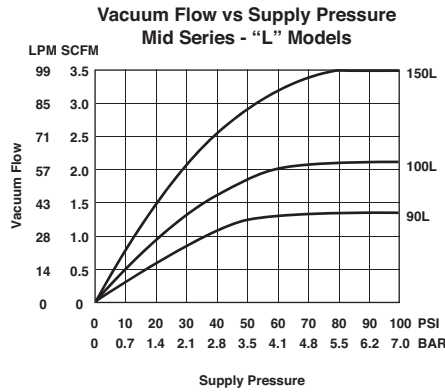
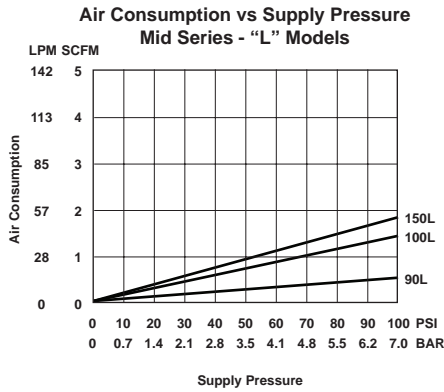

Notes: Standard operating pressure for Norgren generators is 80 PSI [5.5 bar]. Generators can be factory modified to run at other operating pressures i.e. 60 PSI [4.1 bar] etc. The values shown in the performance chart will remain the same for all operating pressures.

Warnings

Improper selection, misuse, age or malfunction of components used in systems can cause failure in various modes. The system designer is warned to consider the failure modes of all component parts and to provide adequate safeguards to prevent personal injury or damage to equipment or property in the event of such failure modes. System designers and end users are cautioned to consult instruction sheets and specifications available from the factory. The system designer/end user is responsible for verifying that all requirements for the application are met.

Warranty

The products described herein are warranted subject to seller's Standard Terms and Condition of Sale, available at seller's website.

- » High Productivity – non-clogging design reduces downtime
- » Strong hold – powerful vacuum up to 28"Hg [948mbar]
- » Mounts Easily – compact and lightweight
- » Fast Response – installs close to vacuum point
- » Efficient – minimal air consumption
- » Reliable operation – straight-through design with no moving parts

Technical Data

Fluid:
Filtered (50 Micron)
unlubricated, non-corrosive
dry gases

Operating Temperature
-30° to ~250° F (-34° to ~121°C C)

Operating Pressure
80 PSI (5.5 bar) Standard or
60 PSI (4.1 bar)

Materials
Generator Body: Anodized
Aluminum

Supply/Vacuum Line
1/4" OD for sizes 60 and 90
3/8" OD for sizes 100 and 150

Mounting Holes
Mounting holes accept 10-32[M5]
screws

Control Valve
3 way/2 position (faster part
release), minimum orifice –
0.125" [3mm]

Performance Level Designations
"L", "X" 0-10"Hg [0 to 339mbar]
for low vacuum/high flow
applications
"M", "Y" 0-20"Hg [0 to 677mbar]
for medium vacuum/high flow
applications
"H", "Z" 0-28"Hg [0 to 948mbar]
for high vacuum/standard flow
applications

Product options
Standard (NVP20)
Pneumatic blow-off (NVP2X)
Valve controlled blow-off
(NVP20V)
Multi-port (NVP20M0)
Air Saver (NVP20CO)



Standard Models

Part number	Max. Vacuum Level	Max. Vacuum Flow	Air Consumption	Silencer
NVP20-90M-S05A00	20"Hg	1.40 SCFM	1.40 SCFM	NST4 Silencer
NVP20-90H-S05A00	28"Hg	1.20 SCFM	1.80 SCFM	NST4 Silencer
NVP20-100M-S05A00	20"Hg	2.10 SCFM	1.80 SCFM	NST4 Silencer
NVP20-100H-S05A00	28"Hg	2.00 SCFM	2.80 SCFM	NST4 Silencer
NVP20-150M-S05A00	20"Hg	3.50 SCFM	2.80 SCFM	NST4 Silencer
NVP20-150H-S05A00	28"Hg	3.20 SCFM	4.80 SCFM	NST4 Silencer

Accessories

Option selector

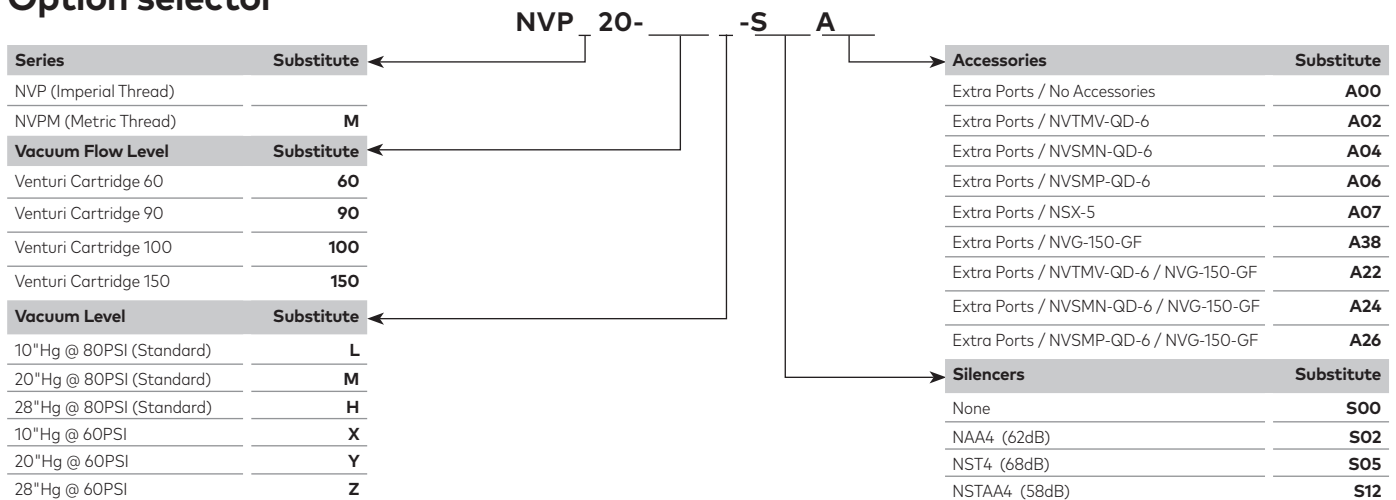



Accessories

Model	Inline Fitting	Swivel Elbow	Vacuum Fitting	Bellows Cup	Flat Cup	Spring Leveler
NVP20-90M-S05A00	124250428	124470428	NVCF45-14M	NBG*****	NFG*****	NVSL3-***
NVP20-90H-S05A00	124250428	124470428	NVCF45-14M	NBG*****	NFG*****	NVSL3-***
NVP20-100M-S05A00	124250628	124470628	NVCF45-14M	NBG*****	NFG*****	NVSL3-***
NVP20-100H-S05A00	124250628	124470628	NVCF45-14M	NBG*****	NFG*****	NVSL3-***
NVP20-150M-S05A00	124250628	124470628	NVCF45-14M	NBG*****	NFG*****	NVSL3-***
NVP20-150H-S05A00	124250628	124470628	NVCF45-14M	NBG*****	NFG*****	NVSL3-***

*Proper selection of vacuum cups depends on the application. Cups are available in various durometers, colors and materials. If you do not see what you are looking for, please consult factory
 *The fittings, cups, and spring levelers listed are a small selection of possible options please refer to the specific catalog section

Dimensions inches (mm)

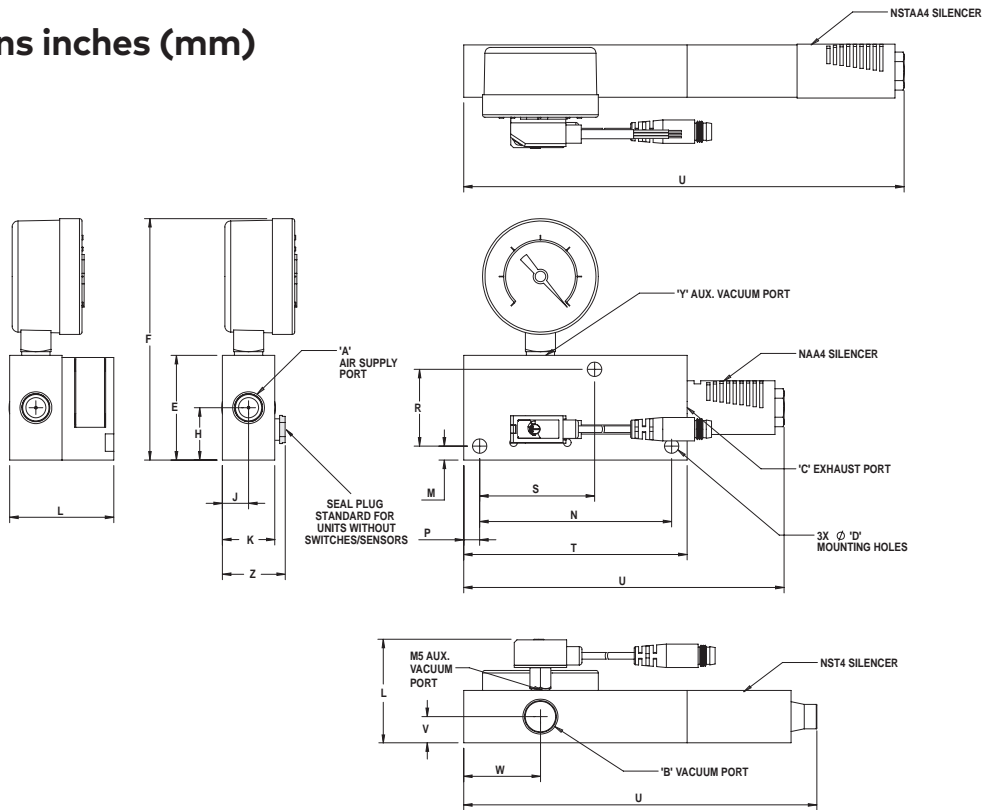

Model	Units	A	B	C	D	E	F	H	J	K	L	M	N	P	R	S	T	U	V	W	Y	Z
NVP20-****-S02A0*	Imperial	1/4 NPTF	1/4 NPTF	1/4 NPTF	0.21	1.50	3.46	0.75	0.38	0.75	N/A	0.20	2.75	0.23	1.10	1.65	3.20	4.59	0.38	1.10	1/8 NPTF	0.92
NVP20-****-S05A0*	Imperial	1/4 NPTF	1/4 NPTF	1/4 NPTF	0.21	1.50	3.46	0.75	0.38	0.75	N/A	0.20	2.75	0.23	1.10	1.65	3.20	5.06	0.38	1.10	1/8 NPTF	0.92
NVP20-****-S12A0*	Imperial	1/4 NPTF	1/4 NPTF	1/4 NPTF	0.21	1.50	3.46	0.75	0.38	0.75	N/A	0.20	2.75	0.23	1.10	1.65	3.20	6.31	0.38	1.10	1/8 NPTF	0.92
NVP20-****-S**A0*	Imperial	1/4 NPTF	1/4 NPTF	1/4 NPTF	0.21	1.50	3.46	0.75	0.38	0.75	1.49	0.20	2.75	0.23	1.10	1.65	3.20	N/A	0.38	1.10	1/8 NPTF	N/A
NVPM20-****-S02A0*	(Metric)	(G 1/4)	(G 1/4)	(G 1/4)	(5.3)	(38.1)	(87.9)	(19.1)	(9.5)	(19.1)	N/A	(5.1)	(69.9)	(5.8)	(27.9)	(41.9)	(81.8)	(116.6)	(9.5)	(27.9)	(G 1/8)	(23.2)
NVPM20-****-S05A0*	(Metric)	(G 1/4)	(G 1/4)	(G 1/4)	(5.3)	(38.1)	(87.9)	(19.1)	(9.5)	(19.1)	N/A	(5.1)	(69.9)	(5.8)	(27.9)	(41.9)	(81.8)	(128.5)	(9.5)	(27.9)	(G 1/8)	(23.2)
NVPM20-****-S12A0*	(Metric)	(G 1/4)	(G 1/4)	(G 1/4)	(5.3)	(38.1)	(87.9)	(19.1)	(9.5)	(19.1)	N/A	(5.1)	(69.9)	(5.8)	(27.9)	(41.9)	(81.8)	(160.3)	(9.5)	(27.9)	(G 1/8)	(23.2)
NVPM20-****-S**A0*	(Metric)	(G 1/4)	(G 1/4)	(G 1/4)	(5.3)	(38.1)	(87.9)	(19.1)	(9.5)	(19.1)	(37.9)	(5.1)	(69.9)	(5.8)	(27.9)	(41.9)	(81.8)	N/A	(9.5)	(27.9)	(G 1/8)	N/A

NVP20V



- » High Productivity – non-clogging design reduces downtime
- » Strong hold – powerful vacuum up to 28"Hg [948mbar]
- » Mounts Easily – compact and lightweight
- » Fast Response – installs close to vacuum point
- » Efficient – minimal air consumption
- » Reliable operation – straight-through design with no moving parts

Technical Data

Fluid:
Filtered (50 Micron)
unlubricated, non-corrosive dry gases

Operating Temperature
-30° to -250° F (-34° to -121°C)
-20° to -120° F (-7° to -49°C)
(Valve)

Operating Pressure
80 PSI (5.5 bar) Standard or
60 PSI (4.1 bar)

Materials
Generator Body: Anodized Aluminum

Supply/Vacuum Line
1/4" OD for sizes 60 and 90
3/8" OD for sizes 100 and 150

Mounting Holes
Mounting holes accept
10-32[M5] screws

Electrical
24V - 5% to 10% (VA/VD,
VB/VE option)
12V - 5% to 10% (VA/VD,
VB/VE option)

Power Consumption
1.6 watts

Response Times
8 milliseconds

Cycle Rate (cycles/second)
45 cycles/second

Electrical Connection
11.8" Flying Leads

LED Indicator with Manual Override
Yes

Control Valve
12V (VC/VF option) or 24V
normally closed (VA/VD option)
or 24V normally open (VB/VE
option)



Performance Level Designations
"L", "X" 0-10"Hg [0 to 339mbar]
for low vacuum/high flow applications
"M", "Y" 0-20"Hg [0 to 677mbar]
for medium vacuum/high flow applications
"H", "Z" 0-28"Hg [0 to 948mbar]
for high vacuum/standard flow applications

Product options
Standard (NVP20)
Pneumatic blow-off (NVP2X)
Valve controlled blow off (NVP20V)
Multi-port (NVP20M)
Air Saver (NVP20C)

Standard Models

Part number	Valve	Max. Vacuum Level	Max. Vacuum Flow	Air Consumption	Silencer	Blow Off
NVP20VA-90M-S05A00	NC 24V	20"Hg	1.40 SCFM	1.40 SCFM	NST4 Silencer	None
NVP20VA-90H-S05A00	NC 24V	28"Hg	1.20 SCFM	1.80 SCFM	NST4 Silencer	None
NVP20VA-100M-S05A00	NC 24V	20"Hg	2.10 SCFM	1.80 SCFM	NST4 Silencer	None
NVP20VA-100H-S05A00	NC 24V	28"Hg	2.00 SCFM	2.80 SCFM	NST4 Silencer	None
NVP20VA-150M-S05A00	NC 24V	20"Hg	3.50 SCFM	2.80 SCFM	NST4 Silencer	None
NVP20VA-150H-S05A00	NC 24V	28"Hg	3.20 SCFM	4.80 SCFM	NST4 Silencer	None
NVP20VD-90M-S05A00	NC 24V	20"Hg	1.40 SCFM	1.40 SCFM	NST4 Silencer	Valve Controlled
NVP20VD-90H-S05A00	NC 24V	28"Hg	1.20 SCFM	1.80 SCFM	NST4 Silencer	Valve Controlled
NVP20VD-100M-S05A00	NC 24V	20"Hg	2.10 SCFM	1.80 SCFM	NST4 Silencer	Valve Controlled
NVP20VD-100H-S05A00	NC 24V	28"Hg	2.00 SCFM	2.80 SCFM	NST4 Silencer	Valve Controlled
NVP20VD-150M-S05A00	NC 24V	20"Hg	3.50 SCFM	2.80 SCFM	NST4 Silencer	Valve Controlled
NVP20VD-150H-S05A00	NC 24V	28"Hg	3.20 SCFM	4.80 SCFM	NST4 Silencer	Valve Controlled

Accessories

Option selector

NVP 20V - -S A

Series	Substitute		Accessories	90
NVP20 (Imperial Thread)			Extra Ports / No Accessories	A00
NVPM20 (Metric Thread)	M		Extra Ports / NVTMV-QD-6	A02
Valve	Substitute		Extra Ports / NVSMN-QD-6	A04
NC 24V Vacuum	VA		Extra Ports / NVSMP-QD-6	A06
NO 24V Vacuum	VB		Extra Ports / NSX-5	A07
NC 12V Vacuum	VC		Extra Ports / NVTMV-QD-6 / NVG-150-GF	A22
NC 24V Vacuum, NC 24V Blow Off	VD		Extra Ports / NVSMN-QD-6 / NVG-150-GF	A24
NO 24V Vacuum, NC 24V Blow Off	VE		Extra Ports / NVSMP-QD-6 / NVG-150-GF	A26
NC 12V Vacuum, NC 12V Blow Off	VF		Extra Ports / NVG-150-GF	A38
Vacuum Level	Substitute	Silencers	Substitute	
10"Hg @ 80PSI (Standard)	L	None	S00	
20"Hg @ 80PSI (Standard)	M	NAA4 (62dB)	S02	
28"Hg @ 80PSI (Standard)	H	NST4 (68dB)	S05	
10"Hg @ 60PSI	X	NSTAA4 (58dB)	S12	
20"Hg @ 60PSI	Y	Vacuum Flow Level	Substitute	
28"Hg @ 60PSI	Z	Venturi Cartridge 60	60	
		Venturi Cartridge 90	90	
		Venturi Cartridge 100	100	
		Venturi Cartridge 150	150	



Accessories

Model	Inline Fitting	Swivel Elbow	Vacuum Fitting	Bellows Cup	Flat Cup	Spring Leveler
NVP20-90M-S05A00	124250428	124470428	NVCF45-14M	NBG*****	NFG*****	NVSL3-***
NVP20-90H-S05A00	124250428	124470428	NVCF45-14M	NBG*****	NFG*****	NVSL3-***
NVP20-100M-S05A00	124250628	124470628	NVCF45-14M	NBG*****	NFG*****	NVSL3-***
NVP20-100H-S05A00	124250628	124470628	NVCF45-14M	NBG*****	NFG*****	NVSL3-***
NVP20-150M-S05A00	124250628	124470628	NVCF45-14M	NBG*****	NFG*****	NVSL3-***
NVP20-150H-S05A00	124250628	124470628	NVCF45-14M	NBG*****	NFG*****	NVSL3-***

*Proper selection of vacuum cups depends on the application. Cups are available in various durometers, colors and materials. If you do not see what you are looking for, please consult factory
 *The fittings, cups, and spring levelers listed are a small selection of possible options please refer to the specific catalog section

Dimensions inches (mm)

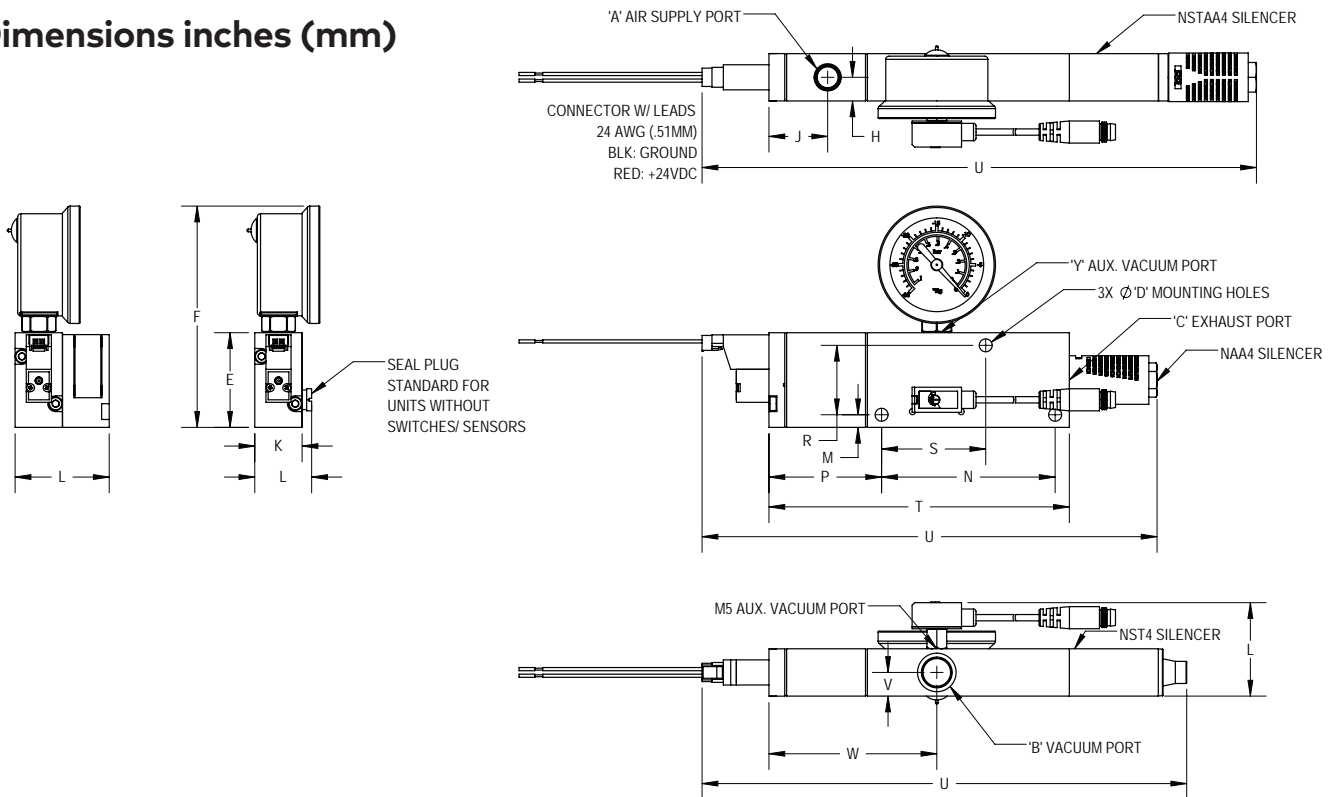

Model	Units	A	B	C	D	E	F	H	J	K	L	M	N	P	R	S	T	U	V	W	Y
NVP20-****-S02A0*	Imperial	1/8 NPTF	1/4 NPTF	1/4 NPTF	0.20	1.50	3.51	0.38	0.93	0.75	0.90	0.20	2.75	1.79	1.10	1.65	4.76	7.21	0.38	2.66	1/8 NPTF
NVP20-****-S05A0*	Imperial	1/8 NPTF	1/4 NPTF	1/4 NPTF	0.20	1.50	3.51	0.38	0.93	0.75	0.90	0.20	2.75	1.79	1.10	1.65	4.76	7.68	0.38	2.66	1/8 NPTF
NVP20-****-S12A0*	Imperial	1/8 NPTF	1/4 NPTF	1/4 NPTF	0.20	1.50	3.51	0.38	0.93	0.75	0.90	0.20	2.75	1.79	1.10	1.65	4.76	8.79	0.38	2.66	1/8 NPTF
NVP20-****-S**A0*	Imperial	1/8 NPTF	1/4 NPTF	1/4 NPTF	0.20	1.50	3.51	0.38	0.93	0.75	1.49	0.20	2.75	1.79	1.10	1.65	4.76	N/A	0.38	2.66	1/8 NPTF
NVPM20-****-S02A0*	(Metric)	(G 1/8)	(G 1/4)	(G 1/4)	(5.1)	(38.1)	(89.2)	(9.7)	(23.6)	(19.1)	(22.9)	(5.1)	(69.9)	(45.5)	(27.9)	(41.9)	(120.9)	(183.1)	(9.7)	(67.6)	(G 1/8)
NVPM20-****-S05A0*	(Metric)	(G 1/8)	(G 1/4)	(G 1/4)	(5.1)	(38.1)	(89.2)	(9.7)	(23.6)	(19.1)	(22.9)	(5.1)	(69.9)	(45.5)	(27.9)	(41.9)	(120.9)	(195.1)	(9.7)	(67.6)	(G 1/8)
NVPM20-****-S12A0*	(Metric)	(G 1/8)	(G 1/4)	(G 1/4)	(5.1)	(38.1)	(89.2)	(9.7)	(23.6)	(19.1)	(22.9)	(5.1)	(69.9)	(45.5)	(27.9)	(41.9)	(120.9)	(223.3)	(9.7)	(67.6)	(G 1/8)
NVPM20-****-S**A0*	(Metric)	(G 1/8)	(G 1/4)	(G 1/4)	(5.1)	(38.1)	(89.2)	(9.7)	(23.6)	(19.01)	(37.9)	(5.1)	(69.9)	(45.5)	(27.9)	(41.9)	(120.9)	N/A	(9.7)	(67.6)	(G 1/8)

Dimensions inches (mm)

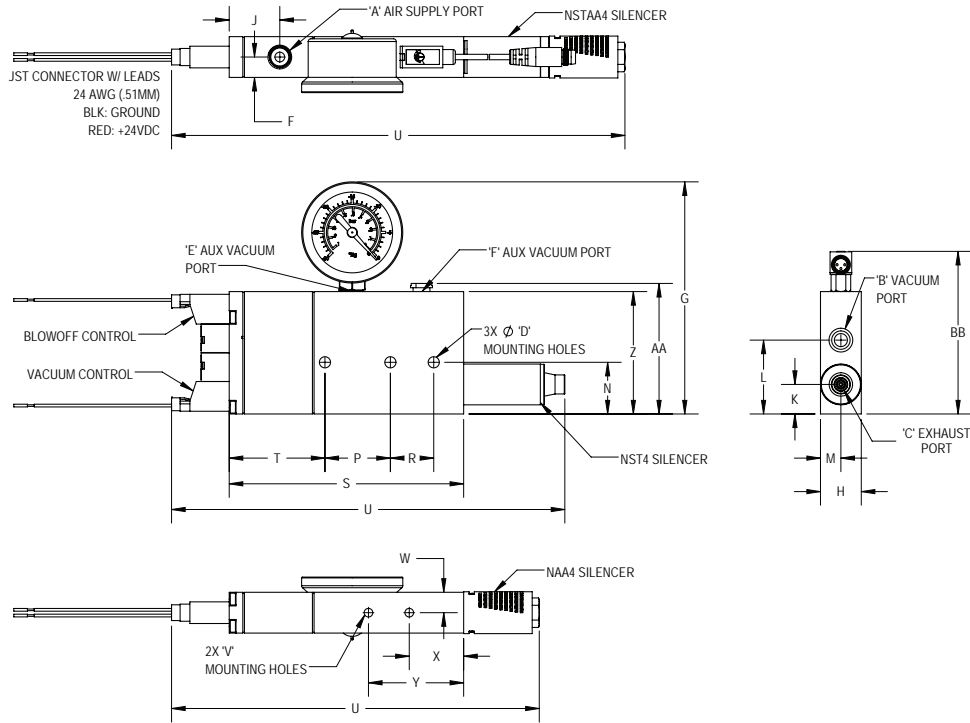

Models	Units	A	B	C	D	E	F	G	H	J	K	L	M	N	P	R	S	T	U	V	W	X	Y	Z	AA	BB
NVP20V*- ***-S00A38	Imperial	1/8 NPTF	1/4 NPTF	1/4 NPTF	0.21	1/8 NPTF	0.38	4.27	0.75	0.93	0.54	1.36	0.38	0.95	1.20	0.80	4.31	1.76	6.76	10-32	0.38	1.00	1.75	2.25	2.40	N/A
NVP20V*- ***-S02A38	Imperial	1/8 NPTF	1/4 NPTF	1/4 NPTF	0.21	1/8 NPTF	0.38	4.27	0.75	0.93	0.54	1.36	0.38	0.95	1.20	0.80	4.31	1.76	7.23	10-32	0.38	1.00	1.75	2.25	2.40	N/A
NVP20V*- ***-S05A38	Imperial	1/8 NPTF	1/4 NPTF	1/4 NPTF	0.21	1/8 NPTF	0.38	4.27	0.75	0.93	0.54	1.36	0.38	0.95	1.20	0.80	4.31	1.76	8.34	10-32	0.38	1.00	1.75	2.25	N/A	3.00
NVP20V*- ***-S12A38	Imperial	1/8 NPTF	1/4 NPTF	1/4 NPTF	0.21	1/8 NPTF	0.38	4.27	0.75	0.93	0.54	1.36	0.38	0.95	1.20	0.80	4.31	1.76	N/A	10-32	0.38	1.00	1.75	2.25	N/A	3.00
NVPM20V*- ***-S00A38	(Metric)	(G 1/8)	(G 1/4)	(G 1/4)	(5.3)	(G 1/8)	(9.7)	(108.5)	(19.0)	(23.6)	(13.7)	(34.5)	(47.6)	(24.1)	(30.5)	(20.3)	(109.5)	(44.7)	(171.7)	(M5)	(9.7)	(25.4)	(44.4)	(57.1)	(61.0)	N/A
NVPM20V*- ***-S02A38	(Metric)	(G 1/8)	(G 1/4)	(G 1/4)	(5.3)	(G 1/8)	(9.7)	(108.5)	(19.0)	(23.6)	(13.7)	(34.5)	(47.6)	(24.1)	(30.5)	(20.3)	(109.5)	(44.7)	(183.6)	(M5)	(9.7)	(25.4)	(44.4)	(57.1)	(61.0)	N/A
NVPM20V*- ***-S05A38	(Metric)	(G 1/8)	(G 1/4)	(G 1/4)	(5.3)	(G 1/8)	(9.7)	(108.5)	(19.0)	(23.6)	(13.7)	(34.5)	(47.6)	(24.1)	(30.5)	(20.3)	(109.5)	(44.7)	(211.8)	(M5)	(9.7)	(25.4)	(44.4)	(57.1)	N/A	(76.2)
NVPM20V*- ***-S12A38	(Metric)	(G 1/8)	(G 1/4)	(G 1/4)	(5.3)	(G 1/8)	(9.7)	(108.5)	(19.0)	(23.6)	(13.7)	(34.5)	(47.6)	(24.1)	(30.5)	(20.3)	(109.5)	(44.7)	N/A	(M5)	(9.7)	(25.4)	(44.4)	(57.1)	N/A	(76.2)

NVP2X

Pneumatic Blow-off



- » All in one vacuum and blow-off - only compressed air required
- » High Productivity - non-clogging design reduces downtime
- » Strong hold - powerful vacuum up to 28"Hg [948mbar]
- » Mounts Easily - compact and lightweight
- » Fast Response - installs close to vacuum point
- » Efficient - minimal air consumption
- » Reliable operation - straight-through design with no moving parts

Technical Data

Fluid: Filtered (50 Micron) unlubricated, non-corrosive dry gases
Operating Temperature 32° to ~125° F (0° to ~52°C)
 20° to ~120° F (-7° to ~49°C) (Valve)
Operating Pressure 80 PSI (5.5 bar) Standard or 60 PSI (4.1 bar)
Materials Generator Body: Anodized Aluminum
Generator Options B1 adjustable version allows the user to set the intensity of the blow-off from no blow-off to full blow-off
Cycle Rates 45 cycles/sec., Up to 120/min
Blow-off Response Time Instantaneous
 Pneumatic blow-off
Blow-off Duration 100 milliseconds (based on system design)

Orientation Any
Electrical 24V - 5% to 10% (VA/VD,VB/VE option)
 12V - 5% to 10% (VC/VF option)
Power Consumption 1.6 watts
Response Times 8 milliseconds
Average Valve Life 50 million cycles
Electrical Connection 11.8" Flying Lead
LED Indicator with Manual Override Yes
Supply/Vacuum Line 1/4" OD for sizes 60 and 90
 3/8" OD for sizes 100 and 150
Mounting Holes Mounting holes accept 10-32 [M5] screws
Control Valve 12V (VC/VF option) or 24V normally closed (VA/VD option) or 24V normally open (VB/VE option)



Performance Level Designations
 "L", "X" 0-10"Hg [0 to 339mbar] for low vacuum/high flow applications
 "M", "Y" 0-20"Hg [0 to 677mbar] for medium vacuum/high flow applications
 "H", "Z" 0-28"Hg [0 to 948mbar] for high vacuum/standard flow applications
Product Options Standard (NVP20) Pneumatic blow-off (NVP2X) Valve controlled blow-off (NVP20V) Multi-port (NVP20M) Air Saver (NVP20C)

Standard Models

Part number	Valve	Max. Vacuum Level	Max. Vacuum Flow	Air Consumption	Silencer	Blowoff
NVP2XB0-90M-S05A00	None	20"Hg	1.40 SCFM	1.40 SCFM	NST4 Silencer	Non-Adjustable
NVP2XB0-90H-S05A00	None	28"Hg	1.20 SCFM	1.80 SCFM	NST4 Silencer	Non-Adjustable
NVP2XB0-100M-S05A00	None	20"Hg	2.10 SCFM	1.80 SCFM	NST4 Silencer	Non-Adjustable
NVP2XB0-100H-S05A00	None	28"Hg	2.00 SCFM	2.80 SCFM	NST4 Silencer	Non-Adjustable
NVP2XB0-150M-S05A00	None	20"Hg	3.50 SCFM	2.80 SCFM	NST4 Silencer	Non-Adjustable
NVP2XB0-150H-S05A00	None	28"Hg	3.20 SCFM	4.80 SCFM	NST4 Silencer	Non-Adjustable
NVP2XBA-90M-S05A00	NC 24V	20"Hg	1.40 SCFM	1.40 SCFM	NST4 Silencer	Non-Adjustable
NVP2XBA-90H-S05A00	NC 24V	28"Hg	1.20 SCFM	1.80 SCFM	NST4 Silencer	Non-Adjustable
NVP2XBA-100M-S05A00	NC 24V	20"Hg	2.10 SCFM	1.80 SCFM	NST4 Silencer	Non-Adjustable
NVP2XBA-100H-S05A00	NC 24V	28"Hg	2.00 SCFM	2.80 SCFM	NST4 Silencer	Non-Adjustable
NVP2XBA-150M-S05A00	NC 24V	20"Hg	3.50 SCFM	2.80 SCFM	NST4 Silencer	Non-Adjustable
NVP2XBA-150H-S05A00	NC 24V	28"Hg	3.20 SCFM	4.80 SCFM	NST4 Silencer	Non-Adjustable

Accessories

Option selector

Series		Substitute		NVP 2XB -		-S		A		Accessories		Substitute	
NVP (Imperial Thread)										Extra Port if Available / No Accessories		A00	
NVP (Metric Thread)		M								Extra Port if Available / NVTMV-QD-6		A02	
Blowoff		Substitute								Extra Port if Available / NVSMN-QD-6		A04	
Non-adjustable, No valve		BO								Extra Port if Available / NVSMP-QD-6		A06	
Adjustable, No valve		B1								Extra Port if Available / NSX-5		A07	
Non-Adjustable, NC 24V Vacuum		BA								Silencers		Substitute	
Non-Adjustable, NO 24V Vacuum		BB								None		S00	
Non-Adjustable, NC 12V Vacuum		BC								NAA4 (62dB)		S02	
Adjustable, NC 24V Vacuum		BD								NST4 (68dB)		S05	
Adjustable, NO 24V Vacuum		BE								NSTAA4 (58dB)		S12	
Adjustable, NC 12V Vacuum		BF								Vacuum Level		Substitute	
Non-Adjustable, NC 24V Rnd Body Vacuum		BG								10"Hg @ 80PSI (Standard)		L	
Non-Adjustable, NC 24V Rnd Body Vacuum, M8		BH				Vacuum Flow Level		Substitute		20"Hg @ 80PSI (Standard)		M	
Adjustable, NC 24V Rnd Body Vacuum		BJ				Venturi Cartridge 60		60		28"Hg @ 80PSI (Standard)		H	
Adjustable, NC 24V Rnd Body Vacuum		BK				Venturi Cartridge 90		90		10"Hg @ 60PSI		X	
						Venturi Cartridge 100		100		20"Hg @ 60PSI		Y	
						Venturi Cartridge 150		150		28"Hg @ 60PSI		Z	



NVP2X

Pneumatic Blow-off



Accessories

Model	Inline Fitting	Swivel Elbow	Vacuum Fitting	Bellows Cup	Flat Cup	Spring Leveler
NVP2X-90M-S05A00	124250428	124470428	NVCF45-14M	NBG*****	NFG*****	NVSL3-***
NVP2X-90H-S05A00	124250428	124470428	NVCF45-14M	NBG*****	NFG*****	NVSL3-***
NVP2X-100M-S05A00	124250628	124470628	NVCF45-14M	NBG*****	NFG*****	NVSL3-***
NVP2X-100H-S05A00	124250628	124470628	NVCF45-14M	NBG*****	NFG*****	NVSL3-***
NVP2X-150M-S05A00	124250628	124470628	NVCF45-14M	NBG*****	NFG*****	NVSL3-***
NVP2X-150H-S05A00	124250628	124470628	NVCF45-14M	NBG*****	NFG*****	NVSL3-***

*Proper selection of vacuum cups depends on the application. Cups are available in various durometers, colors and materials. If you do not see what you are looking for, please consult factory
 *The fittings, cups, and spring levelers listed are a small selection of possible options please refer to the specific catalog section

Dimensions inches (mm)

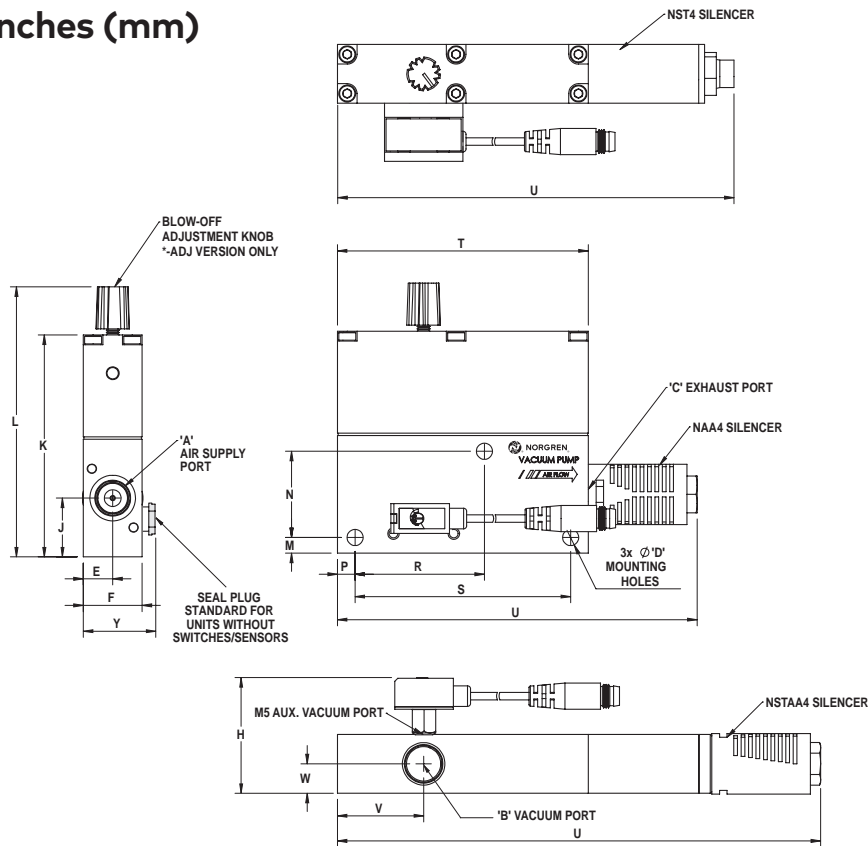

Model	Units	A	B	C	D	E	F	H	J	K	L	M	N	P	R	S	T	U	V	W	Y
NVP2XB0-****-S02A0*	Imperial	1/4 NPTF	1/4 NPTF	1/4 NPTF	0.21	0.38	0.75	1.49	0.75	2.83	3.49	0.20	1.10	0.23	1.65	2.75	3.20	4.59	1.10	0.375	0.92
NVP2XB0-****-S05A0*	Imperial	1/4 NPTF	1/4 NPTF	1/4 NPTF	0.21	0.38	0.75	1.49	0.75	2.83	3.49	0.20	1.10	0.23	1.65	2.75	3.20	5.06	1.10	0.375	0.92
NVP2XB0-****-S12A0*	Imperial	1/4 NPTF	1/4 NPTF	1/4 NPTF	0.21	0.38	0.75	1.49	0.75	2.83	3.49	0.20	1.10	0.23	1.65	2.75	3.20	6.31	1.10	0.375	0.92
NVPM2XB0-****-S02A0*	(Metric)	(G 1/4)	(G 1/4)	(G 1/4)	(5.3)	(9.7)	(19.1)	(37.9)	(19.1)	(71.9)	(88.7)	(5.1)	(27.9)	(5.8)	(41.9)	(69.9)	(81.8)	(116.6)	(27.9)	(9.5)	(23.2)
NVPM2XB0-****-S05A0*	(Metric)	(G 1/4)	(G 1/4)	(G 1/4)	(5.3)	(9.7)	(19.1)	(37.9)	(19.1)	(71.9)	(88.7)	(5.1)	(27.9)	(5.8)	(41.9)	(69.9)	(81.8)	(128.5)	(27.9)	(9.5)	(23.2)
NVPM2XB0-****-S12A0*	(Metric)	(G 1/4)	(G 1/4)	(G 1/4)	(5.3)	(9.7)	(19.1)	(37.9)	(19.1)	(71.9)	(88.7)	(5.1)	(27.9)	(5.8)	(41.9)	(69.9)	(81.8)	(160.3)	(27.9)	(9.5)	(23.2)



Accessories

Model	Inline Fitting	Swivel Elbow	Vacuum Fitting	Bellows Cup	Flat Cup	Spring Leveler
NVP2X-90M-S05A00	124250428	124470428	NVCF45-14M	NBG*****	NFG*****	NVSL3-***
NVP2X-90H-S05A00	124250428	124470428	NVCF45-14M	NBG*****	NFG*****	NVSL3-***
NVP2X-100M-S05A00	124250628	124470628	NVCF45-14M	NBG*****	NFG*****	NVSL3-***
NVP2X-100H-S05A00	124250628	124470628	NVCF45-14M	NBG*****	NFG*****	NVSL3-***
NVP2X-150M-S05A00	124250628	124470628	NVCF45-14M	NBG*****	NFG*****	NVSL3-***
NVP2X-150H-S05A00	124250628	124470628	NVCF45-14M	NBG*****	NFG*****	NVSL3-***

*Proper selection of vacuum cups depends on the application. Cups are available in various diameters, colors and materials. If you do not see what you are looking for, please consult factory
 *The fittings, cups, and spring levelers listed are a small selection of possible options please refer to the specific catalog section

Dimensions inches (mm)

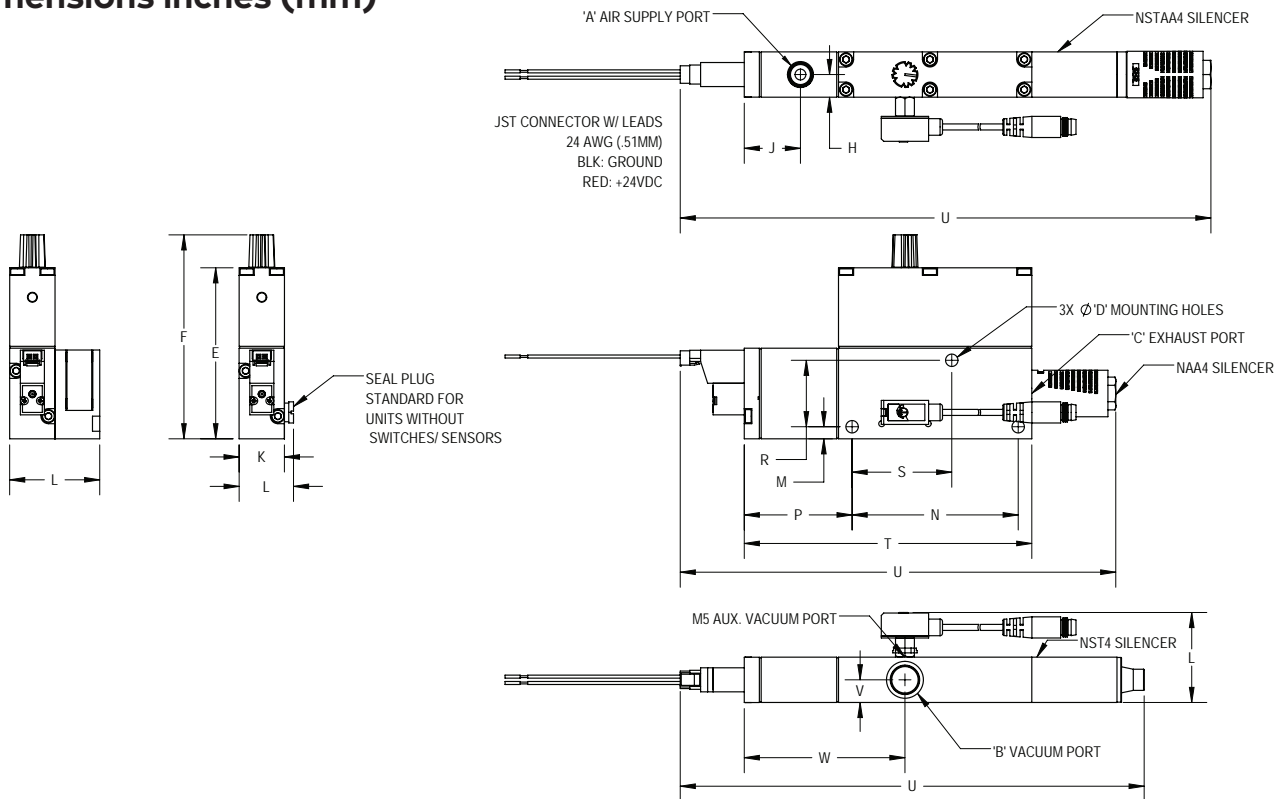

Model	Units	A	B	C	D	E	F	H	J	K	L	M	N	P	R	S	T	U	V	W
NVP2XB0-****-S02A0*	Imperial	1/8 NPTF	1/4 NPTF	1/4 NPTF	0.20	2.83	3.38	0.38	0.93	0.75	0.90	0.20	2.75	1.79	1.10	1.65	4.76	7.21	0.38	2.66
NVP2XB0-****-S05A0*	Imperial	1/8 NPTF	1/4 NPTF	1/4 NPTF	0.20	2.83	3.38	0.38	0.93	0.75	0.90	0.20	2.75	1.79	1.10	1.65	4.76	7.68	0.38	2.66
NVP2XB0-****-S12A0*	Imperial	1/8 NPTF	1/4 NPTF	1/4 NPTF	0.20	2.83	3.38	0.38	0.93	0.75	0.90	0.20	2.75	1.79	1.10	1.65	4.76	8.79	0.38	2.66
NVP2XB0-****-S**A0*	Imperial	1/8 NPTF	1/4 NPTF	1/4 NPTF	0.20	2.83	3.38	0.38	0.93	0.75	1.49	0.20	2.75	1.79	1.10	1.65	4.76	N/A	0.38	2.66
NVPM2XB0-****-S02A0*	(Metric)	(G 1/8)	(G 1/4)	(G 1/4)	(5.1)	(71.9)	(85.9)	(9.7)	(23.6)	(19.0)	(22.9)	(5.1)	(69.8)	(45.5)	(27.9)	(41.9)	(120.9)	(183.1)	(9.7)	(67.6)
NVPM2XB0-****-S05A0*	(Metric)	(G 1/8)	(G 1/4)	(G 1/4)	(5.1)	(71.9)	(85.9)	(9.7)	(23.6)	(19.0)	(22.9)	(5.1)	(69.8)	(45.5)	(27.9)	(41.9)	(120.9)	(195.1)	(9.7)	(67.6)
NVPM2XB0-****-S12A0*	(Metric)	(G 1/8)	(G 1/4)	(G 1/4)	(5.1)	(71.9)	(85.9)	(9.7)	(23.6)	(19.0)	(22.9)	(5.1)	(69.8)	(45.5)	(27.9)	(41.9)	(120.9)	(223.3)	(9.7)	(67.6)
NVPM2XB0-****-S**A0*	(Metric)	(G 1/8)	(G 1/4)	(G 1/4)	(5.1)	(71.9)	(85.9)	(9.7)	(23.6)	(19.0)	(37.8)	(5.1)	(69.8)	(45.5)	(27.9)	(41.9)	(120.9)	N/A	(9.7)	(67.6)

NVP20M

Multi-Port



- » Multi-port version - distribute vacuum to multiple locations
- » High Productivity – non-clogging design reduces downtime
- » Strong hold – powerful vacuum up to 28"Hg [948mbar]
- » Mounts Easily – compact and lightweight
- » Fast Response – installs close to vacuum point
- » Efficient – minimal air consumption
- » Reliable operation – straight-through design with no moving parts

Technical Data

Fluid:
Filtered (50 Micron) unlubricated, non-corrosive dry gases

Operating Temperature
-30° to ~250° F (-34° to ~121°C)
20° to ~120° F (-7° to ~49°C)
(Valve Option)

Operating Pressure
80 PSI (5.5 bar) Standard or
60 PSI (4.1 bar)

Materials
Generator Body: Anodized Aluminum

Supply/Vacuum Line
1/4" OD for sizes 60 and 90
3/8" OD for sizes 100 and 150

Mounting Holes
Mounting holes accept 10-32 [M5] screws
Electrical
24V - 5% to 10% (VA/VD, VB/VE option)
12V - 5% to 10% (VC/VF option)

Power Consumption
1.6 watts

Response Times
8 milliseconds

Cycle Rate (cycles/second)
45 cycles/second

Average Valve Life
50 million cycles

Electrical Connection
11.8" Flying Lead

LED Indicator with Manual Override
Yes

Control Valve
12V (VC/VF option) or 24V normally closed (VA/VD option) or 24V normally open (VB/VE option)

Performance Level Designations
"L", "X" 0-10"Hg [0 to 339mbar] for low vacuum/high flow applications
"M", "Y" 0-20"Hg [0 to 677mbar]



for medium vacuum/high flow applications
"H", "Z" 0-28"Hg [0 to 948mbar] for high vacuum/standard flow applications vacuum/high flow applications

Product options
Standard (NVP20)
Pneumatic blow-off (NVP2X)
Valve controlled blow-off (NVP20V)
Multi-port (NVP20M)
Air Saver (NVP20C)

Standard Models

Part number	Valve	Max. Vacuum Level	Max. Vacuum Flow	Air Consumption	Silencer
NVP20M0-90M-S05A38	None	20"Hg	1.40 SCFM	1.40 SCFM	NST4 Silencer
NVP20M0-90H-S05A38	None	28"Hg	1.20 SCFM	1.80 SCFM	NST4 Silencer
NVP20M0-100M-S05A38	None	20"Hg	2.10 SCFM	1.80 SCFM	NST4 Silencer
NVP20M0-100H-S05A38	None	28"Hg	2.00 SCFM	2.80 SCFM	NST4 Silencer
NVP20M0-150M-S05A38	None	20"Hg	3.50 SCFM	2.80 SCFM	NST4 Silencer
NVP20M0-150H-S05A38	None	28"Hg	3.20 SCFM	4.80 SCFM	NST4 Silencer
NVP20MA-090M-S05A38	NC 24V	20"Hg	1.40 SCFM	1.40 SCFM	NST4 Silencer
NVP20MA-090H-S05A38	NC 24V	28"Hg	1.20 SCFM	1.80 SCFM	NST4 Silencer
NVP20MA-100M-S05A38	NC 24V	20"Hg	2.10 SCFM	1.80 SCFM	NST4 Silencer
NVP20MA-100H-S05A38	NC 24V	28"Hg	2.00 SCFM	2.80 SCFM	NST4 Silencer
NVP20MA-150M-S05A38	NC 24V	20"Hg	3.50 SCFM	2.80 SCFM	NST4 Silencer
NVP20MA-150H-S05A38	NC 24V	28"Hg	3.20 SCFM	4.80 SCFM	NST4 Silencer

Accessories

Option selector

Series	Substitute	NVP 20M - S A		Accessories	Substitute
NVP (Imperial Thread)				Extra Ports / NVG-150-GF	A38
NVPM (Metric Thread)	M			Extra Ports / NVTMV-QD-6 / NVG-150-GF	A22
Valve	Substitute			Extra Ports / NVSMN-QD-6 / NVG-150-GF	A24
Multi-Port, No Valve	MO			Extra Ports / NVSMP-QD-6 / NVG-150-GF	A26
Multi-Port, NC 24V Vacuum	MA			Extra Ports / No Accessories (standard)	A00
Multi-Port, NO 24V Vacuum	MB			Extra Ports / NVTMV-QD-6	A02
Multi-Port, NC 12V Vacuum	MC			Extra Ports / NVSMN-QD-6	A04
Vacuum Flow Level	Substitute			Extra Ports / NVSMP-QD-6	A06
Venturi Cartridge 60	60			Gauge Port Only / No Accessories	A98
Venturi Cartridge 90	90				
Venturi Cartridge 100	100				
Venturi Cartridge 150	150				
Vacuum Level	Substitute			Silencers	Substitute
10"Hg @ 80PSI (Standard)	L			None	S00
20"Hg @ 80PSI (Standard)	M			NAA4 (62dB)	S02
28"Hg @ 80PSI (Standard)	H			NST4 (68dB)	S05
10"Hg @ 60PSI	X			NSTAA4 (58dB)	S12
20"Hg @ 60PSI	Y				
28"Hg @ 60PSI	Z				



Accessories

Model	Inline Fitting	Pneufit Swivel Male Elbow
NVP20M0-90M-S05A38	124250428	124470428
NVP20M0-90H-S05A38	124250428	124470428
NVP20M0-100M-S05A38	124250628	124470628
NVP20M0-100H-S05A38	124250628	124470628
NVP20M0-150M-S05A38	124250628	124470628
NVP20M0-150H-S05A38	124250628	124470628

*Proper selection of vacuum cups depends on the application. Cups are available in various durometers, colors and materials. If you do not see what you are looking for, please consult factory
 *The fittings, cups, and spring levelers listed are a small selection of possible options please refer to the specific catalog section

Dimensions inches (mm)

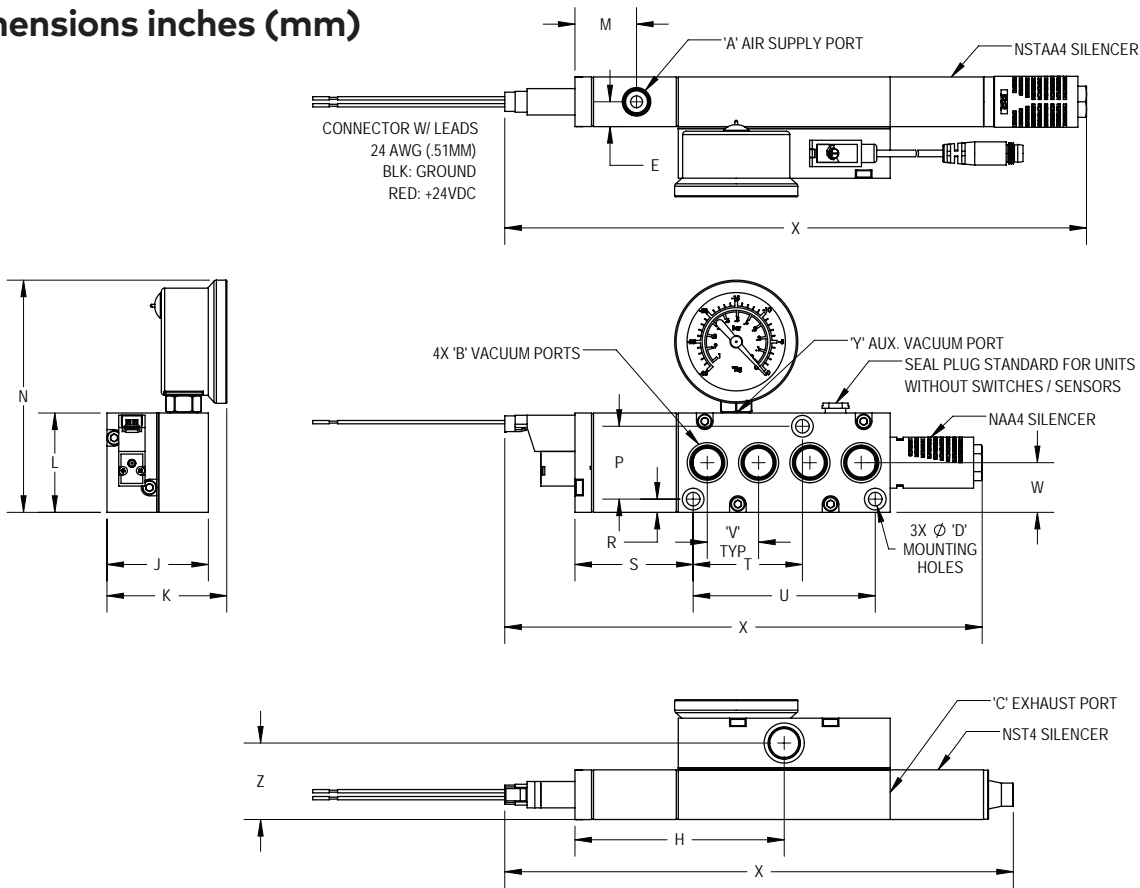

Model	Units	A	B	C	D	E	F	H	J	K	L	M	N	P	R	S	T	U	V	W	X	Y	Z
NVP20M0-***-S02A38	Imperial	1/8 NPTF	1/4 NPTF	1/4 NPTF	0.20	0.37	1/4 NPTF	3.16	1.53	1.81	1.50	0.93	3.51	1.10	0.20	1.79	1.65	2.75	0.78	0.75	7.21	1/8 NPT F	1.16
NVP20M0-***-S05A38	Imperial	1/8 NPTF	1/4 NPTF	1/4 NPTF	0.20	0.37	1/4 NPTF	3.16	1.53	1.81	1.50	0.93	3.51	1.10	0.20	1.79	1.65	2.75	0.78	0.75	7.68	1/8 NPT F	1.16
NVP20M0-***-S12A38	Imperial	1/8 NPTF	1/4 NPTF	1/4 NPTF	0.20	0.37	1/4 NPTF	3.16	1.53	1.81	1.50	0.93	3.51	1.10	0.20	1.79	1.65	2.75	0.78	0.75	8.79	1/8 NPT F	1.16
NVPM20M0-***-S02A38	(Metric)	(G 1/8)	(G 1/4)	(G 1/4)	(5.1)	(9.4)	(G 1/4)	(80.30)	(38.9)	(46.0)	(38.1)	(23.60)	(89.2)	(27.9)	(5.1)	(45.5)	(41.9)	(69.8)	(19.8)	(19.1)	(183.1)	(G 1/8)	(29.5)
NVPM20M0-***-S05A38	(Metric)	(G 1/8)	(G 1/4)	(G 1/4)	(5.1)	(9.4)	(G 1/4)	(80.3)	(38.9)	(46.0)	(38.1)	(23.6)	(89.2)	(27.9)	(5.1)	(45.5)	(41.9)	(69.8)	(19.8)	(19.1)	(195.1)	(G 1/8)	(29.5)
NVPM20M0-***-S12A38	(Metric)	(G 1/8)	(G 1/4)	(G 1/4)	(5.1)	(9.4)	(G 1/4)	(80.3)	(38.9)	(46.0)	(38.1)	(23.6)	(89.2)	(27.90)	(5.1)	(45.50)	(41.9)	(69.8)	(19.8)	(19.1)	(223.3)	(G 1/8)	(29.5)



NVP20C

Air Saver

- » Energy efficient – compressed air on only when needed, automatic shut-off
- » High Productivity – non-clogging design reduces downtime
- » Strong hold – powerful vacuum up to 28"Hg [948mbar]
- » Mounts Easily – compact and lightweight
- » Fast Response – installs close to vacuum point
- » Efficient – minimal air consumption
- » Reliable operation – straight-through design with no moving parts

Technical Data

Fluid:
Filtered (100 Micron) unlubricated, non-corrosive dry gases

Operating Temperature
-30° to ~250° F (-34° to ~121°C)

Operating Pressure
80 PSI (5.5 bar) Standard or 60 PSI (4.1 bar)

Materials
Generator Body: Anodized Aluminum

Supply/Vacuum Line
1/4" OD for sizes 60 and 90
3/8" OD for sizes 100 and 150

Mounting Holes
Mounting holes accept 10-32 [M5] screws

Performance Level Designations
"M", "Y" 0-20"Hg [0 to 677mbar] for medium vacuum/high flow applications
"H", "Z" 0-28"Hg [0 to 948mbar] for high vacuum/standard flow applications

Generator Selection

1. Determine the desired evacuation time (speed)
2. Calculate the total volume of air to be evacuated in the system including vacuum lines, vessel/cavity size, cups, etc.
3. Determine the desired vacuum level, "Hg/mbar Application
ex.: Evacuate 2 cu.ft. of air in 1 minute (60 sec) at a vacuum level of 21"Hg
Formula: Time (60 sec)/Cu. ft (2) = 30 seconds per cu. ft. (evacuation speed)

Product options

Standard (NVP20)
Pneumatic blow-off (NVP2X)
Valve controlled blow-off (NVP20V)
Multi-port (NVP20M)
Air Saver (NVP20C)



Standard Models

Part number	Max. Vacuum Level	Max. Vacuum Flow	Air Consumption	Silencer
NVP20CO-60M-S02A38	20"Hg	0.50 SCFM	0.50 SCFM	NAA4 Silencer
NVP20CO-60H-S02A38	28"Hg	0.50 SCFM	0.80 SCFM	NAA4 Silencer
NVP20CO-90M-S02A38	20"Hg	1.40 SCFM	1.40 SCFM	NAA4 Silencer
NVP20CO-90H-S02A38	28"Hg	1.20 SCFM	1.80 SCFM	NAA4 Silencer
NVP20CO-100M-S02A38	20"Hg	2.10 SCFM	1.80 SCFM	NAA4 Silencer
NVP20CO-100H-S02A38	28"Hg	2.00 SCFM	2.80 SCFM	NAA4 Silencer
NVP20CO-150M-S02A38	20"Hg	3.50 SCFM	2.80 SCFM	NAA4 Silencer
NVP20CO-150H-S02A38	28"Hg	3.80 SCFM	4.80 SCFM	NAA4 Silencer

Accessories

Option selector

NVP 20CO- -S A38

Series	Substitute	Accessories	Substitute
NVP (Imperial Thread)		Extra Ports / NVG-150-GF	A38
NVPM (Metric Thread)	M		
Vacuum Flow Level	Substitute	Silencers	Substitute
Venturi Cartridge 60	60	None	S00
Venturi Cartridge 90	90	NAA4 (62dB)	S02
Venturi Cartridge 100	100	NST4 (62dB)	S05
Venturi Cartridge 150	150		
Vacuum Level	Substitute		
20"Hg @ 80PSI (Standard)	M		
28"Hg @ 80PSI (Standard)	H		
20"Hg @ 60PSI	Y		
28"Hg @ 60PSI	Z		



Dimensions inches (mm)

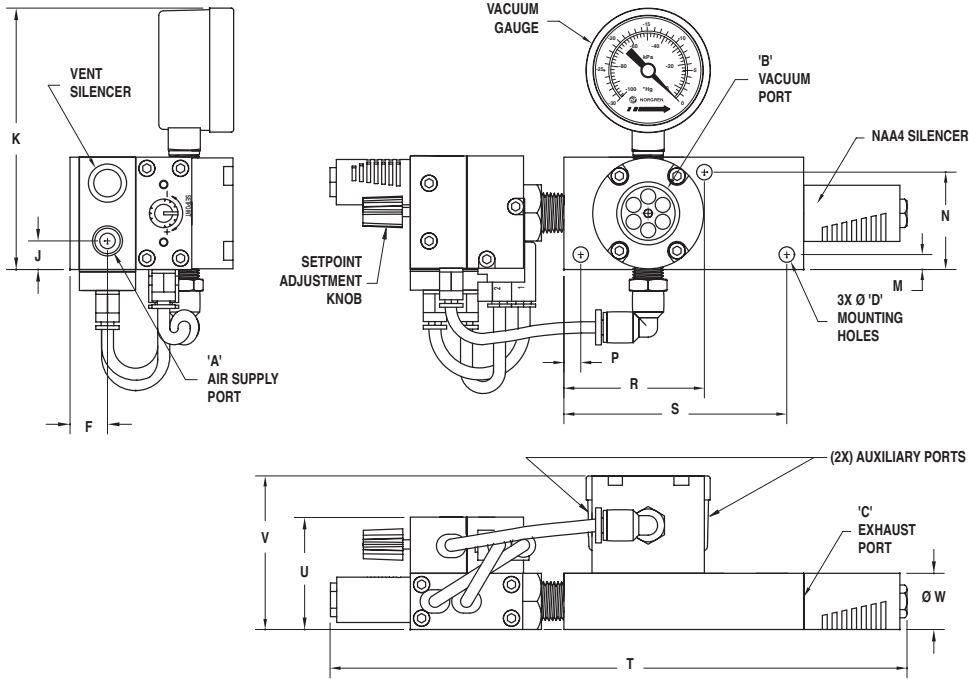

Models	Units	A	B	C	D	E	F	J	K	M	N	P	R	S	T	U	V	W
NVP20CO-***-S02A38	Imperial	1/8 NPTF	1/2 NPTF	1/4 NPTF	0.21	1/8 NPTF	0.375	0.34	3.87	0.20	1.30	0.23	1.88	2.95	7.53	1.47	2.20	0.75
NVPM20CO-***-S02A38	(Metric)	(G 1/8)	(G 1/2)	(G 1/4)	(5.2)	(G 1/8)	(9.5)	(8.6)	(98.3)	(5.1)	(33.0)	(5.7)	(47.6)	(74.9)	(191.3)	(37.3)	(55.9)	(19.1)

NVP20, NVP20V, NVP2X, NVP20M, AND NVP20C



Performance Data

Model	Air Consumption SCFM (L/min)	Vacuum Level "Hg (mbar)	0"Hg (0)	3"Hg (102)	6"Hg (203)	9"Hg (305)	10"Hg (339)	12"Hg (406)	15"Hg (508)	18"Hg (609)	20"Hg (677)	21"Hg (711)	24"Hg (813)	27"Hg (914)	28"Hg (948)
90L	0.50 (14.2)	Vacuum Flow SCFM (L/min)	1.30 (36.8)	1.10 (31.1)	0.70 (19.8)	0.20 (5.7)	0.00 (0.0)	- (-)	- (-)	- (-)	- (-)	- (-)	- (-)	- (-)	- (-)
		Evacuation time (seconds)	0.00 (0.0)	3.26 (0.1)	7.93 (0.3)	18.65 (0.7)	39.63 (1.4)	- (-)	- (-)	- (-)	- (-)	- (-)	- (-)	- (-)	- (-)
100L	1.40 (39.6)	Vacuum Flow SCFM (L/min)	2.10 (59.5)	1.60 (45.3)	1.10 (31.1)	0.50 (14.2)	0.00 (0.0)	- (-)	- (-)	- (-)	- (-)	- (-)	- (-)	- (-)	- (-)
		Evacuation time (seconds)	0.00 (0.0)	2.33 (0.1)	4.66 (0.2)	10.88 (0.4)	24.00 (0.9)	- (-)	- (-)	- (-)	- (-)	- (-)	- (-)	- (-)	- (-)
150L	1.80 (51.0)	Vacuum Flow SCFM (L/min)	3.50 (99.1)	2.50 (70.8)	1.90 (53.8)	0.70 (19.8)	0.00 (0.0)	- (-)	- (-)	- (-)	- (-)	- (-)	- (-)	- (-)	- (-)
		Evacuation time (seconds)	0.00 (0.0)	1.54 (0.1)	4.36 (0.2)	10.77 (0.4)	22.83 (0.8)	- (-)	- (-)	- (-)	- (-)	- (-)	- (-)	- (-)	- (-)
60M	0.50 (14.2)	Vacuum Flow SCFM (L/min)	0.50 (14.2)	0.40 (11.3)	0.30 (8.5)	0.22 (6.2)	- (-)	0.15 (4.2)	0.08 (2.3)	0.03 (0.8)	0.00 (0.0)	- (-)	- (-)	- (-)	- (-)
		Evacuation time (seconds)	0.00 (0.0)	12.50 (0.4)	25.10 (0.9)	43.90 (1.6)	- (-)	68.60 (2.4)	99.30 (3.5)	153.70 (5.4)	227.00 (8.0)	- (-)	- (-)	- (-)	- (-)
90M	1.40 (39.6)	Vacuum Flow SCFM (L/min)	1.40 (39.6)	1.25 (35.4)	1.20 (34.0)	1.05 (29.7)	- (-)	0.85 (24.1)	0.65 (18.4)	0.25 (7.1)	0.00 (0.0)	- (-)	- (-)	- (-)	- (-)
		Evacuation time (seconds)	0.00 (0.0)	3.75 (0.1)	7.20 (0.3)	12.40 (0.4)	- (-)	19.10 (0.7)	29.90 (1.1)	52.00 (1.8)	104.00 (3.7)	- (-)	- (-)	- (-)	- (-)
100M	1.80 (51.0)	Vacuum Flow SCFM (L/min)	2.10 (59.5)	2.00 (56.6)	1.85 (52.4)	1.75 (49.6)	- (-)	1.60 (45.3)	1.25 (35.4)	0.80 (22.7)	0.00 (0.0)	- (-)	- (-)	- (-)	- (-)
		Evacuation time (seconds)	0.00 (0.0)	2.65 (0.1)	5.80 (0.2)	9.90 (0.3)	- (-)	16.20 (0.6)	22.90 (0.8)	36.20 (1.3)	56.60 (2.0)	- (-)	- (-)	- (-)	- (-)
150M	2.80 (79.3)	Vacuum Flow SCFM (L/min)	3.50 (99.1)	3.20 (90.6)	2.95 (83.5)	2.75 (77.9)	- (-)	2.50 (70.8)	1.80 (51.0)	0.95 (26.9)	0.00 (0.0)	- (-)	- (-)	- (-)	- (-)
		Evacuation time (seconds)	0.00 (0.0)	1.35 (0.0)	3.20 (0.1)	5.20 (0.2)	- (-)	7.70 (0.3)	11.80 (0.4)	23.40 (0.8)	52.00 (1.8)	- (-)	- (-)	- (-)	- (-)
60H	0.80 (22.7)	Vacuum Flow SCFM (L/min)	0.50 (14.2)	0.38 (10.8)	0.32 (9.1)	0.30 (8.5)	- (-)	0.27 (7.6)	0.23 (6.5)	0.20 (5.7)	- (-)	0.13 (3.7)	0.05 (1.4)	0.02 (0.6)	0.00 (0.0)
		Evacuation time (seconds)	0.00 (0.0)	15.00 (0.5)	29.80 (1.1)	50.60 (1.8)	- (-)	74.50 (2.6)	102.80 (3.6)	135.90 (4.8)	- (-)	183.20 (6.5)	245.90 (8.7)	410.20 (14.5)	790.80 (27.9)
90H	1.80 (51.0)	Vacuum Flow SCFM (L/min)	1.20 (34.0)	1.00 (28.3)	0.95 (26.9)	0.90 (25.5)	- (-)	0.85 (24.1)	0.75 (21.2)	0.70 (19.8)	- (-)	0.52 (14.7)	0.47 (13.3)	0.20 (5.7)	0.00 (0.0)
		Evacuation time (seconds)	0.00 (0.0)	6.50 (0.2)	12.30 (0.4)	18.90 (0.7)	- (-)	32.50 (1.1)	47.00 (1.7)	65.40 (2.3)	- (-)	92.20 (3.3)	130.00 (4.6)	222.20 (7.8)	281.30 (9.9)
100H	2.80 (79.3)	Vacuum Flow SCFM (L/min)	2.00 (56.6)	1.85 (52.4)	1.75 (49.6)	1.57 (44.5)	- (-)	1.40 (39.6)	1.25 (35.4)	1.05 (29.7)	- (-)	0.84 (23.8)	0.70 (19.8)	0.35 (9.9)	0.00 (0.0)
		Evacuation time (seconds)	0.00 (0.0)	2.70 (0.1)	6.50 (0.2)	11.20 (0.4)	- (-)	17.50 (0.6)	25.80 (0.9)	38.40 (1.4)	- (-)	55.20 (1.9)	79.20 (2.8)	166.70 (5.9)	251.80 (8.9)
150H	4.80 (135.9)	Vacuum Flow SCFM (L/min)	3.20 (90.6)	2.80 (79.3)	2.50 (70.8)	2.30 (65.1)	- (-)	2.00 (56.6)	1.60 (45.3)	1.40 (39.6)	- (-)	1.20 (34.0)	0.80 (22.7)	0.50 (14.2)	0.00 (0.0)
		Evacuation time (seconds)	0.00 (0.0)	2.30 (0.1)	3.80 (0.1)	6.50 (0.2)	- (-)	10.20 (0.4)	14.20 (0.5)	21.30 (0.8)	- (-)	44.90 (1.6)	55.00 (1.9)	81.00 (2.9)	125.00 (4.4)

Evacuation time in seconds based on 1 cubic foot volume / "Hg (1 Liter Volume / mbar)



Performance Data

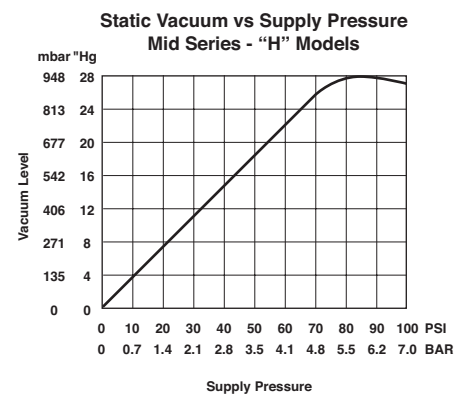
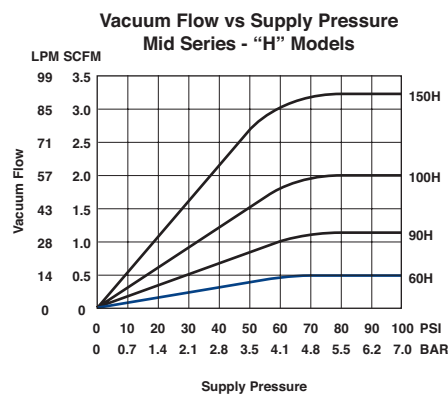
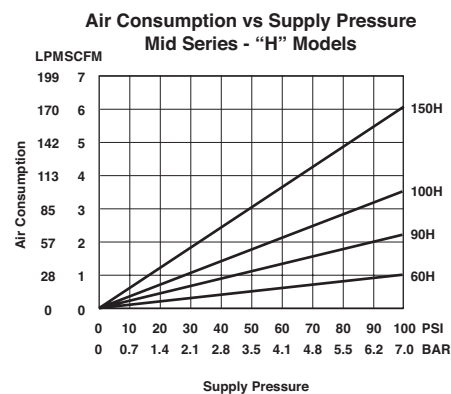
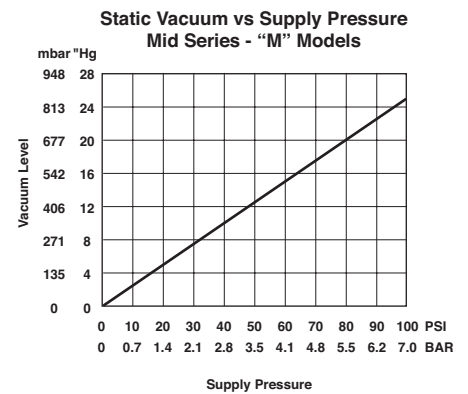
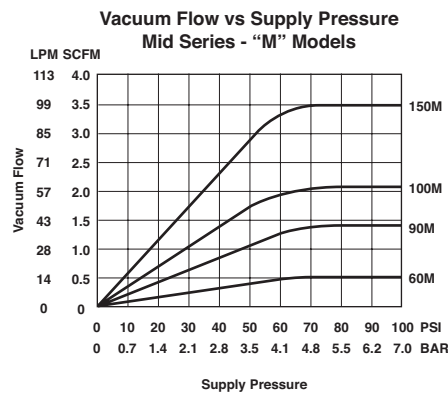
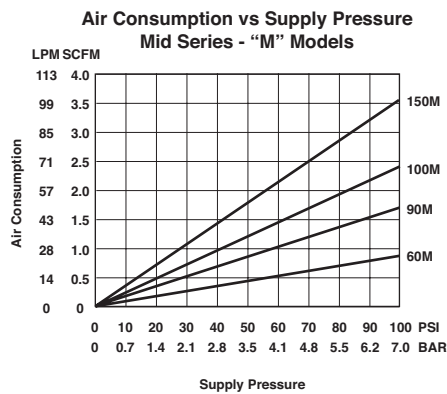
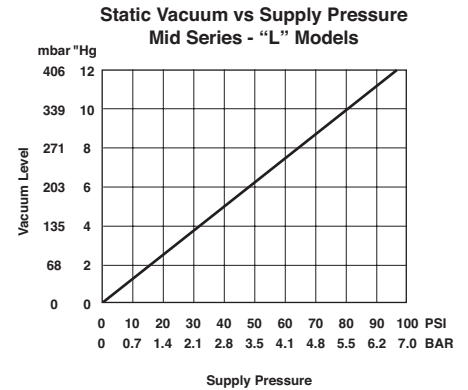
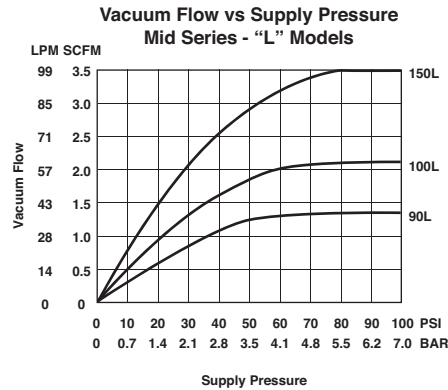
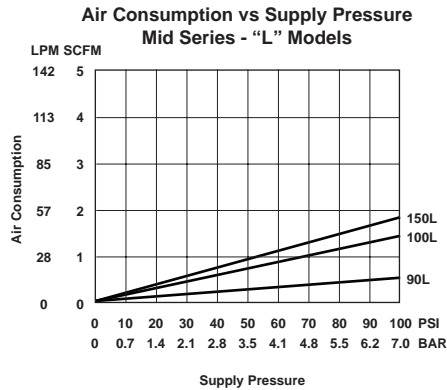

Notes: Standard operating pressure for Norgren generators is 80 PSI [5.5 bar]. Generators can be factory modified to run at other operating pressures i.e. 60 PSI [4.1 bar] etc. The values shown in the performance chart will remain the same for all operating pressures.

Warnings

Improper selection, misuse, age or malfunction of components used in systems can cause failure in various modes. The system designer is warned to consider the failure modes of all component parts and to provide adequate safeguards to prevent personal injury or damage to equipment or property in the event of such failure modes. System designers and end users are cautioned to consult instruction sheets and specifications available from the factory. The system designer/end user is responsible for verifying that all requirements for the application are met.

Warranty

The products described herein are warranted subject to seller's Standard Terms and Condition of Sale, available at seller's website.

NVP50



- » Integral check valve and air pilot controlled blowoff for rapid part release or vacuum line clean out
- » High Productivity – non-clogging design reduces downtime
- » Strong hold – powerful vacuum up to 28"Hg [948mbar]
- » Mounts Easily – compact and lightweight
- » Fast Response – installs close to vacuum point
- » Efficient – minimal air consumption
- » Reliable operation – straight-through design with no moving parts

Technical Data

Fluid
Filtered (50 Micron) unlubricated, non-corrosive dry gases

Operating Temperature
-23° to -122° F (-5° to -50°C)

Operating Pressure
80 PSI (5.5 bar)

Materials
Generator Body: Anodized Aluminum

Supply Line
1/4" OD (6mm) tube recommended

Vacuum Line
3/8" OD (10mm) tube recommended

Pilot Line
5/32" OD (4mm) tube recommended

Mounting Holes
0.201" diameter

Performance Level

Designations
"L", "X" 0-10"Hg [0 to 339mbar] for low vacuum/high flow applications
"M", "Y" 0-20"Hg [0 to 677mbar] for medium vacuum/high flow applications
"H", "Z" 0-28"Hg [0 to 948mbar] for high vacuum/standard flow applications

Models
There are three versions of the NVP50 Series available:
NVP50 – Air pilot vacuum control and blow-off.
NVP50C0 – Integrated air saver circuit, for reduced air consumption and pilot controlled blow-off.
NVP50C1 – Air pilot controlled vacuum with integrated air saver circuit, and pilot controlled blow-off. The NVP50-ASP, also, has a pneumatic signal output for vacuum setpoint notification.



NVP50



NVP50C0



NVP50C1

Standard Models

Part number	Max. Vacuum Level	Max. Vacuum Flow	Air Consumption	Silencer
NVP50-90M-S05A00	20"Hg	1.40 SCFM	1.40 SCFM	NST4 Silencer
NVP50-90H-S05A00	28"Hg	1.20 SCFM	1.80 SCFM	NST4 Silencer
NVP50-100M-S05A00	20"Hg	2.10 SCFM	1.80 SCFM	NST4 Silencer
NVP50-100H-S05A00	28"Hg	2.00 SCFM	2.80 SCFM	NST4 Silencer
NVP50-150M-S05A00	20"Hg	3.50 SCFM	2.80 SCFM	NST4 Silencer
NVP50-150H-S05A00	28"Hg	3.20 SCFM	4.80 SCFM	NST4 Silencer

Accessories

Option selector

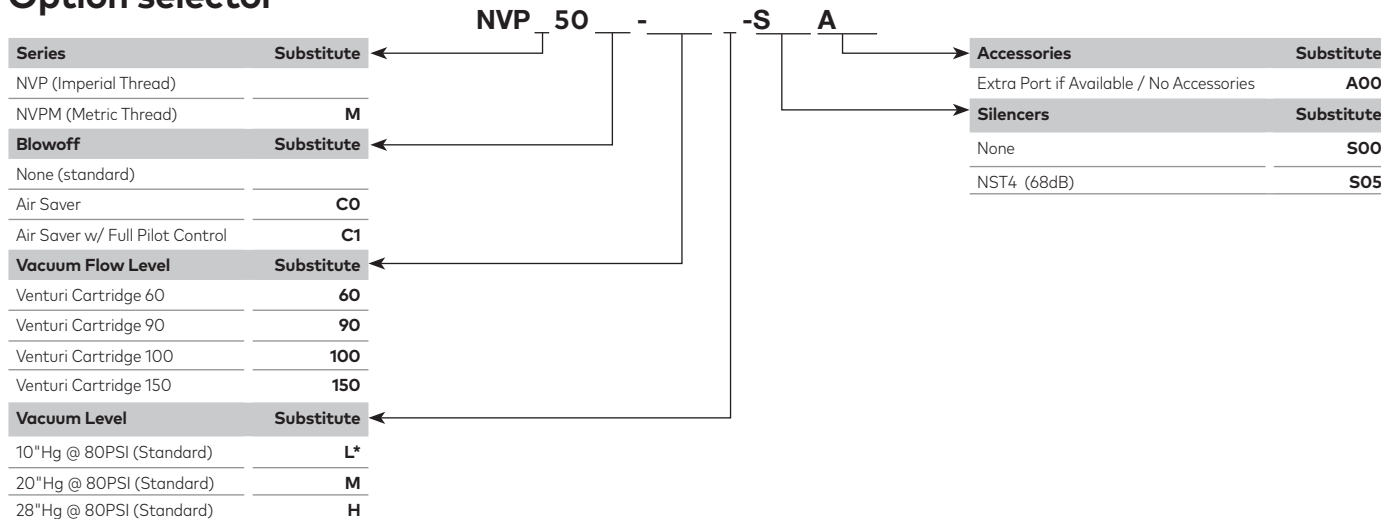

* Not available in 60 series



Accessories

Model	Inline Fitting	Swivel Elbow	Vacuum Fitting	Bellows Cup	Flat Cup	Spring Leveler
NVP50-90M-S05A00	124250428	124470428	NVCF45-14M	NBG*****	NFG*****	NVSL3-***
NVP50-90H-S05A00	124250428	124470428	NVCF45-14M	NBG*****	NFG*****	NVSL3-***
NVP50-100M-S05A00	124250628	124470628	NVCF45-14M	NBG*****	NFG*****	NVSL3-***
NVP50-100H-S05A00	124250628	124470628	NVCF45-14M	NBG*****	NFG*****	NVSL3-***
NVP50-150M-S05A00	124250628	124470628	NVCF45-14M	NBG*****	NFG*****	NVSL3-***
NVP50-150H-S05A00	124250628	124470628	NVCF45-14M	NBG*****	NFG*****	NVSL3-***

*Proper selection of vacuum cups depends on the application. Cups are available in various durometers, colors and materials. If you do not see what you are looking for, please consult factory
 *The fittings, cups, and spring levelers listed are a small selection of possible options please refer to the specific catalog section

Dimensions inches (mm)

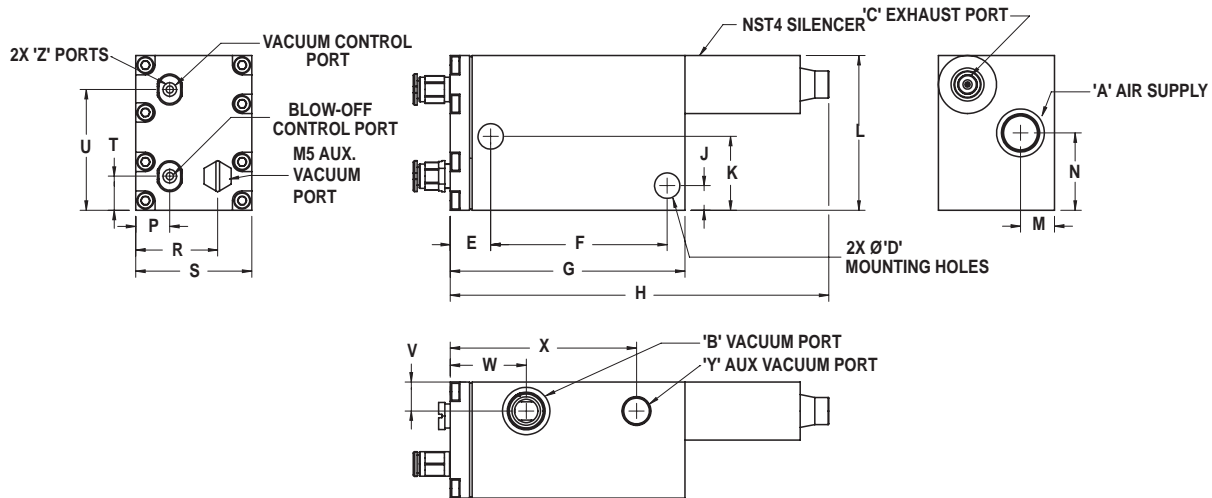

Model	Units	A	B	C	D	E	F	G	H	J	K	L	M	N	P	R	S	T	U	V	W	X	Y	Z
NVP50-****-S05A00	Imperial	1/4 NPTF	1/4 NPTF	1/4 NPTF	0.21	0.52	2.28	3.03	4.89	0.25	0.95	2.00	0.44	1.00	0.44	1.06	1.50	0.44	1.56	0.38	0.98	2.41	1/8 NPTF	5/32
NVPM50-****-S05A00	(Metric)	(G) 1/4	(G) 1/4	(G) 1/4	(5.3)	(13.2)	(57.9)	(77.0)	(124.2)	(6.4)	(24.2)	(50.8)	(11.2)	(25.4)	(11.2)	(26.9)	(38.1)	(11.2)	(39.6)	(9.7)	(24.9)	(61.1)	(G) 1/8	(M3)

Dimensions inches (mm)

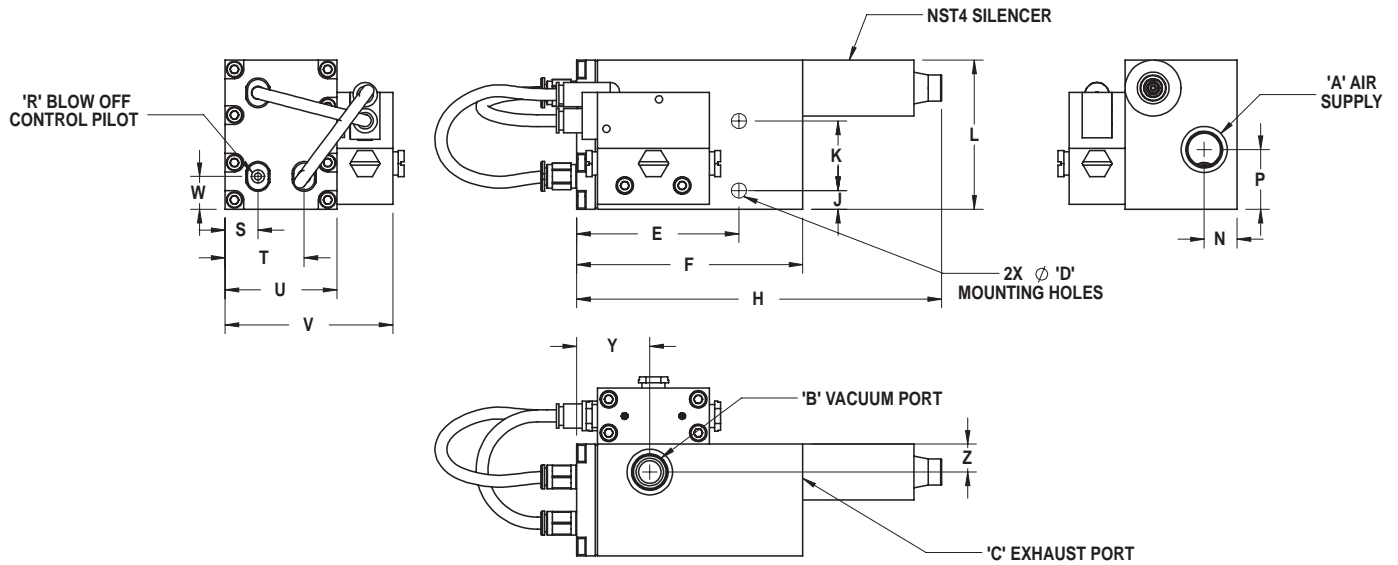

Models	Units	A	B	C	D	E	F	H	J	K	L	N	P	R	S	T	U	V	W	Y	Z
NVP50CO-****-S05A00	Imperial	1/4 NPTF	1/4 NPTF	1/4 NPTF	0.21	2.18	3.03	4.89	0.25	0.93	2.00	0.44	0.72	5/32	0.44	1.06	1.50	2.25	0.44	0.98	0.38
NVPM50CO-****-S05A00	(Metric)	(G 1/4)	(G 1/4)	(G 1/4)	(5.3)	(55.4)	(77.0)	(124.2)	(6.4)	(23.6)	(50.8)	(11.9)	(18.3)	M3	(11.2)	(26.9)	(38.1)	(57.2)	(11.2)	(24.9)	(9.5)

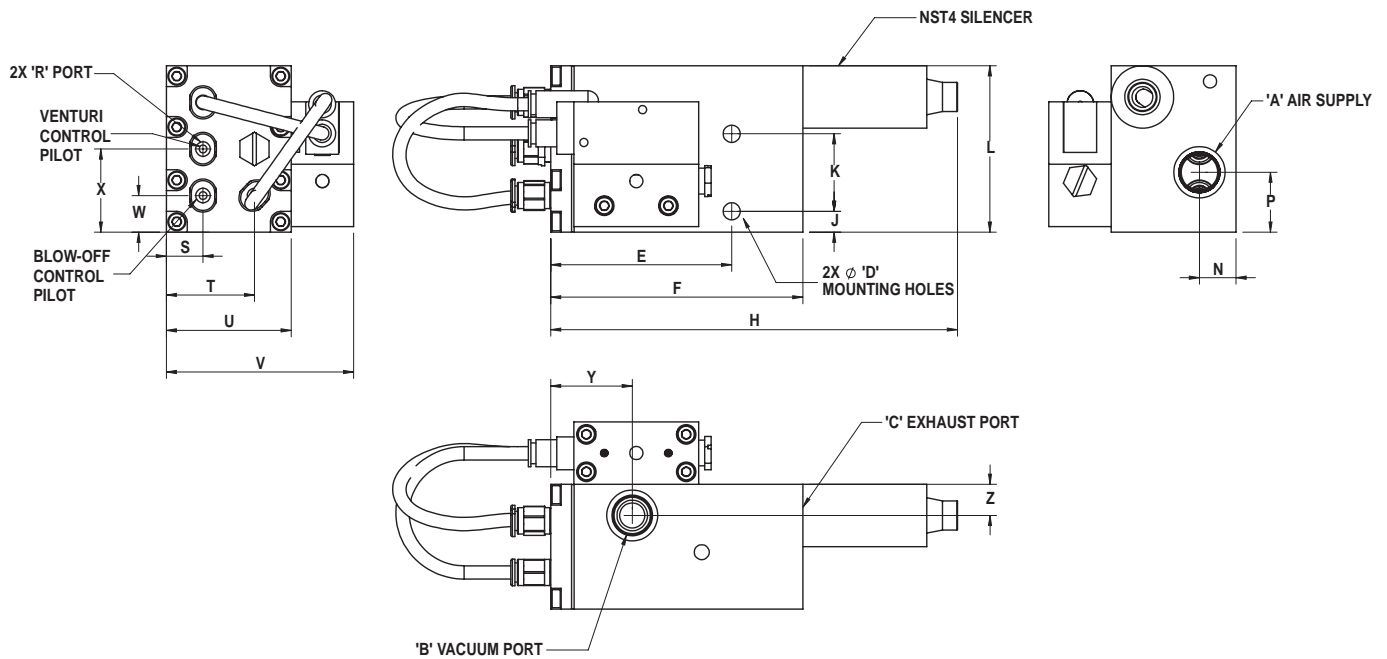

Model	Units	A	B	C	D	E	F	H	J	K	L	N	P	R	S	T	U	V	W	X	Y	Z
NVP50C1-****-S05A00	Imperial	1/4 NPTF	1/4 NPTF	1/4 NPTF	0.21	2.18	3.03	4.89	0.25	0.93	2.00	0.44	0.72	5/32	0.44	1.06	1.50	2.25	0.44	1.00	0.98	0.38
NVPM50C1-****-S05A00	(Metric)	(G 1/4)	(G 1/4)	(G 1/4)	(5.3)	(55.4)	(77.0)	(124.2)	(6.4)	(23.6)	(50.8)	(11.2)	(18.3)	(M3)	(11.2)	(26.9)	(38.1)	(57.2)	(11.2)	(25.4)	(24.9)	(9.5)



Performance Data

Model	Air Consumption SCFM (L/min)	Vacuum Level "Hg (mbar)	0"Hg (0)	3"Hg (102)	6"Hg (203)	9"Hg (305)	10"Hg (339)	12"Hg (406)	15"Hg (508)	18"Hg (609)	20"Hg (677)	21"Hg (711)	24"Hg (813)	27"Hg (914)	28"Hg (948)
90L	0.50 (14.2)	Vacuum Flow SCFM (L/min)	1.30 (36.8)	1.10 (31.1)	0.70 (19.8)	0.20 (5.7)	0.00 (0.0)	- (-)	- (-)	- (-)	- (-)	- (-)	- (-)	- (-)	- (-)
		Evacuation time (seconds)	0.00 (0.0)	3.26 (0.1)	7.93 (0.3)	18.65 (0.7)	39.63 (1.4)	- (-)	- (-)	- (-)	- (-)	- (-)	- (-)	- (-)	- (-)
100L	1.40 (39.6)	Vacuum Flow SCFM (L/min)	2.10 (59.5)	1.60 (45.3)	1.10 (31.1)	0.50 (14.2)	0.00 (0.0)	- (-)	- (-)	- (-)	- (-)	- (-)	- (-)	- (-)	- (-)
		Evacuation time (seconds)	0.00 (0.0)	2.33 (0.1)	4.66 (0.2)	10.88 (0.4)	24.00 (0.9)	- (-)	- (-)	- (-)	- (-)	- (-)	- (-)	- (-)	- (-)
150L	1.80 (51.0)	Vacuum Flow SCFM (L/min)	3.50 (99.1)	2.50 (70.8)	1.90 (53.8)	0.70 (19.8)	0.00 (0.0)	- (-)	- (-)	- (-)	- (-)	- (-)	- (-)	- (-)	- (-)
		Evacuation time (seconds)	0.00 (0.0)	1.54 (0.1)	4.36 (0.2)	10.77 (0.4)	22.83 (0.8)	- (-)	- (-)	- (-)	- (-)	- (-)	- (-)	- (-)	- (-)
60M	0.50 (14.2)	Vacuum Flow SCFM (L/min)	0.50 (14.2)	0.40 (11.3)	0.30 (8.5)	0.22 (6.2)	- (-)	0.15 (4.2)	0.08 (2.3)	0.03 (0.8)	0.00 (0.0)	- (-)	- (-)	- (-)	- (-)
		Evacuation time (seconds)	0.00 (0.0)	12.50 (0.4)	25.10 (0.9)	43.90 (1.6)	- (-)	68.60 (2.4)	99.30 (3.5)	153.70 (5.4)	227.00 (8.0)	- (-)	- (-)	- (-)	- (-)
90M	1.40 (39.6)	Vacuum Flow SCFM (L/min)	1.40 (39.6)	1.25 (35.4)	1.20 (34.0)	1.05 (29.7)	- (-)	0.85 (24.1)	0.65 (18.4)	0.25 (7.1)	0.00 (0.0)	- (-)	- (-)	- (-)	- (-)
		Evacuation time (seconds)	0.00 (0.0)	3.75 (0.1)	7.20 (0.3)	12.40 (0.4)	- (-)	19.10 (0.7)	29.90 (1.1)	52.00 (1.8)	104.00 (3.7)	- (-)	- (-)	- (-)	- (-)
100M	1.80 (51.0)	Vacuum Flow SCFM (L/min)	2.10 (59.50)	2.00 (56.60)	1.85 (52.40)	1.75 (49.60)	- (-)	1.60 (45.30)	1.25 (35.40)	0.80 (22.70)	0.00 (0.00)	- (-)	- (-)	- (-)	- (-)
		Evacuation time (seconds)	0.00 (0.0)	2.65 (0.1)	5.80 (0.2)	9.90 (0.3)	- (-)	16.20 (0.6)	22.90 (0.8)	36.20 (1.3)	56.60 (2.0)	- (-)	- (-)	- (-)	- (-)
150M	2.80 (79.3)	Vacuum Flow SCFM (L/min)	3.50 (99.1)	3.20 (90.6)	2.95 (83.5)	2.75 (77.9)	- (-)	2.50 (70.8)	1.80 (51.0)	0.95 (26.9)	0.00 (0.0)	- (-)	- (-)	- (-)	- (-)
		Evacuation time (seconds)	0.00 (0.0)	1.35 (0.0)	3.20 (0.1)	5.20 (0.2)	- (-)	7.70 (0.3)	11.80 (0.4)	23.40 (0.8)	52.00 (1.8)	- (-)	- (-)	- (-)	- (-)
60H	0.80 (22.7)	Vacuum Flow SCFM (L/min)	0.50 (14.2)	0.38 (10.8)	0.32 (9.1)	0.30 (8.5)	- (-)	0.27 (7.6)	0.23 (6.5)	0.20 (5.7)	- (-)	0.13 (3.7)	0.05 (1.4)	0.02 (0.6)	0.00 (0.0)
		Evacuation time (seconds)	0.00 (0.0)	15.00 (0.5)	29.80 (1.1)	50.60 (1.8)	- (-)	74.50 (2.6)	102.80 (3.6)	135.90 (4.8)	- (-)	183.20 (6.5)	245.90 (8.7)	410.20 (14.5)	790.80 (27.9)
90H	1.80 (51.0)	Vacuum Flow SCFM (L/min)	1.20 (34.0)	1.00 (28.3)	0.95 (26.9)	0.90 (25.5)	- (-)	0.85 (24.1)	0.75 (21.2)	0.70 (19.8)	- (-)	0.52 (14.7)	0.47 (13.3)	0.20 (5.7)	0.00 (0.0)
		Evacuation time (seconds)	0.00 (0.0)	6.50 (0.2)	12.30 (0.4)	18.90 (0.7)	- (-)	32.50 (1.1)	47.00 (1.7)	65.40 (2.3)	- (-)	92.20 (3.3)	130.00 (4.6)	222.20 (7.8)	281.30 (9.9)
100H	2.80 (79.3)	Vacuum Flow SCFM (L/min)	2.00 (56.6)	1.85 (52.4)	1.75 (49.6)	1.57 (44.5)	- (-)	1.40 (39.6)	1.25 (35.4)	1.05 (29.7)	- (-)	0.84 (23.8)	0.70 (19.8)	0.35 (9.9)	0.00 (0.0)
		Evacuation time (seconds)	0.00 (0.0)	2.70 (0.1)	6.50 (0.2)	11.20 (0.4)	- (-)	17.50 (0.6)	25.80 (0.9)	38.40 (1.4)	- (-)	55.20 (1.9)	79.20 (2.8)	166.70 (5.9)	251.80 (8.9)
150H	4.80 (135.9)	Vacuum Flow SCFM (L/min)	3.20 (90.6)	2.80 (79.3)	2.50 (70.8)	2.30 (65.1)	- (-)	2.00 (56.6)	1.60 (45.3)	1.40 (39.6)	- (-)	1.20 (34.0)	0.80 (22.7)	0.50 (14.2)	0.00 (0.0)
		Evacuation time (seconds)	0.00 (0.0)	2.30 (0.1)	3.80 (0.1)	6.50 (0.2)	- (-)	10.20 (0.4)	14.20 (0.5)	21.30 (0.8)	- (-)	44.90 (1.6)	55.00 (1.9)	81.00 (2.9)	125.00 (4.4)

Evacuation time in seconds based on 1 cubic foot volume / "Hg (1 Liter Volume / mbar)

Performance Data

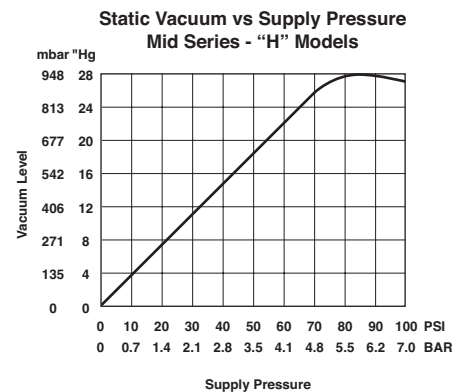
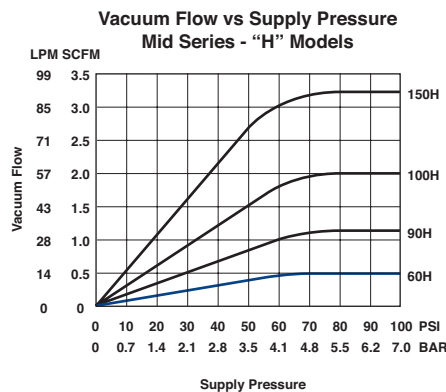
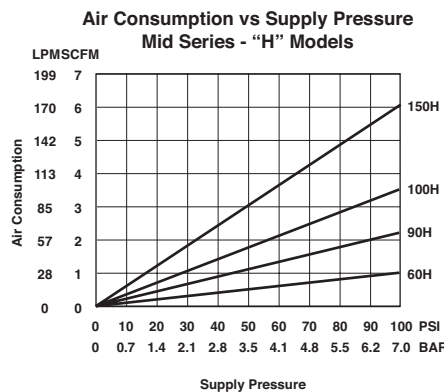
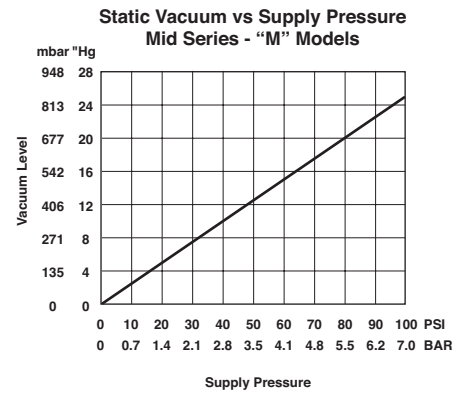
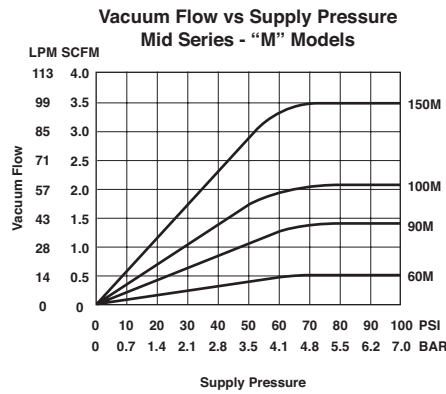
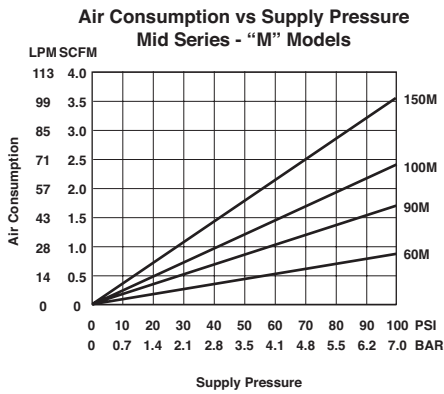
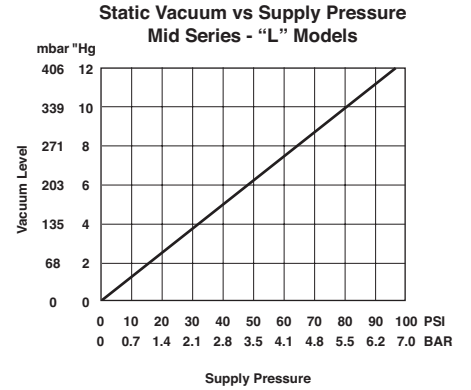
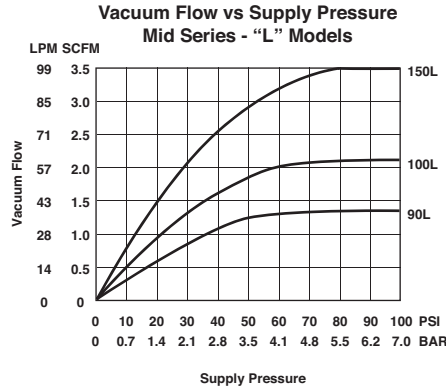
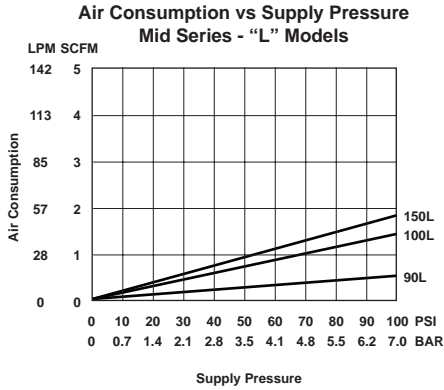

Notes: Standard operating pressure for Norgren generators is 80 PSI [5.5 bar]. Generators can be factory modified to run at other operating pressures i.e. 60 PSI [4.1 bar] etc. The values shown in the performance chart will remain the same for all operating pressures.

Warnings

Improper selection, misuse, age or malfunction of components used in systems can cause failure in various modes. The system designer is warned to consider the failure modes of all component parts and to provide adequate safeguards to prevent personal injury or damage to equipment or property in the event of such failure modes. System designers and end users are cautioned to consult instruction sheets and specifications available from the factory. The system designer/end user is responsible for verifying that all requirements for the application are met.

Warranty

The products described herein are warranted subject to seller's Standard Terms and Condition of Sale, available at seller's website.



- » High Productivity – non-clogging design reduces downtime
- » Strong hold – powerful vacuum up to 28"Hg [948mbar]
- » Mounts Easily – compact and lightweight
- » Fast Response – installs close to vacuum point
- » Efficient – minimal air consumption
- » Reliable operation – straight-through design with no moving parts

Technical Data

Fluid

Filtered (100 Micron) unlubricated, non-corrosive dry gases

Operating Temperature

-100° to -400° F (-73° to -204°C)

Operating Pressure

80 PSI (5.5 bar) Standard or 60 PSI (4.1 bar)

Materials

Generator Body: Anodized Aluminum

Supply Line

3/8" OD (10mm)

Vacuum Line

3/8" OD (10mm)

Mounting Holes

Mounting holes accept 10-32[M5] screws

Control Valve

3 way/2 position (faster part release), minimum orifice – 0.125" [3mm]

Performance Level Designations

"L", "X" 0-10"Hg [0 to 339mbar] for low vacuum/high flow applications

"M", "Y" 0-20"Hg [0 to 677mbar] for medium vacuum/high flow applications

"H", "Z" 0-28"Hg [0 to 948mbar] for high vacuum/standard flow applications

"M", "Y" 0-20"Hg [0 to 677mbar] for medium vacuum/high flow applications

Product options

Standard (NVP80)

Pneumatic blow-off (NVP8X)

Multi-port (NVP80M)

Air Saver (NVP80C)



Standard Models

Part number	Max. Vacuum Level	Max. Vacuum Flow	Air Consumption	Silencer
NVP80-200M-S08A00	20"Hg	6.00 SCFM	4.80 SCFM	NST6A Silencer
NVP80-200H-S08A00	28"Hg	5.40 SCFM	7.80 SCFM	NST6A Silencer
NVP80-250M-S10A00	20"Hg	9.50 SCFM	7.80 SCFM	NST8A Silencer
NVP80-250H-S10A00	28"Hg	9.00 SCFM	12.50 SCFM	NST8A Silencer

Accessories

Option selector

Series	Substitute	Accessories	Substitute
NVP (Imperial Thread)		Extra Ports / No Accessories	A00
NVPM (Metric Thread)	M	Extra Ports / NVG-150-GF	A38
Vacuum Flow Level	Substitute	Silencers (for NVP*80-200*)	Substitute
Venturi Cartridge 200	200	None	S00
Venturi Cartridge 250	250	NAA6 (70dB)	S03
		NST6A (72dB)	S08
		NSTAA6 (64dB)	S13
		NFA-51-375 (72dB)	S26
Vacuum Level	Substitute	Silencers (for NVP*80-250*)	Substitute
10"Hg @ 80PSI (Standard)	L	None	S00
20"Hg @ 80PSI (Standard)	M	NFA-51-500 (72dB)	S27
28"Hg @ 80PSI (Standard)	H	NFA-51-500 - No Elbow (72dB)	S37
10"Hg @ 60PSI	X	NST8A (74dB)	S10
20"Hg @ 60PSI	Y	NST8B (76dB)	S11
28"Hg @ 60PSI	Z		

NVP 80- -S A

Accessories

Model	Inline Fitting	Swivel Elbow Fitting	Vacuum Fitting	Bellows Cup	Flat Cup
NVP80-200M-S08A00	124250628	124470618	NVCF5-38M NVCF27-38M	NSM045****	NUC*****
NVP80-200H-S08A00	124250628	124470618	NVCF5-38M NVCF27-38M	NSM045****	NUC*****
NVP80-250M-S10A00	124250628	124470618	NVCF5-38M NVCF27-38M	NSM045****	NUC*****
NVP80-250H-S10A00	124250628	124470618	NVCF5-38M NVCF27-38M	NSM045****	NUC*****

*Proper selection of vacuum cups depends on the application. Cups are available in various durometers, colors and materials. If you do not see what you are looking for, please consult factory
 *The fittings, cups, and spring levelers listed are a small selection of possible options please refer to the specific catalog section

Dimensions inches (mm)

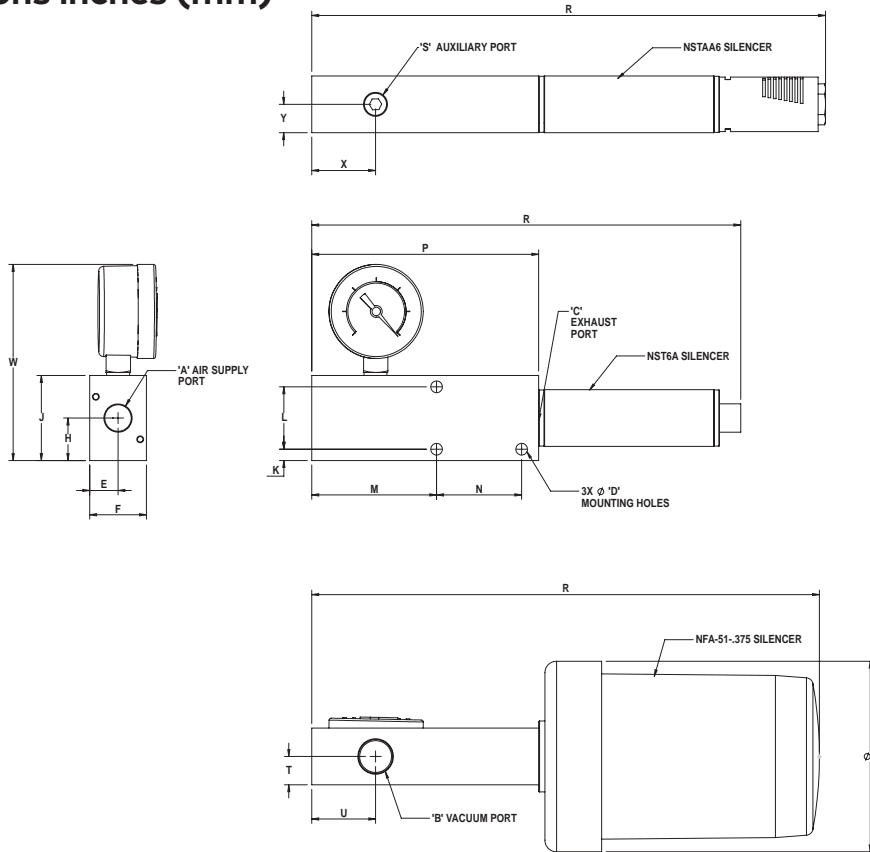

Model	Units	A	B	C	D	E	F	H	J	K	L	M	N	P	R	S	T	U	V	W	X	Y
NVP80-200*-S08A38	Imperial	1/4 NPTF	3/8 NPTF	3/8 NPTF	0.21	0.50	1.00	0.75	1.50	0.20	1.10	2.20	1.50	4.00	7.57	1/8 NPTF	0.50	1.13	3.36	3.46	1.12	0.50
NVP80-200*-S13A38	Imperial	1/4 NPTF	3/8 NPTF	3/8 NPTF	0.21	0.50	1.00	0.75	1.50	0.20	1.10	2.20	1.50	4.00	9.05	1/8 NPTF	0.50	1.13	3.36	3.46	1.12	0.50
NVP80-200*-S26A38	Imperial	1/4 NPTF	3/8 NPTF	3/8 NPTF	0.21	0.50	1.00	0.75	1.50	0.20	1.10	2.20	1.50	4.00	9.74	1/8 NPTF	0.50	1.13	3.36	3.46	1.12	0.50
NVPM80-200*-S08A38	(Metric)	(G 1/4)	(G 3/8)	(G 3/8)	(5.3)	(12.7)	(25.4)	(19.1)	(38.1)	(5.1)	(27.9)	(55.9)	(38.1)	(101.6)	(192.3)	G 1/8	(12.7)	(28.7)	(85.3)	(87.9)	(28.4)	(12.7)
NVPM80-200*-S13A38	(Metric)	(G 1/4)	(G 3/8)	(G 3/8)	(5.3)	(12.7)	(25.4)	(19.1)	(38.1)	(5.1)	(27.9)	(55.9)	(38.1)	(101.6)	(229.9)	G 1/8	(12.7)	(28.7)	(85.3)	(87.9)	(28.4)	(12.7)
NVPM80-200*-S26A38	(Metric)	(G 1/4)	(G 3/8)	(G 3/8)	(5.3)	(12.7)	(25.4)	(19.1)	(38.1)	(5.1)	(27.9)	(55.9)	(38.1)	(101.6)	(247.4)	G 1/8	(12.7)	(28.7)	(85.3)	(87.9)	(28.4)	(12.7)



Dimensions inches (mm)

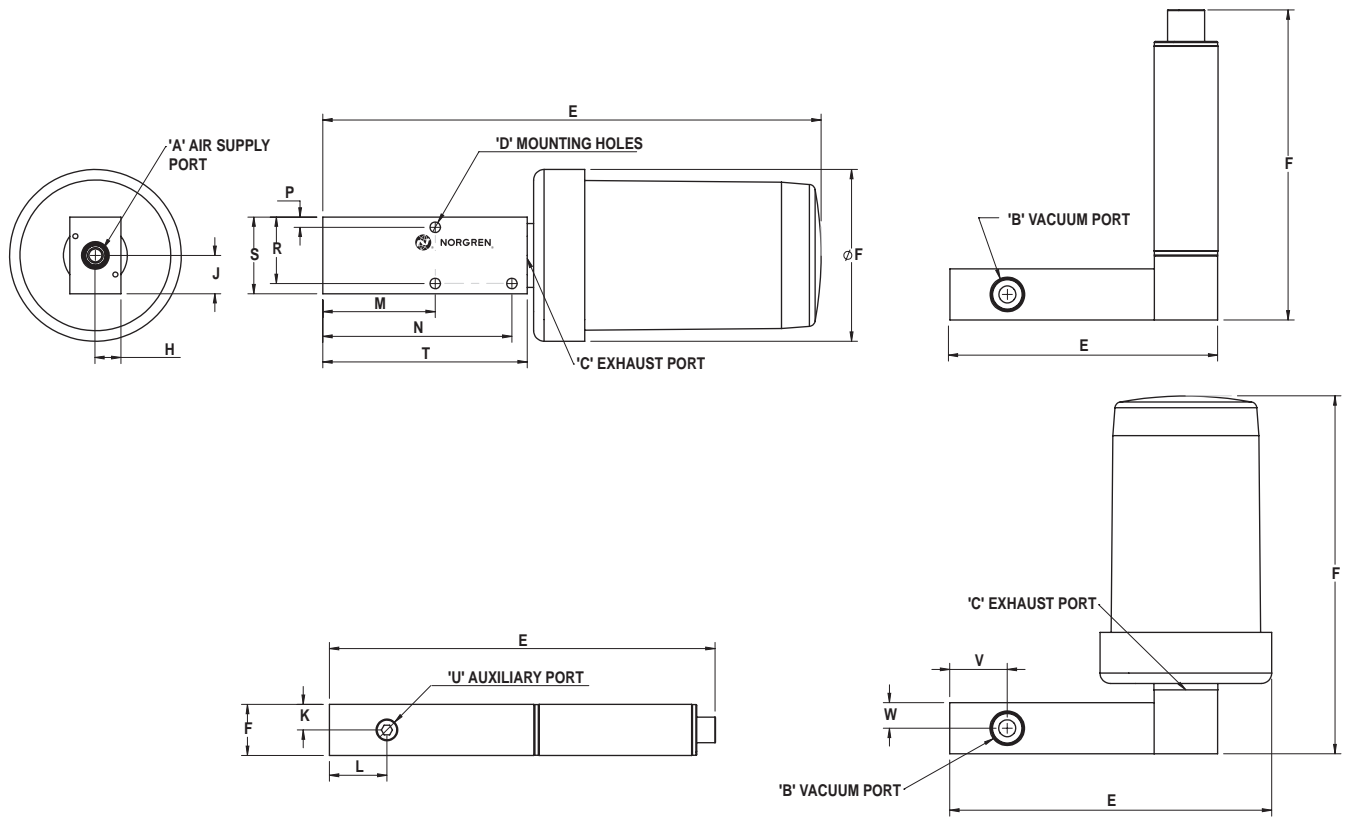

Model	Units	A	B	C	D	E	F	H	J	K	L	M	N	P	R	S	T	U	V	W
NVP80-250*-S27A00	Imperial	1/4 NPTF	3/8 NPTF	1/2 NPTF	0.21	6.30	7.00	0.50	0.75	0.50	1.13	2.20	3.70	0.20	1.30	1.50	4.00	1/8 NPTF	1.13	0.50
NVP80-250*-S37A00	Imperial	1/4 NPTF	3/8 NPTF	1/2 NPTF	0.21	9.75	3.36	0.50	0.75	0.50	1.13	2.20	3.70	0.20	1.30	1.50	4.00	1/8 NPTF	1.13	0.50
NVP80-250*-S10A00	Imperial	1/4 NPTF	3/8 NPTF	1/2 NPTF	0.21	7.54	1.00	0.50	0.75	0.50	1.13	2.20	3.70	0.20	1.30	1.50	4.00	1/8 NPTF	1.13	0.50
NVP80-250*-S11A00	Imperial	1/4 NPTF	3/8 NPTF	1/2 NPTF	0.21	5.24	6.06	0.50	0.75	0.50	1.13	2.20	3.70	0.20	1.30	1.50	4.00	1/8 NPTF	1.13	0.50
NVPM80-250*-S27A00	(Metric)	(G 1/4)	(G 3/8)	(G 1/2)	(5.3)	(160.0)	(177.9)	(12.7)	(19.1)	(12.7)	(28.6)	(55.9)	(94.0)	(5.1)	(33.0)	(38.1)	(101.6)	(G 1/8)	(28.6)	(12.7)
NVPM80-250*-S37A00	(Metric)	(G 1/4)	(G 3/8)	(G 1/2)	(5.3)	(247.7)	(85.3)	(12.7)	(19.1)	(12.7)	(28.6)	(55.9)	(94.0)	(5.1)	(33.0)	(38.1)	(101.6)	(G 1/8)	(28.6)	(12.7)
NVPM80-250*-S10A00	(Metric)	(G 1/4)	(G 3/8)	(G 1/2)	(5.3)	(191.5)	(25.4)	(12.7)	(19.1)	(12.7)	(28.6)	(55.9)	(94.0)	(5.1)	(33.0)	(38.1)	(101.6)	(G 1/8)	(28.6)	(12.7)
NVPM80-250*-S11A00	(Metric)	(G 1/4)	(G 3/8)	(G 1/2)	(5.3)	(133.1)	(153.9)	(12.7)	(19.1)	(12.7)	(28.6)	(55.9)	(94.0)	(5.1)	(33.0)	(38.1)	(101.6)	(G 1/8)	(28.6)	(12.7)

NVP80V



- » High Productivity – non-clogging design reduces downtime
- » Strong hold – powerful vacuum up to 28"Hg [948mbar]
- » Mounts Easily – compact and lightweight
- » Fast Response – installs close to vacuum point
- » Efficient – minimal air consumption
- » Reliable operation – straight-through design with no moving parts

Technical Data

Fluid
Filtered (100 Micron) unlubricated, non-corrosive dry gases

Operating Temperature
-100° to -400° F (-73° to -204°C)
20° to -120° F (-7° to -49°C) (Valve)

Operating Pressure
80 PSI (5.5 bar) Standard or 60 PSI (4.1 bar)

Materials
Generator Body: Anodized Aluminum

Supply Line
3/8" OD (10mm)

Vacuum Line
3/8" OD (10mm)

Mounting Holes
Mounting holes accept 10-32[M5] screws

Electrical
24V -5% to 10% (VA, VB option)
12V -5% to 10% (VC option)

Power Consumption (Watts)
1.6 Watts

Response Times
8 milliseconds

Cycle Rate (Cycles/second)
45

Average Valve Life
50 million cycles

Electrical Connection
11.8" Flying Lead

LED Indicator with Manual Override
Yes

Control Valve
12V (VC option) or 24V normally closed (VA option) or 24V normally open (VB option)

Performance Level Designations
"L", "X" 0-10"Hg [0 to 339mbar] for low vacuum/high flow applications
"M", "Y" 0-20"Hg [0 to 677mbar] for medium vacuum/high flow applications
"H", "Z" 0-28"Hg [0 to 948mbar] for high vacuum/standard flow applications



Product options
Standard (NVP80V)
Pneumatic blow-off (NVP8XV)
Multi-port (NVP80M)
Air Saver (NVP80C)

Standard Models

Part number	Valve	Max. Vacuum Level	Max. Vacuum Flow	Air Consumption	Silencer
NVP80VA-200M-S08A00	NC 24V	20"Hg	6.00 SCFM	3.80 SCFM	NST6A Silencer
NVP80VA-200H-S08A00	NC 24V	28"Hg	5.40 SCFM	7.80 SCFM	NST6A Silencer
NVP80VA-250M-S10A00	NC 24V	20"Hg	9.50 SCFM	7.80 SCFM	NST6A Silencer
NVP80VA-250H-S10A00	NC 24V	28"Hg	9.00 SCFM	12.50 SCFM	NST6A Silencer

Accessories

Option selector

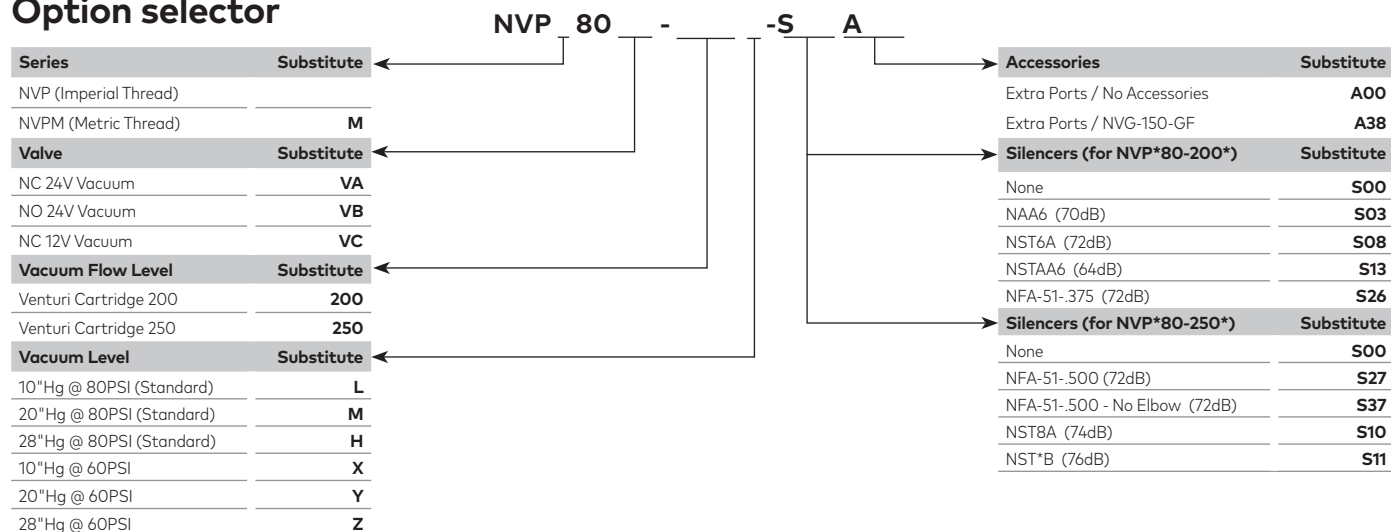



Accessories

Model	Inline Fitting	Swivel Elbow Fitting	Vacuum Fitting	Bellows Cup	Flat Cup
NVP80-200M-S08A00	124250628	124470618	NVCF5-38M NVCF27-38M	NSM045****	NUC*****
NVP80-200H-S08A00	124250628	124470618	NVCF5-38M NVCF27-38M	NSM045****	NUC*****
NVP80-250M-S10A00	124250628	124470618	NVCF5-38M NVCF27-38M	NSM045****	NUC*****
NVP80-250H-S10A00	124250628	124470618	NVCF5-38M NVCF27-38M	NSM045****	NUC*****

*Proper selection of vacuum cups depends on the application. Cups are available in various durometers, colors and materials. If you do not see what you are looking for, please consult factory
 *The fittings, cups, and spring levelers listed are a small selection of possible options please refer to the specific catalog section

Dimensions inches (mm)

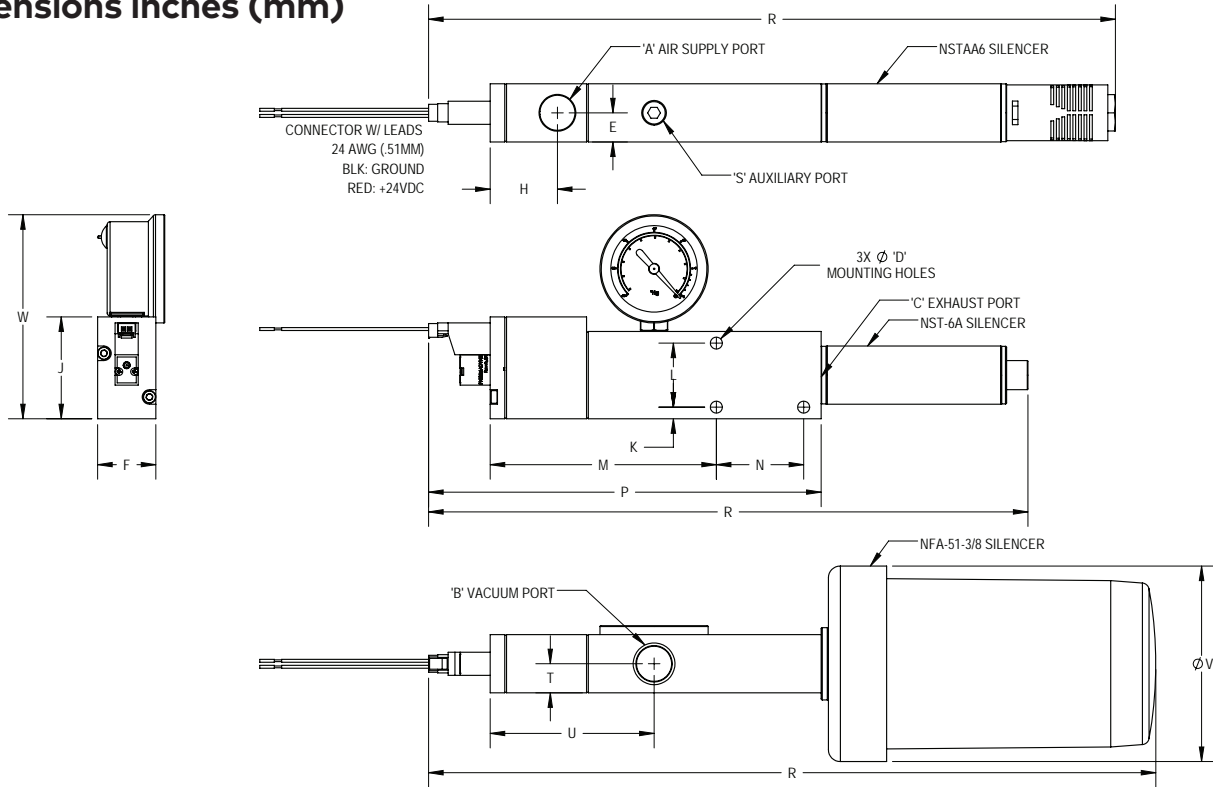

Model	Units	A	B	C	D	E	F	H	J	K	L	M	N	P	R	S	T	U	V	W
NVP80-200*-S03A38	Imperial	1/8 NPTF	3/8 NPTF	3/8 NPTF	0.21	0.50	1.00	1.16	1.75	0.20	1.10	3.89	1.50	6.75	11.80	1/8 NPT F	0.50	2.82	3.36	3.51
NVP80-200*-S08A38	Imperial	1/8 NPTF	3/8 NPTF	3/8 NPTF	0.21	0.50	1.00	1.16	1.75	0.20	1.10	3.89	1.50	6.75	10.30	1/8 NPT F	0.50	2.82	3.36	3.51
NVP80-200*-S13A38	Imperial	1/8 NPTF	3/8 NPTF	3/8 NPTF	0.21	0.50	1.00	1.16	1.75	0.20	1.10	3.89	1.50	6.75	12.50	1/8 NPT F	0.50	2.82	3.36	3.51
NVPM80-200*-S13A38	(Metric)	(G 1/8)	(G 3/8)	(G 3/8)	(5.3)	(12.7)	(25.4)	(29.5)	(44.4)	(5.1)	(27.9)	(98.8)	(38.1)	(171.4)	(299.7)	(G 1/8)	(12.7)	71.6	(85.3)	(89.2)
NVPM80-200*-S13A38	(Metric)	(G 1/8)	(G 3/8)	(G 3/8)	(5.3)	(12.7)	(25.4)	(29.5)	(44.4)	(5.1)	(27.9)	(98.8)	(38.1)	(171.4)	(261.6)	(G 1/8)	(12.7)	71.6	(85.3)	(89.2)
NVPM80-200*-S26A38	(Metric)	(G 1/8)	(G 3/8)	(G 3/8)	(5.3)	(12.7)	(25.4)	(29.5)	(44.4)	(5.1)	(27.9)	(98.8)	(38.1)	(171.4)	(317.5)	(G 1/8)	(12.7)	71.6	(85.3)	(89.2)

Accessories

Model	Inline Fitting	Swivel Elbow Fitting	Vacuum Fitting	Bellows Cup	Flat Cup
NVP80-200M-S08A00	124250628	124470618	NVCF5-38M NVCF27-38M	NSM045****	NUC*****
NVP80-200H-S08A00	124250628	124470618	NVCF5-38M NVCF27-38M	NSM045****	NUC*****
NVP80-250M-S10A00	124250628	124470618	NVCF5-38M NVCF27-38M	NSM045****	NUC*****
NVP80-250H-S10A00	124250628	124470618	NVCF5-38M NVCF27-38M	NSM045****	NUC*****

*Proper selection of vacuum cups depends on the application. Cups are available in various durometers, colors and materials. If you do not see what you are looking for, please consult factory
 *The fittings, cups, and spring levelers listed are a small selection of possible options please refer to the specific catalog section

Dimensions inches (mm)

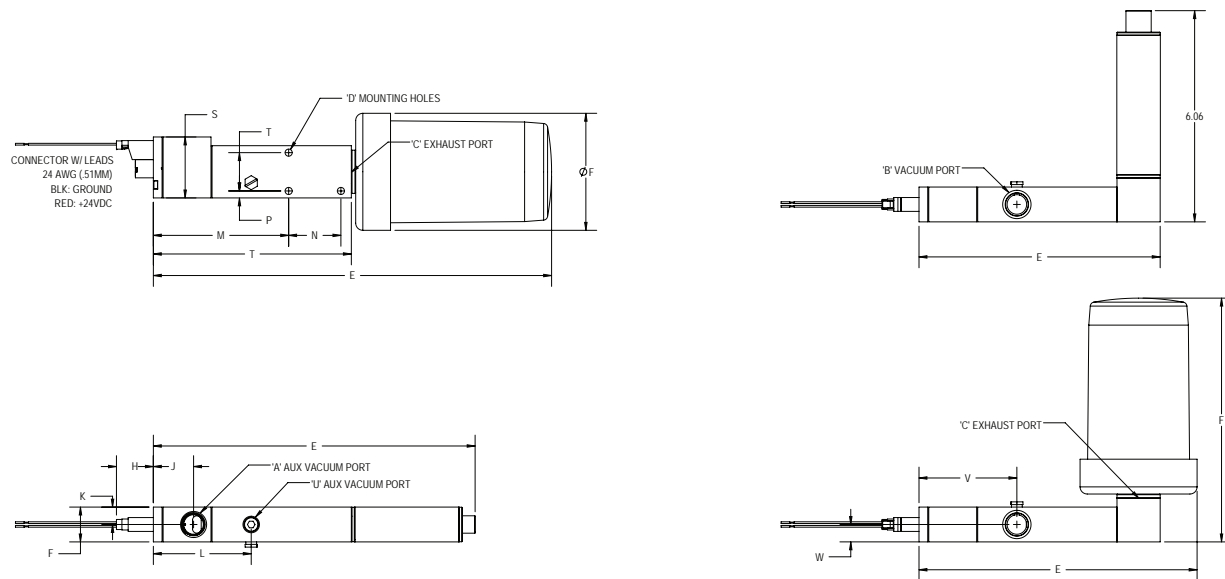

Model	Units	A	B	C	D	E	F	H	J	K	L	M	N	P	R	S	T	V	W
NVP80-250*-S00A38	Imperial	1/4 NPTF	3/8 NPTF	1/2 NPTF	0.21	11.44	3.36	1.06	1.16	0.50	2.81	3.89	1.50	0.20	1.10	1.75	5.69	2.81	0.50
NVP80-250*-S27A38	Imperial	1/4 NPTF	3/8 NPTF	1/2 NPTF	0.21	7.99	7.00	1.06	1.16	0.50	2.81	3.89	1.50	0.20	1.10	1.75	5.69	2.81	0.50
NVP80-250*-S10A38	Imperial	1/4 NPTF	3/8 NPTF	1/2 NPTF	0.21	6.93	6.06	1.06	1.16	0.50	2.81	3.89	1.50	0.20	1.10	1.75	5.69	2.81	0.50
NVP80-250*-S11A38	Imperial	1/4 NPTF	3/8 NPTF	1/2 NPTF	0.21	9.24	1.00	1.06	1.16	0.50	2.81	3.89	1.50	0.20	1.10	1.75	5.69	2.81	0.50
NVPM80-250*-S08A38	(Metric)	(G 1/4)	(G 3/8)	(G 1/2)	(5.3)	(290.6)	(85.3)	(26.9)	(29.1)	(12.7)	(71.4)	(98.8)	(38.1)	(5.1)	(27.9)	(44.4)	(144.5)	(71.4)	(12.7)
NVPM80-250*-S13A38	(Metric)	(G 1/4)	(G 3/8)	(G 1/2)	(5.3)	(202.9)	(177.8)	(26.9)	(29.1)	(12.7)	(71.4)	(98.8)	(38.1)	(5.1)	(27.9)	(44.4)	(144.5)	(71.4)	(12.7)
NVPM80-250*-S10A38	(Metric)	(G 1/4)	(G 3/8)	(G 1/2)	(5.3)	(176.0)	(153.9)	(26.9)	(29.1)	(12.7)	(71.4)	(98.8)	(38.1)	(5.1)	(27.9)	(44.4)	(144.5)	(71.4)	(12.7)
NVPM80-250*-S11A38	(Metric)	(G 1/4)	(G 3/8)	(G 1/2)	(5.3)	(234.7)	(25.4)	(26.9)	(29.1)	(12.7)	(71.4)	(98.8)	(38.1)	(5.1)	(27.9)	(44.4)	(144.5)	(71.4)	(12.7)

NVP8X

Pneumatic Blow-off



- » All in one vacuum and blow-off - only compressed air required
- » High Productivity – non-clogging design reduces downtime
- » Strong hold – powerful vacuum up to 28" Hg [948mbar]
- » Mounts Easily – compact and lightweight
- » Fast Response – installs close to vacuum point
- » Efficient – minimal air consumption
- » Reliable operation – straight-through design with no moving parts

Technical Data

Fluid

Filtered (100 Micron) unlubricated, non-corrosive dry gases

Operating Temperature

32° to -125° F (0° to -52°C)

Operating Pressure

80 PSI (5.5 bar) Standard or 60 PSI (4.1 bar)

Materials

Generator Body: Anodized Aluminum

Generator Options

B1 adjustable version allows the user to set the intensity of the blow-off from no blow-off to full blow-off

Cycle Rates

Up to 900/min

Blow-off Response Time

Instantaneous

Blow-off Duration

100 milliseconds (based on system design)

Orientation

Any

Supply Line

3/8" OD (10mm) tube

Vacuum Line

3/8" OD (10mm) tube

Mounting Holes

Mounting holes accept 10-32 [M5] screws

Control Valve

12V (VC/VF option) or 24V normally closed (BA/BD option) or 24V normally open (BB/BE option)

Performance Level Designations

"L", "X" 0-10"Hg [0 to 339mbar] for low vacuum/high flow applications

"M", "Y" 0-20"Hg [0 to 677mbar] for medium vacuum/high flow applications

"H", "Z" 0-28"Hg [0 to 948mbar] for high vacuum/standard flow applications

Product options

Standard (NVP80)

Valve controlled vacuum (NVP80)

Pneumatic blow-off (NVP8XV)

Multi-port (NVP80M)

Air Saver (NVP80C)



Standard Models

Part number	Max. Vacuum Level	Max. Vacuum Flow	Air Consumption	Silencer
NVP8XB0-200M-S08A00	20"Hg	6.00 SCFM	4.80 SCFM	NST6A Silencer
NVP8XB0-200H-S08A00	28"Hg	5.40 SCFM	7.80 SCFM	NST6A Silencer
NVP8XBA-200M-S08A00	20"Hg	6.00 SCFM	4.80 SCFM	NST6A Silencer
NVP8XBA-200H-S08A00	28"Hg	5.40 SCFM	7.80 SCFM	NST6A Silencer

Accessories

Option selector

Series	Substitute	NVP 8XB - -S A00	Accessories	Substitute
NVP (Imperial Thread)			Extra Port if Available / No Accessories	A00
NVPM (Metric Thread)	M		Silencers	Substitute
Blowoff	Substitute		None	S00
Non-adjustable (Standard), No valve	BO		NAA6 (70dB)	S03
Adjustable, No valve	B1		NST6A (72dB)	S08
Non-Adjustable, NC 24V Vacuum	BA		NSTAA6 (64dB)	S13
Non-Adjustable, NO 24V Vacuum	BB		NFA-51-.375 (72dB)	S26
Non-Adjustable, NC 12V Vacuum	BC			
Adjustable, NC 24V Vacuum	BD			
Adjustable, NO 24V Vacuum	BE			
Adjustable, NC 12V Vacuum	BF			
Vacuum Flow Level	Substitute			
Venturi Cartridge 200	200			
Vacuum Level	Substitute			
10"Hg @ 80PSI (Standard)	L			
20"Hg @ 80PSI (Standard)	M			
28"Hg @ 80PSI (Standard)	H			
10"Hg @ 60PSI	X			
20"Hg @ 60PSI	Y			
28"Hg @ 60PSI	Z			

NVP8X

Pneumatic Blow-off



Accessories

Model	Inline Fitting	Swivel Elbow Fitting	Vacuum Fitting	Bellows Cup	Flat Cup
NVP8XB0-200M-S08A00	124250628	124470628	NVCF5-38M NVCF27-38M	NSM045****	NUC*****
NVP8XB0-200H-S08A00	124250628	124470628	NVCF5-38M NVCF27-38M	NSM045****	NUC*****

*Proper selection of vacuum cups depends on the application. Cups are available in various durometers, colors and materials. If you do not see what you are looking for, please consult factory*The fittings, cups, and spring levelers listed are a small selection of possible options please refer to the specific catalog section

Dimensions inches (mm)

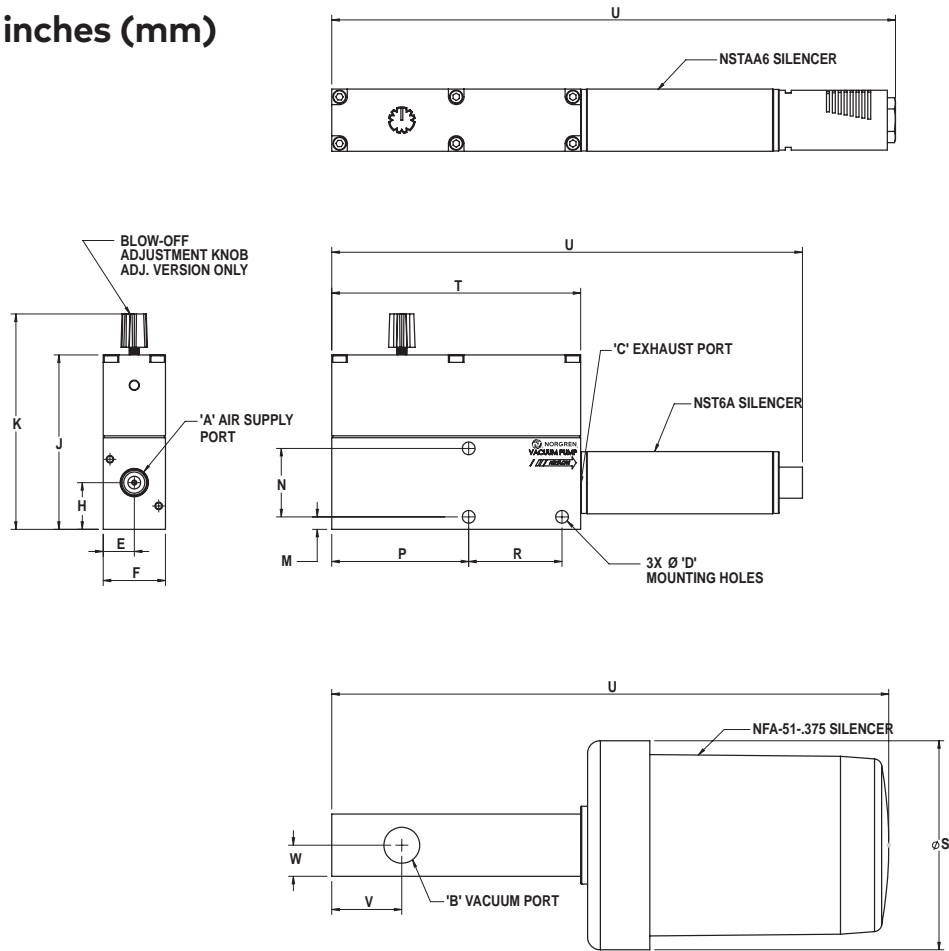

Model	Units	A	B	C	D	E	F	H	J	K*	M	N	P	R	S	T	U	V	W
NVP8XB0-****-S08A00	Imperial	1/4 NPTF	3/8 NPTF	3/8 NPTF	0.21	0.50	1.00	0.75	2.80	3.46	0.20	1.10	2.20	1.50	3.36	4.00	7.56	1.13	0.50
NVP8XB0-****-S13A00	Imperial	1/4 NPTF	3/8 NPTF	3/8 NPTF	0.21	0.50	1.00	0.75	2.80	3.46	0.20	1.10	2.20	1.50	3.36	4.00	9.06	1.13	0.50
NVP8XB0-****-S26A00	Imperial	1/4 NPTF	3/8 NPTF	3/8 NPTF	0.21	0.50	1.00	0.75	2.80	3.46	0.20	1.10	2.20	1.50	3.36	4.00	9.70	1.13	0.50
NVPM8XB0-****-S08A00	(Metric)	(G 1/4)	(G 3/8)	(G 3/8)	(5.3)	(12.7)	(25.4)	(19.1)	(71.1)	(87.9)	(5.1)	(27.9)	(55.9)	(38.1)	(85.3)	(101.6)	(192.0)	(28.6)	(12.7)
NVPM8XB0-****-S13A00	(Metric)	(G 1/4)	(G 3/8)	(G 3/8)	(5.3)	(12.7)	(25.4)	(19.1)	(71.1)	(87.9)	(5.1)	(27.9)	(55.9)	(38.1)	(85.3)	(101.6)	(230.1)	(28.6)	(12.7)
NVPM8XB0-****-S26A00	(Metric)	(G 1/4)	(G 3/8)	(G 3/8)	(5.30)	(12.7)	(25.4)	(19.1)	(71.1)	(87.9)	(5.1)	(27.9)	(55.9)	(38.1)	(85.3)	(101.6)	(246.4)	(28.6)	(12.7)



Accessories

Model	Inline Fitting	Swivel Elbow Fitting	Vacuum Fitting	Bellows Cup	Flat Cup
NVP8XB0-200M-S08A00	124250628	124470628	NVCF5-38M NVCF27-38M	NSM045****	NUC*****
NVP8XB0-200H-S08A00	124250628	124470628	NVCF5-38M NVCF27-38M	NSM045****	NUC*****

*Proper selection of vacuum cups depends on the application. Cups are available in various durometers, colors and materials. If you do not see what you are looking for, please consult factory
 *The fittings, cups, and spring levelers listed are a small selection of possible options please refer to the specific catalog section

Dimensions inches (mm)

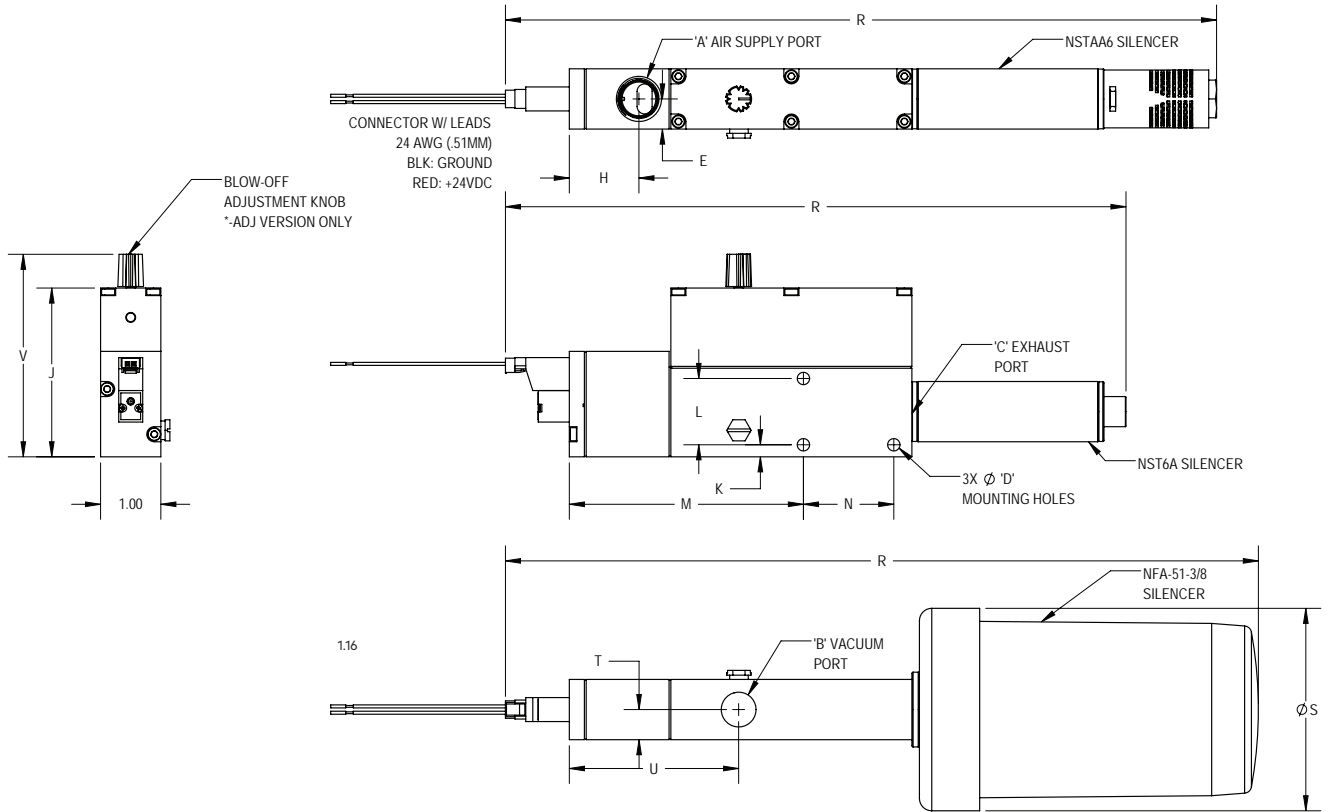

Model	Units	A	B	C	D	E	F	H	J	K*	M	N	R	S	T	U	V
NVP8XBA-****-S08A00	Imperial	3/8 NPTF	1/4 NPTF	3/8 NPTF	0.21	0.50	1.00	1.16	2.80	0.20	3.89	1.50	10.30	3.36	0.50	2.81	3.36
NVP8XBA-****-S13A00	Imperial	3/8 NPTF	1/4 NPTF	3/8 NPTF	0.21	0.50	1.00	1.16	2.80	0.20	3.89	1.50	11.80	3.36	0.50	2.81	3.36
NVP8XBA-****-S26A00	Imperial	3/8 NPTF	1/4 NPTF	3/8 NPTF	0.21	0.50	1.00	1.16	2.80	0.20	3.89	1.50	12.50	3.36	0.50	2.81	3.36
NVPM8XBA-****-S08A00	(Metric)	(G 3/8)	(G 1/4)	(G 3/8)	(5.3)	(12.7)	(25.4)	(29.5)	(71.1)	(5.1)	(98.8)	(38.1)	(261.6)	(85.3)	(12.7)	(71.4)	(85.3)
NVPM8XBA-****-S13A00	(Metric)	(G 3/8)	(G 1/4)	(G 3/8)	(5.3)	(12.7)	(25.4)	(29.5)	(71.1)	(5.1)	(98.8)	(38.1)	(299.7)	(85.3)	(12.7)	(71.4)	(85.3)
NVPM8XBA-****-S26A00	(Metric)	(G 3/8)	(G 1/4)	(G 3/8)	(5.3)	(12.7)	(25.4)	(29.5)	(71.1)	(5.1)	(98.8)	(38.1)	(317.5)	(85.3)	(12.7)	(71.4)	(85.3)



NVP80M

Multi-port

- » Multi-port version - distribute vacuum to multiple locations
- » High Productivity – non-clogging design reduces downtime
- » Strong hold – powerful vacuum up to 28" Hg [948mbar]
- » Mounts Easily – compact and lightweight
- » Fast Response – installs close to vacuum point
- » Efficient – minimal air consumption
- » Reliable operation – straight-through design with no moving parts

Technical Data

Fluid
Filtered (100 Micron) unlubricated, non-corrosive dry gases

Operating Temperature
-100° to ~400° F (-73° to ~204°C)
20° to 120° F (-7° to 49°C) (Valve)

Operating Pressure
80 PSI (5.5 bar) Standard or 60 PSI (4.1 bar)

Materials
Generator Body: Anodized Aluminum

Supply Line
3/8" OD (10mm)

Vacuum Line
3/8" OD (10mm)

Mounting Holes
Mounting holes accept 10-32 [M5] screws

Electrical
24V - 5% to 10% (MA/MB option)
12V - 5% to 10% (MC option)

Power Consumption
1.6 watts

Response Times
8 milliseconds

Average Valve Life
50 million cycles

Electrical Connection
11.8" Flying Lead

LED Indicator with Manual Override
Yes

Control Valve
12V (MC option) or 24V normally closed (MA option) or 24V normally open (MB option)

Performance Level Designations
"L", "X" 0-10"Hg [0 to 339mbar] for low vacuum/high flow applications
"M", "Y" 0-20"Hg [0 to 677mbar] for medium vacuum/high flow applications
"H", "Z" 0-28"Hg [0 to 948mbar] for high vacuum/standard flow applications



Product options
Standard (NVP80)
Valve controlled vacuum (NVP80)
Pneumatic blow-off (NVP8XV)
Multi-port (NVP80M)
Air Saver (NVP80C)

Standard Models

Part number	Valve	Max. Vacuum Level	Max. Vacuum Flow	Air Consumption	Silencer
NVP80M0-200M-S08A38	None	20"Hg	6.00 SCFM	4.80 SCFM	NST6A Silencer
NVP80M0-200H-S08A38	None	28"Hg	5.40 SCFM	7.80 SCFM	NST6A Silencer
NVP80M0-250M-S10A38	None	20"Hg	9.50 SCFM	7.80 SCFM	NST8A Silencer
NVP80M0-250H-S10A38	None	28"Hg	9.00 SCFM	12.50 SCFM	NST8A Silencer
NVP80MA-200M-S08A38	NC 24V	20"Hg	6.00 SCFM	4.80 SCFM	NST8A Silencer
NVP80MA-200H-S08A38	NC 24V	28"Hg	5.40 SCFM	7.80 SCFM	NST6A Silencer
NVP80MA-250M-S10A38	NC 24V	20"Hg	9.50 SCFM	7.80 SCFM	NST8A Silencer
NVP80MA-250H-S10A38	NC 24V	28"Hg	9.00 SCFM	12.50 SCFM	NST8A Silencer

Accessories

Option selector

NVP 80M - -S A

Series	Substitute	Accessories	Substitute
NVP (Imperial Thread)		Extra Ports / NVG-150-GF	A38
NVPM (Metric Thread)	M	Extra Ports / NVTMV-QD-6 / NVG-150-GF	A22
Valve	Substitute	Extra Ports / NVSMN-QD-6 / NVG-150-GF	A24
Multi-Port, No Valve	MO	Extra Ports / NVSMP-QD-6 / NVG-150-GF	A26
Multi-Port, NC 24V Vacuum	MA	Silencers (for NVP*80-200*)	Substitute
Multi-Port, NO 24V Vacuum	MB	None	S00
Multi-Port, NC 12V Vacuum	MC	NAA6 (70dB)	S03
Vacuum Flow Level	Substitute	NST6A (72dB)	S08
Venturi Cartridge 200	200	NSTAA6 (64dB)	S13
Venturi Cartridge 250	250	Silencers (for NVP*80-250*)	
Vacuum Level	Substitute	NST8A (74dB)	S10
10"Hg @ 80PSI (Standard)	L		
20"Hg @ 80PSI (Standard)	M		
28"Hg @ 80PSI (Standard)	H		
10"Hg @ 60PSI	X		
20"Hg @ 60PSI	Y		
28"Hg @ 60PSI	Z		



Accessories

Model	Inline Fitting	Pneufit Swivel Male Elbow	Vacuum Swivel Fitting
NVP80M0-200M-S08A00	124250628	124470628	124470628
NVP80M0-200H-S08A00	124250628	124470628	124470628
NVP80M0-250M-S10A00	124250638	124470638	124470628
NVP80M0-250H-S10A00	124250638	124470638	124470628

*Proper selection of vacuum cups depends on the application. Cups are available in various durometers, colors and materials. If you do not see what you are looking for, please consult factory
 *The fittings, cups, and spring levelers listed are a small selection of possible options please refer to the specific catalog section

Dimensions inches (mm)

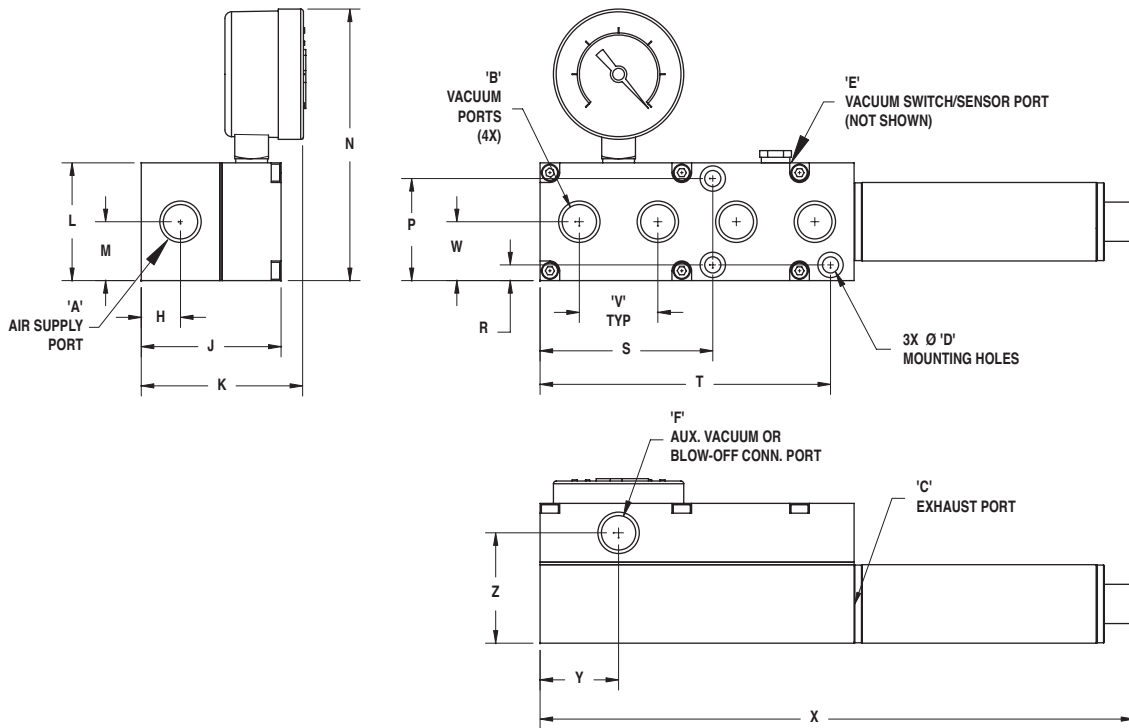

Model	Units	A	B	C	D	E	F	H	J	K	L	M	N	P	R	S	T	V	W	X	Y	Z
NVP80M0-200*-S03A38	Imperial	1/4 NPTF	1/4 NPTF	3/8 NPTF	0.21	10-32	1/4 NPTF	0.50	1.78	2.06	1.50	0.75	3.46	1.30	0.20	2.20	3.70	1.00	0.75	6.00	1.00	1.41
NVP80M0-200*-S08A38	Imperial	1/4 NPTF	1/4 NPTF	3/8 NPTF	0.21	10-32	1/4 NPTF	0.50	1.78	2.06	1.50	0.75	3.46	1.30	0.20	2.20	3.70	1.00	0.75	7.56	1.00	1.41
NVP80M0-200*-S13A38	Imperial	1/4 NPTF	1/4 NPTF	3/8 NPTF	0.21	10-32	1/4 NPTF	0.50	1.78	2.06	1.50	0.75	3.46	1.30	0.20	2.20	3.70	1.00	0.75	9.00	1.00	1.41
NVPM80M0-200*-S03A38	(Metric)	(G 1/4)	(G 1/4)	(G 3/8)	(5.2)	(M5)	(G 1/4)	(12.7)	(45.2)	(52.2)	(38.1)	(19.1)	(87.9)	(33.0)	(5.1)	(55.9)	(94.0)	(25.4)	(19.1)	(152.4)	(25.4)	(35.7)
NVPM80M0-200*-S08A38	(Metric)	(G 1/4)	(G 1/4)	(G 3/8)	(5.2)	(M5)	(G 1/4)	(12.7)	(45.2)	(52.2)	(38.1)	(19.1)	(87.9)	(33.0)	(5.1)	(55.9)	(94.0)	(25.4)	(19.1)	(192.0)	(25.4)	(35.7)
NVPM80M0-200*-S13A38	(Metric)	(G 1/4)	(G 1/4)	(G 3/8)	(5.2)	(M5)	(G 1/4)	(12.7)	(45.2)	(52.2)	(38.1)	(19.1)	(87.9)	(33.0)	(5.1)	(55.9)	(94.0)	(25.4)	(19.1)	(228.6)	(25.4)	(35.7)

NVP80M

Multi-port



Accessories

Model	Inline Fitting	Pneufit Swivel Male Elbow	Vacuum Swivel Fitting
NVP80M0-200M-S08A00	124250628	124470628	124470628
NVP80M0-200H-S08A00	124250628	124470628	124470628
NVP80M0-250M-S10A00	124250638	124470638	124470628
NVP80M0-250H-S10A00	124250638	124470638	124470628

*Proper selection of vacuum cups depends on the application. Cups are available in various durometers, colors and materials. If you do not see what you are looking for, please consult factory
 *The fittings, cups, and spring levelers listed are a small selection of possible options please refer to the specific catalog section

Dimensions inches (mm)

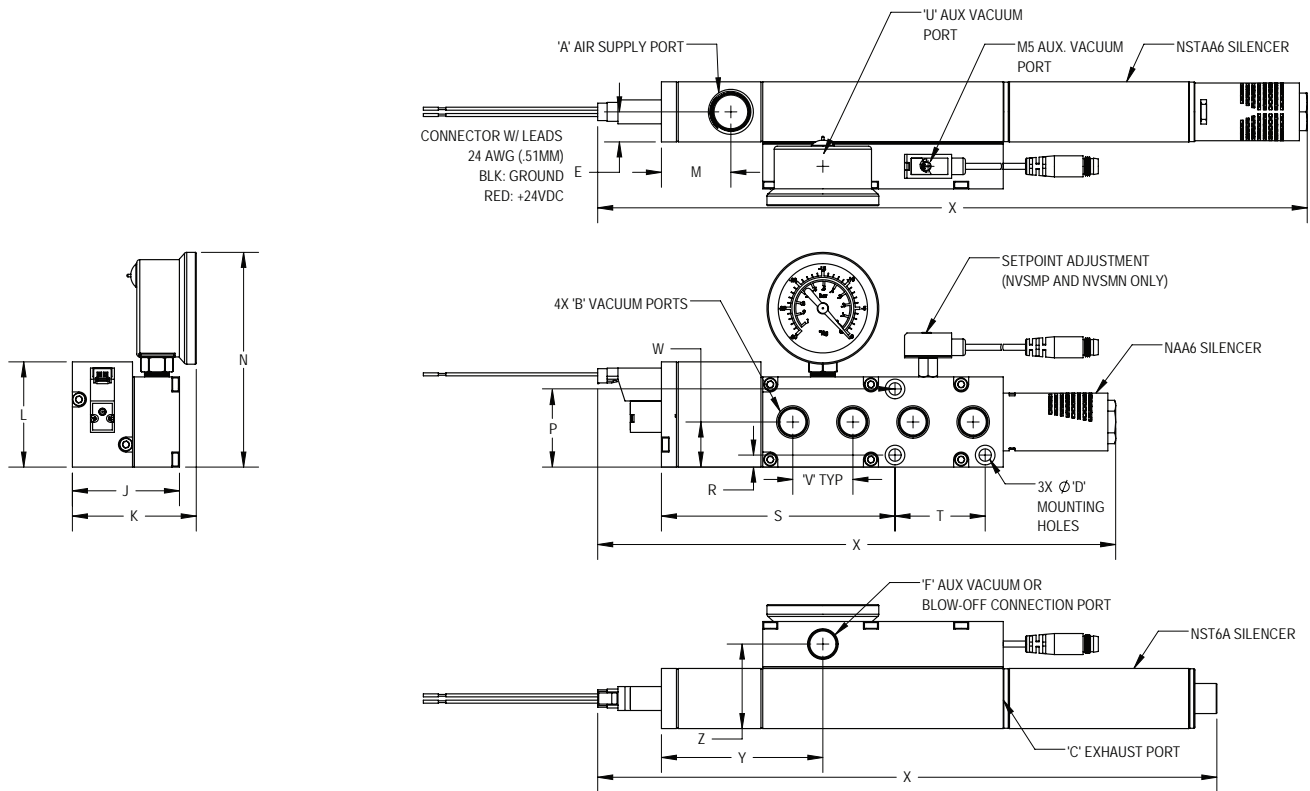

Model	Units	A	B	C	D	E	F	J	K	L	M	N	P	R	S	T	U	V	W	X	Y	Z
NVP80MA-200*-S03A38	Imperial	3/8 NPTF	1/4 NPTF	3/8 NPTF	0.21	0.50	1/4 NPTF	1.78	2.06	1.75	1.16	3.51	1.30	0.20	3.89	1.50	1/8 NPTF	1.00	0.75	11.80	2.69	1.41
NVP80MA-200*-S08A38	Imperial	3/8 NPTF	1/4 NPTF	3/8 NPTF	0.21	0.50	1/4 NPTF	1.78	2.06	1.75	1.16	3.51	1.30	0.20	3.89	1.50	1/8 NPTF	1.00	0.75	10.30	2.69	1.41
NVP80MA-200*-S13A38	Imperial	3/8 NPTF	1/4 NPTF	3/8 NPTF	0.21	0.50	1/4 NPTF	1.78	2.06	1.75	1.16	3.51	1.30	0.20	3.89	1.50	1/8 NPTF	1.00	0.75	8.62	2.69	1.41
NVPM80MA-200*-S03A38	(Metric)	(G 3/8)	(G 1/4)	(G 3/8)	(5.3)	(12.7)	(G 1/4)	(45.2)	(52.3)	(44.5)	(19.1)	(89.2)	(33.0)	(5.1)	(98.8)	(38.1)	G1/8	(25.4)	(19.1)	(299.7)	(68.3)	(35.8)
NVPM80MA-200*-S08A38	(Metric)	(G 3/8)	(G 1/4)	(G 3/8)	(5.3)	(12.7)	(G 1/4)	(45.2)	(52.3)	(44.5)	(19.1)	(89.2)	(33.0)	(5.1)	(98.8)	(38.1)	G1/8	(25.4)	(19.1)	(261.6)	(68.3)	(35.8)
NVPM80MA-200*-S13A38	(Metric)	(G 3/8)	(G 1/4)	(G 3/8)	(5.3)	(12.7)	(G 1/4)	(45.2)	(52.3)	(44.5)	(19.1)	(89.2)	(33.0)	(5.1)	(98.8)	(38.1)	G1/8	(25.4)	(19.1)	(218.9)	(68.3)	(35.8)



For more information or for additional configurations, please contact us at NASInsideSales@imi-precision.com

NVP80M

Multi-port



Dimensions inches (mm)

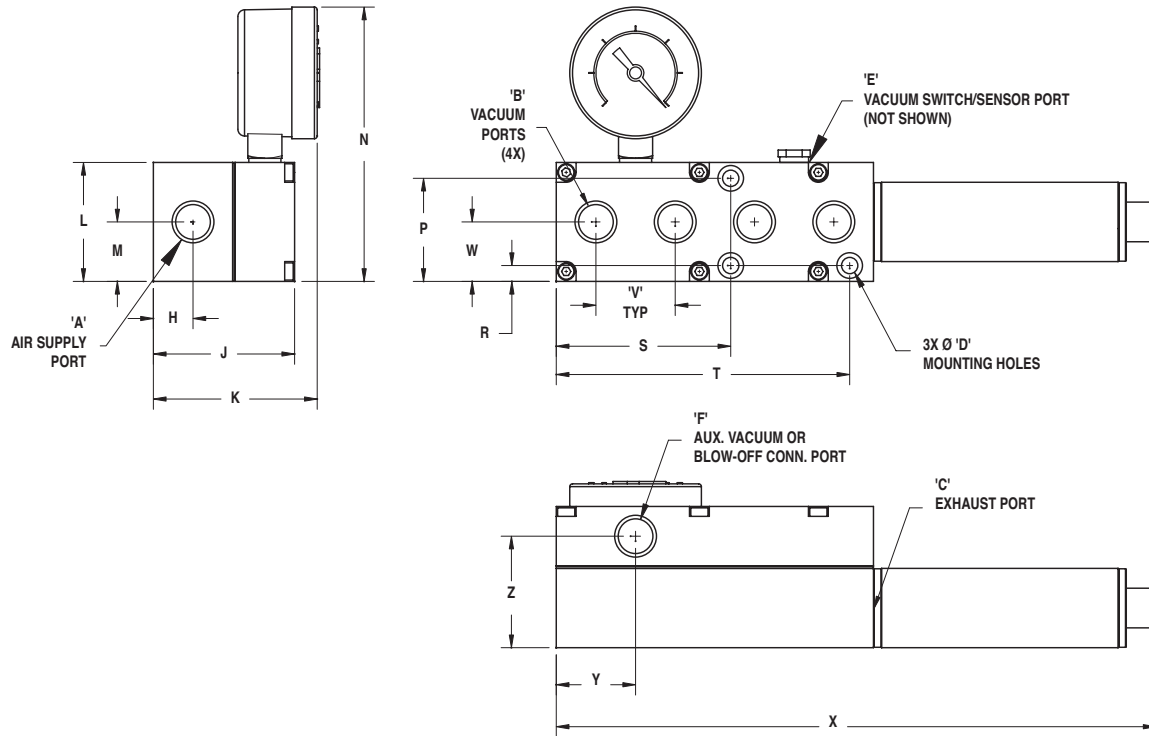

Model	Units	A	B	C	D	E	F	H	J	K	L	M	N	P	R	S	T	V	W	X	Y	Z
NVP8XB0-250°-S03A38	Imperial	3/8 NPTF	1/4 NPTF	1/2 NPTF	0.21	10-32	1/4 NPTF	0.50	1.78	2.07	1.50	0.75	3.46	1.30	0.20	2.20	3.70	1.00	0.75	7.56	1.00	1.41
NVPM8XB0-250°-S03A38	(Metric)	(G 3/8)	(G 1/4)	(G 1/2)	(5.2)	M5	(G 1/4)	(12.7)	(45.2)	(52.5)	(38.1)	(19.1)	(87.9)	(33.0)	(5.1)	(55.9)	(94.0)	(25.4)	(19.1)	(192.1)	(25.4)	(35.7)

NVP80M

Multi-port



Dimensions inches (mm)

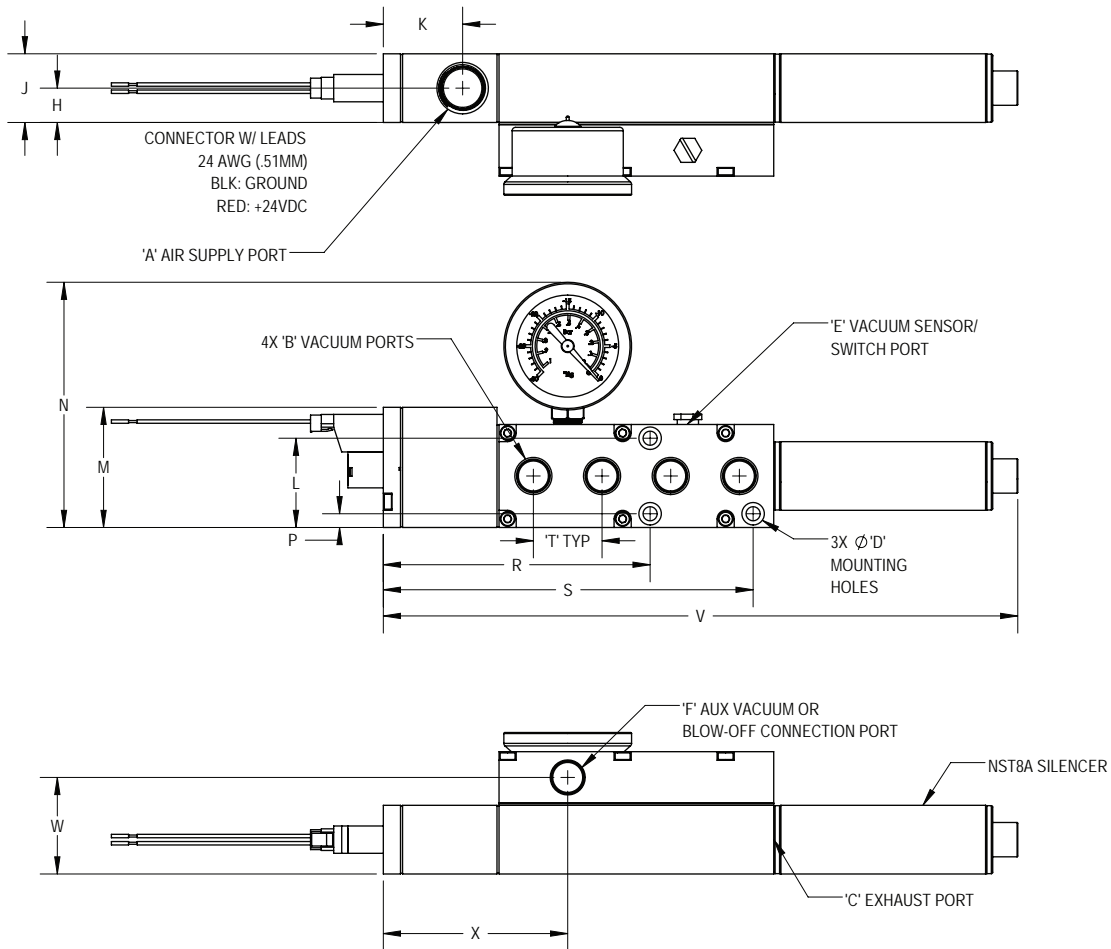

Model	Units	A	B	C	D	E	F	H	J	K	L	M	N	P	R	S	T	V	W	X
NVP8XBA-250*-S03A38	Imperial	3/8 NPTF	1/4 NPTF	3/8 NPTF	0.21	10-32	1/4 NPTF	0.50	1.00	1.16	1.30	1.75	3.57	0.20	3.89	5.39	1.00	9.24	1.41	2.69
NVPM8XBA-250*-S03A38	(Metric)	(G 3/8)	(G 1/4)	(G 3/8)	(5.3)	M5	(G 1/4)	(12.7)	(25.4)	(29.5)	(33.0)	(44.5)	(90.7)	(5.1)	(98.8)	(136.9)	(25.4)	(234.7)	(35.8)	(68.3)

NVP80C

Air Saver



- » Energy efficient – compressed air on only when needed, automatic shut-off
- » High Productivity – non-clogging design reduces downtime
- » Strong hold – powerful vacuum up to 28" Hg [948mbar]
- » Mounts Easily – compact and lightweight
- » Fast Response – installs close to vacuum point
- » Efficient – minimal air consumption
- » Reliable operation – straight-through design with no moving parts

Technical Data

Fluid

Filtered (100 Micron) unlubricated, non-corrosive dry gases

Operating Temperature

-30° to ~250° F (-34° to 121°C)

Operating Pressure

80 PSI (5.5 bar) Standard or 60 PSI (4.1 bar)

Materials

Generator Body: Anodized Aluminum

Supply/Vacuum Line

3/8" OD (10mm) for size 200

1/2" OD (12mm) for size 250

Mounting Holes

Mounting holes accept 10-32 [M5] screws

Control Valve

3 way/2 position (faster part release), minimum orifice – 0.125" [3mm]

Performance Level

Designations

"M", "Y" 0-20" Hg [0 to 677mbar] for medium vacuum/ high flow applications

"H", "Z" 0-28" Hg [0 to 948mbar] for high vacuum/ standard flow applications

Generator Selection

1. Determine the desired evacuation time (speed)
2. Calculate the total volume of air to be evacuated in the system including vacuum lines, vessel/ cavity size, cups, etc.
3. Determine the desired vacuum level, "Hg/mbar

Application ex.: Evacuate

2 cu.ft. of air in 1 minute

(60 sec) at a vacuum

level of 21" Hg

Formula: Time (60 sec)/Cu.

ft (2) = 30 seconds per cu.ft.

(evacuation speed)



Product options

Standard (NVP80)

Valve controlled vacuum (NVP80)

Pneumatic blow-off (NVP8XV)

Multi-port (NVP80M)

Air Saver (NVP80C)

Standard Models

Part number	Max. Vacuum Level	Max. Vacuum Flow	Air Consumption	Silencer
NVP80C0-200M-S08A38	20" Hg	6.00 SCFM	4.80 SCFM	NST6A Silencer
NVP80C0-200H-S08A38	28" Hg	5.40 SCFM	7.80 SCFM	NST6A Silencer
NVP80C0-250M-S27A38	20" Hg	9.50 SCFM	7.80 SCFM	NFA-51-1/2 Silencer
NVP80C0-250H-S27A38	28" Hg	9.00 SCFM	12.50 SCFM	NFA-51-1/2 Silencer

Accessories

NVP80C

Air Saver



Option selector

Series		Substitute	NVP 80C0-	-S	A38	Accessories	Substitute
NVP (Imperial Thread)						Extra Ports / NVG-150-GF	A38
NVPM (Metric Thread)		M				Silencers	Substitute
Vacuum Flow Level		Substitute				NST6A (72dB)	S08
Venturi Cartridge 200		200				NFA-51-1/2	S27
Venturi Cartridge 250		250					
Vacuum Level		Substitute					
20"Hg @ 80PSI (Standard)		M					
28"Hg @ 80PSI (Standard)		H					
20"Hg @ 60PSI		Y					
28"Hg @ 60PSI		Z					

Dimensions inches (mm)

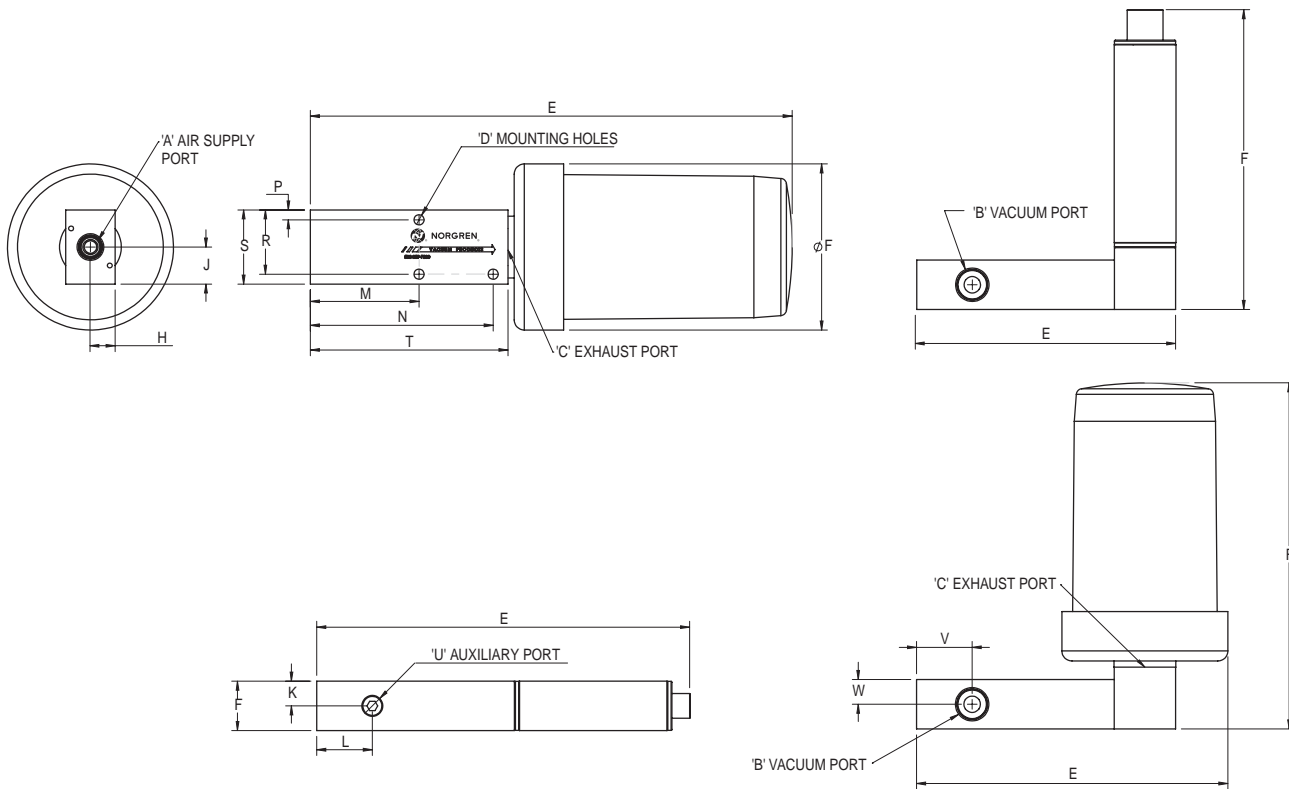

Model	Units	A	B	C	D	E	F	J	K	M	N	P	R	T	U	V	W
NVP80C0-200*-S08A38	Imperial	1/8 NPTF	1/2 NPTF	3/8 NPTF	0.21	1/8 NPTF	0.50	0.34	3.49	0.20	1.30	2.20	3.70	10.41	1.60	2.30	1.00
NVPM80C0-200*-S08A38	(Metric)	(G 1/8)	(G 1/2)	(G 3/8)	(5.2)	(G 1/8)	(12.7)	(8.6)	(88.6)	(5.1)	(33.0)	(55.9)	(94.0)	(264.5)	(40.6)	(58.4)	(25.4)



Dimensions inches (mm)

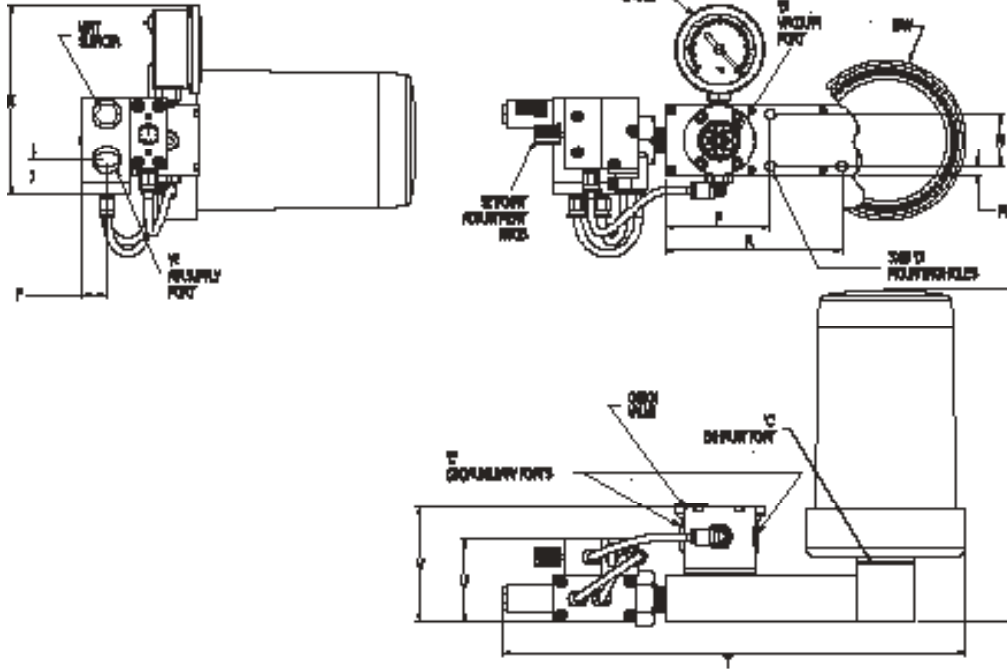

Model	Units	A	B	C	D	E	F	J	K	M	N	P	R	T	U	V	W	X
NVP80CO-250*-S27A38	Imperial	3/8 NPTF	1/2 NPTF	1/2 NPTF	0.21	1/8 NPTF	0.50	0.74	3.90	0.20	1.30	2.20	3.70	9.20	1.72	2.30	3.23	7.00
NVPM80CO-250*-S27A38	(Metric)	(G 3/8)	(G 1/2)	(G 1/2)	(5.3)	(G 1/8)	(12.7)	(18.9)	(99.0)	(5.1)	(33.0)	(55.9)	(94.0)	(233.7)	(43.7)	(58.4)	(82.0)	(177.8)

Performance Data

Model	Air Consumption SCFM (L/min)	Vacuum Level "Hg (mbar)	0"Hg (0)	3"Hg (102)	6"Hg (203)	9"Hg (305)	10"Hg (339)	12"Hg (406)	15"Hg (508)	18"Hg (609)	20"Hg (677)	21"Hg (711)	24"Hg (813)	27"Hg (914)	28"Hg (948)
200L	2.80 (79.3)	Vacuum Flow SCFM (L/min)	6.00 (169.9)	5.80 (164.2)	4.30 (121.8)	1.70 (48.1)	0.00 (0.0)	-	-	-	-	-	-	-	-
		Evacuation time (seconds)	0.00 (0.0)	0.77 (0)	2.05 (0.1)	4.62 (0.2)	13.34 (0.5)	-	-	-	-	-	-	-	-
250L	4.80 (135.9)	Vacuum Flow SCFM (L/min)	9.50 (269.0)	7.90 (223.7)	5.70 (161.4)	2.20 (62.3)	0.00 (0.0)	-	-	-	-	-	-	-	-
		Evacuation time (seconds)	0.00 (0.0)	0.52 (0.0)	1.28 (0.0)	3.08 (0.1)	7.95 (0.3)	-	-	-	-	-	-	-	-
200M	4.80 (135.9)	Vacuum Flow SCFM (L/min)	6.00 (169.9)	5.30 (150.1)	4.90 (138.8)	4.00 (113.3)	-	3.50 (99.1)	2.50 (70.8)	1.10 (31.1)	0.00 (0.0)	-	-	-	-
		Evacuation time (seconds)	0.00 (0.0)	0.75 (0.0)	1.90 (0.1)	3.20 (0.1)	-	5.30 (0.2)	8.70 (0.3)	17.10 (0.6)	42.60 (1.5)	-	-	-	-
250M	7.80 (220.9)	Vacuum Flow SCFM (L/min)	9.50 (269.0)	9.20 (260.5)	8.30 (235.0)	7.00 (198.2)	-	4.70 (133.1)	3.40 (96.3)	2.20 (62.3)	0.00 (0.0)	-	-	-	-
		Evacuation time (seconds)	0.00 (0.0)	0.45 (0.0)	1.10 (0.0)	2.40 (0.1)	-	3.80 (0.1)	6.00 (0.2)	9.70 (0.3)	15.40 (0.5)	-	-	-	-
200H	7.80 (220.9)	Vacuum Flow SCFM (L/min)	5.40 (152.9)	4.70 (133.1)	3.85 (109.0)	3.30 (93.4)	-	3.00 (85.0)	2.60 (73.6)	2.10 (59.5)	-	1.60 (45.3)	1.20 (34.0)	0.60 (17.0)	0.00 (0.0)
		Evacuation time (seconds)	0.00 (0.0)	1.20 (0.0)	2.10 (0.1)	3.40 (0.1)	-	5.20 (0.2)	7.70 (0.3)	11.50 (0.4)	-	20.00 (0.7)	33.50 (1.2)	62.60 (2.2)	98.10 (3.5)
250H	12.50 (354.0)	Vacuum Flow SCFM (L/min)	9.00 (254.9)	8.50 (240.7)	7.85 (222.3)	7.00 (198.2)	-	6.50 (184.1)	5.30 (150.1)	3.90 (110.4)	-	2.50 (70.8)	1.80 (51.0)	0.90 (25.5)	0.00 (0.0)
		Evacuation time (seconds)	0.00 (0.0)	0.75 (0.0)	1.30 (0.0)	2.20 (0.1)	-	3.50 (0.1)	5.60 (0.2)	9.10 (0.3)	-	17.40 (0.6)	30.10 (1.1)	56.00 (2.0)	76.00 (2.7)

Evacuation time in seconds based on 1 cubic foot volume / "Hg (1 Liter Volume / mbar)

Performance Data

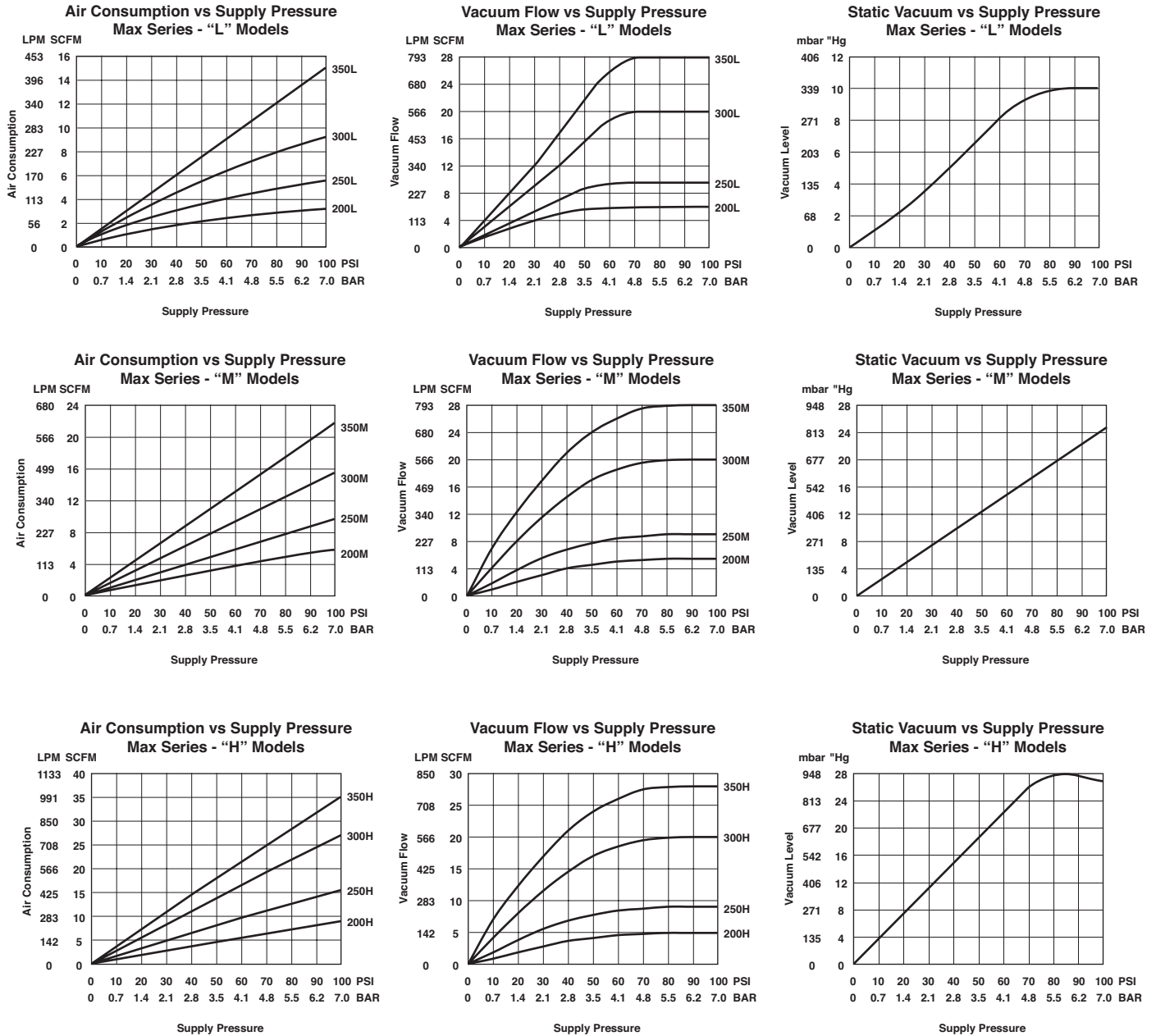

Notes: Standard operating pressure for Norgren generators is 80 PSI [5.5 bar]. Generators can be factory modified to run at other operating pressures i.e. 60 PSI [4.1 bar] etc. The values shown in the performance chart will remain the same for all operating pressures.

Warnings

Improper selection, misuse, age or malfunction of components used in systems can cause failure in various modes. The system designer is warned to consider the failure modes of all component parts and to provide adequate safeguards to prevent personal injury or damage to equipment or property in the event of such failure modes. System designers and end users are cautioned to consult instruction sheets and specifications available from the factory. The system designer/end user is responsible for verifying that all requirements for the application are met.

Warranty

The products described herein are warranted subject to seller's Standard Terms and Condition of Sale, available at seller's website.



- » High Productivity – non-clogging design reduces downtime
- » Strong hold – powerful vacuum up to 28" Hg [948mbar]
- » Mounts Easily – compact and lightweight
- » Fast Response – installs close to vacuum point
- » Efficient – minimal air consumption
- » Reliable operation – straight-through design with no moving parts

Technical Data

Fluid

Filtered (100 Micron) unlubricated, non-corrosive dry gases

Operating Temperature

-100° to -400° F (-73° to -204°C)

Operating Pressure

80 PSI (5.5 bar) Standard or 60 PSI (4.1 bar)

Materials

Generator Body: Anodized Aluminum

Supply Line

1/2" OD (12mm)

Vacuum Line

1/2" OD (12mm), preferred 3/4" (22mm) for lines exceeding 3' (1M)

Mounting Holes

Mounting holes accept 10-32[M5] screws

Performance Level Designations

"L", "X" 0-10"Hg [0 to 339mbar] for low vacuum/high flow applications

"M", "Y" 0-20"Hg [0 to 677mbar] for medium vacuum/high flow applications

"H", "Z" 0-28"Hg [0 to 948mbar] for high vacuum/standard flow applications

Control Valve

12V or 24V normally closed or 24V normally open

Product options

Standard (NVP90)

Valve controlled (NVP90V)

Multi-port (NVP90M)



Standard Models

Part number	Max. Vacuum Level	Max. Vacuum Flow	Air Consumption	Silencer
NVP90-300M-S27A00	20"Hg	20.00 SCFM	12.50 SCFM	NFA-51-.500 Silencer
NVP90-300H-S27A00	28"Hg	20.00 SCFM	22.00 SCFM	NFA-51-.500 Silencer
NVP90-350M-S27A00	20"Hg	28.00 SCFM	22.00 SCFM	NFA-51-.500 Silencer
NVP90-350H-S27A00	28"Hg	28.00 SCFM	28.00 SCFM	NFA-51-.500 Silencer

Accessories

Option selector

Series	Substitute	NVP 90-	-S	A	Accessories	Substitute
NVP (Imperial Thread)					Extra Ports / No Accessories	A00
NVPM (Metric Thread)	M				Extra Ports / NVG-150-GF	A38
Vacuum Flow Level	Substitute				Silencers	Substitute
Venturi Cartridge 300	300			None	S00	
Venturi Cartridge 350	350			NFA-51-.500 (72dB)	S27	
Vacuum Level	Substitute			NFA-51-.500 - No Elbow (72dB)	S37	
10"Hg @ 80PSI (Standard)	L			NST8B (76dB)	S11	
20"Hg @ 80PSI (Standard)	M			NST8B - No Elbow (76dB)	S31	
28"Hg @ 80PSI (Standard)	H					
10"Hg @ 60PSI	X					
20"Hg @ 60PSI	Y					
28"Hg @ 60PSI	Z					

Accessories

Standard Models	Inline Fitting	Swivel Elbow Fitting
NVP90-300M-S27A00	124250738	124470738
NVP90-300H-S27A00	124250738	124470738
NVP90-350M-S27A00	124250738	124470738
NVP90-350H-S27A00	124250738	124470738

*Proper selection of vacuum cups depends on the application. Cups are available in various durometers, colors and materials. If you do not see what you are looking for, please consult factory
 *The fittings, cups, and spring levelers listed are a small selection of possible options please refer to the specific catalog section

Dimensions inches (mm)

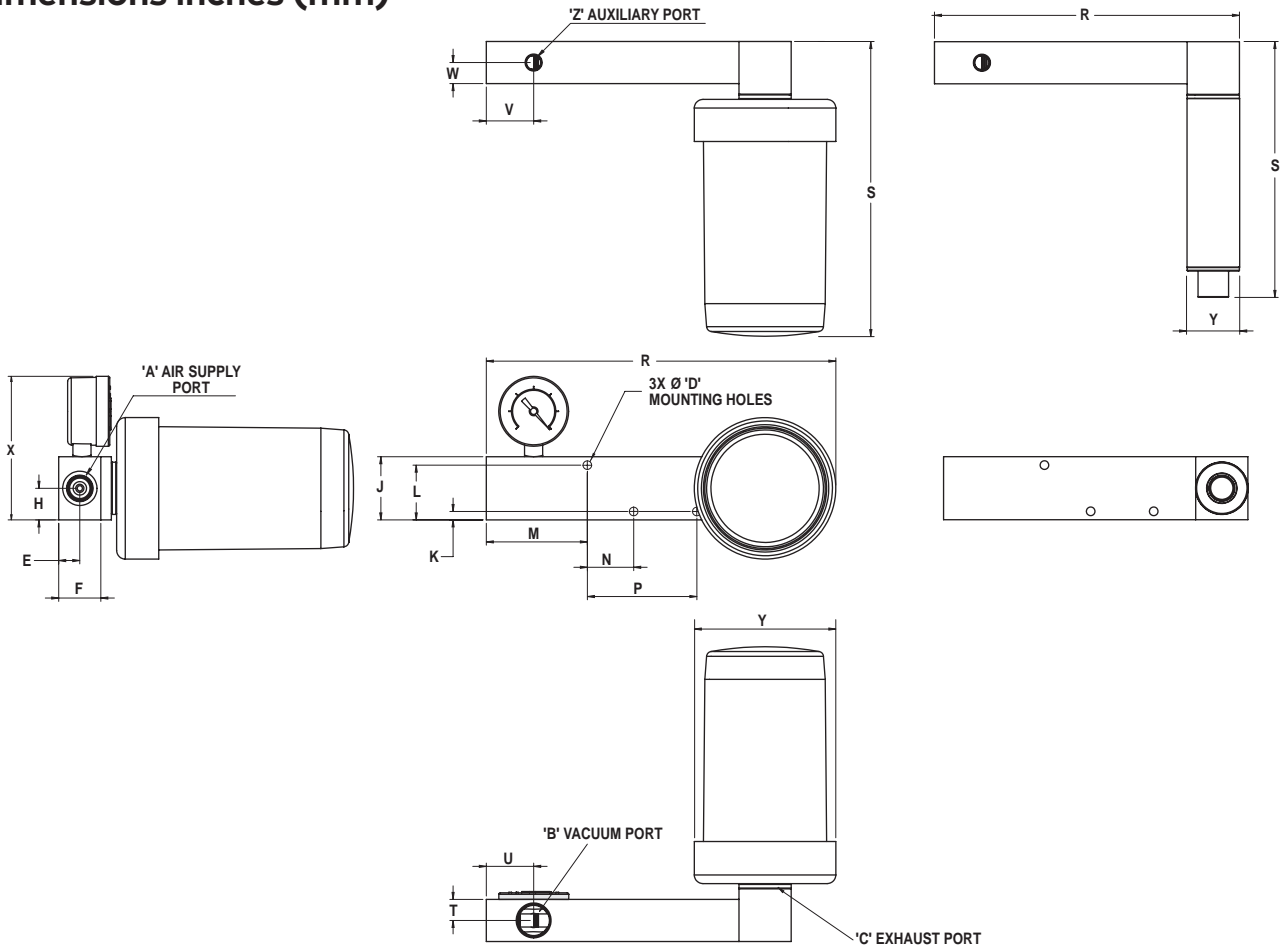

Model	Units	A	B	C	D	E	F	H	J	K	L	M	N	P	R	S	T	U	V	W	X	Y	Z
NVP90-3***-S27A38	Imperial	3/8 NPTF	1/2 NPTF	1/2 NPTF	0.21	0.50	1.00	0.75	1.50	0.20	1.10	2.40	1.10	2.60	8.30	7.00	0.50	1.13	1.13	0.50	3.36	3.41	1/8 NPTF
NVP90-3***-S11A00	Imperial	3/8 NPTF	1/2 NPTF	1/2 NPTF	0.21	0.50	1.00	0.75	1.50	0.20	1.10	2.40	1.10	2.60	7.24	6.07	0.50	1.13	1.13	0.50	3.36	1.25	1/8 NPTF
NVPM90-3***-S27A38	(Metric)	(G 3/8)	(G 1/2)	(G 1/2)	(5.3)	(12.7)	(25.4)	(19.1)	(38.1)	(5.1)	(27.9)	(61.0)	(27.9)	(66.0)	(298.4)	(177.8)	(12.7)	(28.6)	(28.6)	(12.7)	(86.6)	(86.6)	(G 1/8)
NVPM90-3***-S11A00	(Metric)	(G 3/8)	(G 1/2)	(G 1/2)	(5.3)	(12.7)	(25.4)	(19.1)	(38.1)	(5.1)	(27.9)	(61.0)	(27.9)	(66.0)	(268.2)	(154.2)	(12.7)	(28.6)	(28.6)	(12.7)	(86.6)	(31.8)	(G 1/8)



Dimensions inches (mm)

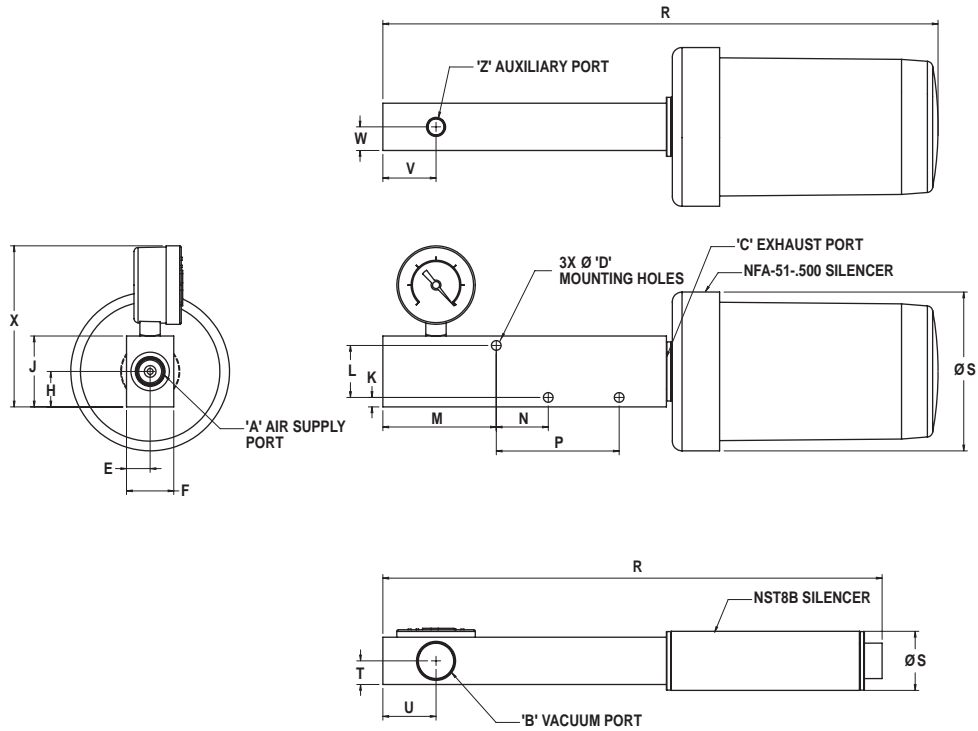

Model	Units	A	B	C	D	E	F	H	J	K	L	M	N	P	R	S	T	U	V	W	X	Y
NVP90-3***-S27A38	Imperial	3/8 NPTF	1/2 NPTF	1/2 NPTF	0.21	0.50	1.00	0.75	1.50	0.20	1.10	2.40	1.10	2.60	11.75	3.36	0.50	1.13	1.13	0.50	3.41	1/8 NPTF
NVP90-3***-S11A00	Imperial	3/8 NPTF	1/2 NPTF	1/2 NPTF	0.21	0.50	1.00	0.75	1.50	0.20	1.10	2.40	1.10	2.60	10.56	1.25	0.50	1.13	1.13	0.50	3.41	1/8 NPTF
NVPM90-3***-S27A38	(Metric)	(G 3/8)	(G 1/2)	(G 1/2)	(5.3)	(12.7)	(25.4)	(19.1)	(38.1)	(5.1)	(27.9)	(61.0)	(27.9)	(66.0)	(298.4)	(85.3)	(12.7)	(28.6)	(28.6)	(12.7)	(86.6)	(G 1/8)
NVPM90-3***-S11A00	(Metric)	(G 3/8)	(G 1/2)	(G 1/2)	(5.3)	(12.7)	(25.4)	(19.1)	(38.1)	(5.1)	(27.9)	(61.0)	(27.9)	(66.0)	(268.2)	(31.8)	(12.7)	(28.6)	(28.6)	(12.7)	(86.6)	(G 1/8)

NVP90V



- » High Productivity – non-clogging design reduces downtime
- » Strong hold – powerful vacuum up to 28"Hg [948mbar]
- » Mounts Easily – compact and lightweight
- » Fast Response – installs close to vacuum point
- » Efficient – minimal air consumption
- » Reliable operation – straight-through design with no moving parts

Technical Data

Fluid
Filtered (100 Micron) unlubricated, non-corrosive dry gases

Operating Temperature
-100° to -400° F (-73° to -204°C)
20° to 120° F (-7° to 49°C) (Valve)

Operating Pressure
80 PSI (5.5 bar) Standard or 60 PSI (4.1 bar)

Materials
Generator Body: Anodized Aluminum

Supply Line
1/2" OD (12mm)

Vacuum Line
1/2" OD (12mm), preferred 3/4" (22mm) for lines exceeding 3' (1M)

Mounting Holes
Mounting holes accept 10-32[M5] screws

Electrical
24V -5% to 10% (VC/VO option)
12V -5% to 10% (VC option)

Power Consumption (Watts)
1.6 watts

Response Times
8 milliseconds

Cycle Rate
45 cycles/second

Electrical Connection
11.8" Flying Lead

LED Indicator with Manual Override
Yes

Control
12V (VC option) or 24V normally closed (VA option) or 24V normally open (VB option)

Performance Level Designations
"L", "X" 0-10"Hg [0 to 339mbar] for low vacuum/high flow applications
"M", "Y" 0-20"Hg [0 to 677mbar] for medium vacuum/high flow applications
"H", "Z" 0-28"Hg [0 to 948mbar] for high vacuum/standard flow applications

Product options
Standard (NVP90)
Valve controlled (NVP90V)
Multi-port (NVP90M)
Air Saver (NVP90C)



Standard Models

Part number	Valve	Max. Vacuum Level	Max. Vacuum Flow	Air Consumption	Silencer
NVP90VA-300M-S27A00	NC 24V	20"Hg	20.00 SCFM	12.50 SCFM	NFA-51-.500 Silencer
NVP90VA-300H-S27A00	NC 24V	28"Hg	20.00 SCFM	22.00 SCFM	NFA-51-.500 Silencer
NVP90VA-350M-S27A00	NC 24V	20"Hg	28.00 SCFM	22.00 SCFM	NFA-51-.500 Silencer
NVP90VA-350H-S27A00	NC 24V	28"Hg	28.00 SCFM	28.00 SCFM	NFA-51-.500 Silencer

Accessories

Option selector

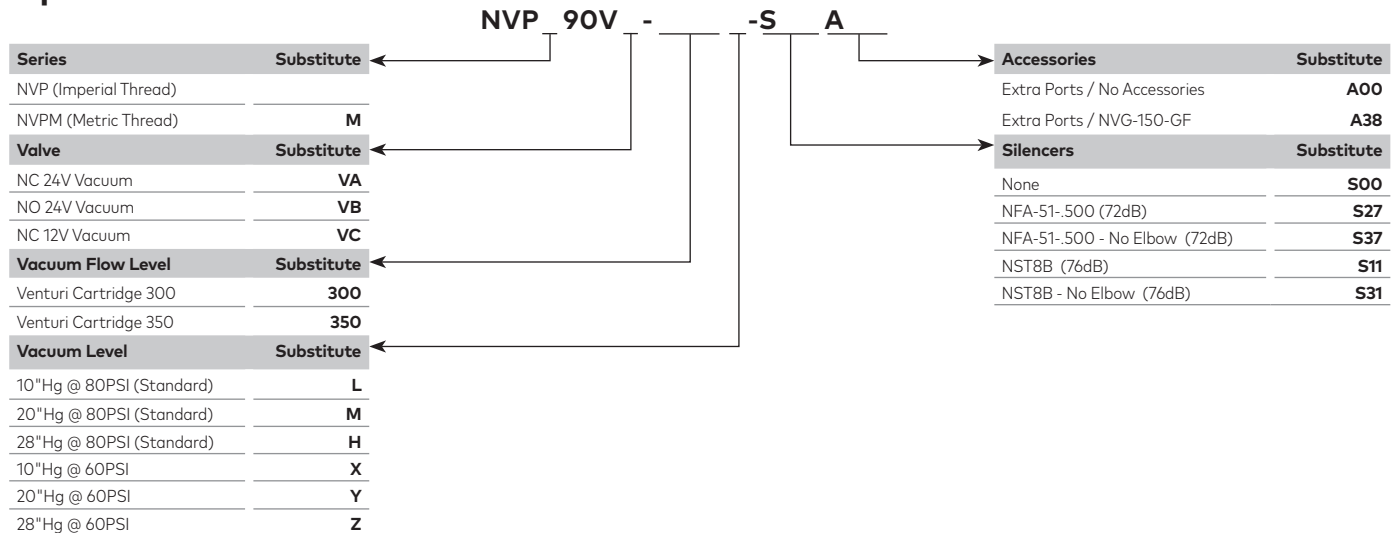



Accessories

Standard Models	Inline Fitting	Swivel Elbow Fitting
NVP90-300M-S27A00	124250738	124470738
NVP90-300H-S27A00	124250738	124470738
NVP90-350M-S27A00	124250738	124470738
NVP90-350H-S27A00	124250738	124470738

*Proper selection of vacuum cups depends on the application. Cups are available in various durometers, colors and materials. If you do not see what you are looking for, please consult factory
 *The fittings, cups, and spring levelers listed are a small selection of possible options please refer to the specific catalog section

Dimensions inches (mm)

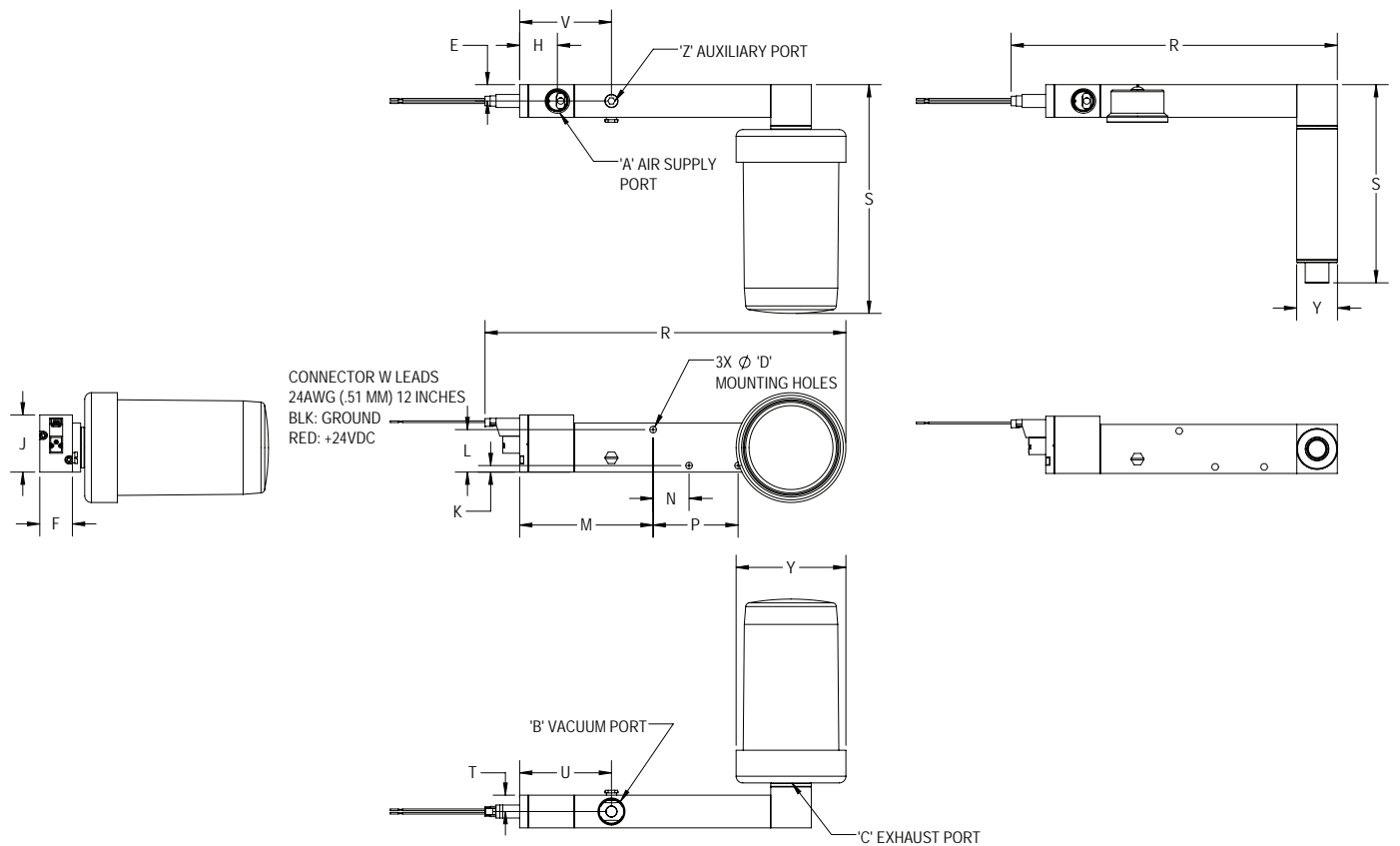

Model	Units	A	B	C	D	E	F	H	J	K	L	M	N	P	R	S	T	U	V	W	Z
NVP90VA-3***-S27A38	Imperial	3/8 NPTF	3/8 NPTF	3/8 NPTF	0.21	0.50	1.00	1.16	1.75	0.20	1.30	3.89	1.10	2.60	11.05	7.00	0.50	2.81	2.81	0.50	1/8 NPTF
NVP90VA-3***-S11A00	Imperial	3/8 NPTF	3/8 NPTF	3/8 NPTF	0.21	0.50	1.00	1.16	1.75	0.20	1.30	3.89	1.10	2.60	9.98	6.06	0.50	2.81	2.81	0.50	1/8 NPTF
NVPM90VA-3***-S27A38	(Metric)	(G 3/8)	(G 3/8)	(G 3/8)	(5.3)	(12.7)	(25.4)	(29.5)	(44.5)	(5.1)	(33.)	(98.8)	(27.9)	(66.0)	(280.7)	(177.8)	(12.7)	(71.4)	(71.4)	(12.7)	(G 1/8)
NVPM90VA-3***-S11A00	(Metric)	(G 3/8)	(G 3/8)	(G 3/8)	(5.3)	(12.7)	(25.4)	(29.5)	(44.5)	(5.1)	(33.)	(98.8)	(27.9)	(66.0)	(253.5)	(153.9)	(12.7)	(71.4)	(71.4)	(12.7)	(G 1/8)

NVP90M

Multi-port



- » Multi-port version - distribute vacuum to multiple locations
- » High Productivity – non-clogging design reduces downtime
- » Strong hold – powerful vacuum up to 28" Hg [948mbar]
- » Mounts Easily – compact and lightweight
- » Fast Response – installs close to vacuum point
- » Efficient – minimal air consumption
- » Reliable operation – straight-through design with no moving parts

Technical Data

Fluid

Filtered (100 Micron) unlubricated, non-corrosive dry gases

Operating Temperature

-100° to -400° F (-73° to -204°C)
20° to 120° F (-7° to 49°C) (Valve)

Operating Pressure

80 PSI (5.5 bar) Standard or
60 PSI (4.1 bar)

Materials

Generator Body: Anodized Aluminum

Supply Line

1/2" OD (12mm)

Vacuum Line

1/2" OD (12mm), preferred
3/4" (22mm) for lines exceeding
3' (1M)

Mounting Holes

Mounting holes accept
10-32[M5] screws

Electrical

24V -5% to 10% (VA,VB option)
12V -5% to 10% (VC option)

Power Consumption (Watts)

1.6 watts

Response Times

8 milliseconds

Cycle Rate

45 cycles/second

Average Valve Life

50 million cycles

Electrical Connection

11.8" Flying Lead

LED Indicator with Manual Override

Yes

Control Valve

12V (VC option) or 24 normally closed (VA option) or 24V normally open (VB option)

Performance Level Designations

"L" 0-10"Hg [0 to 339mbar]

for low vacuum/high flow applications

"M" 0-20"Hg [0 to 677mbar]

for medium vacuum/high flow applications

"H" 0-28"Hg [0 to 948mbar]

for high vacuum/standard flow applications

Product options

Standard (NVP90)

Valve controlled (NVP90V)

Multi-port (NVP90M)

Air Saver (NVP90C)



Standard Models

Accessories

Part number	Valve	Max. Vacuum Level	Max. Vacuum Flow	Air Consumption	Silencer
NVP90M0-300M-S11A38	None	20"Hg	20.00 SCFM	12.50 SCFM	NST8B Silencer
NVP90M0-300H-S11A38	None	28"Hg	20.00 SCFM	22.00 SCFM	NST8B Silencer
NVP90M0-350M-S11A38	None	20"Hg	28.00 SCFM	22.00 SCFM	NST8B Silencer
NVP90M0-350H-S11A38	None	28"Hg	28.00 SCFM	28.00 SCFM	NST8B Silencer
NVP90M0-300M-S11A38	NC 24V	20"Hg	20.00 SCFM	12.50 SCFM	NST8B Silencer
NVP90M0-300H-S11A38	NC 24V	28"Hg	20.00 SCFM	22.00 SCFM	NST8B Silencer
NVP90M0-350M-S11A38	NC 24V	20"Hg	28.00 SCFM	22.00 SCFM	NST8B Silencer
NVP90M0-350H-S11A38	NC 24V	28"Hg	28.00 SCFM	28.00 SCFM	NST8B Silencer

NVP90M

Multi-port



Option selector

Series	Substitute	NVP 90M -	-S11A	Accessories	Substitute
NVP (Imperial Thread)				Extra Ports / NVG-150-GF	A38
NVPM (Metric Thread)	M			Extra Ports / NVTMV-QD-6 / NVG-150-GF	A22
Valve	Substitute			Extra Ports / NVSMN-QD-6 / NVG-150-GF	A24
Multi-Port, No Valve	MO			Extra Ports / NVSMP-QD-6 / NVG-150-GF	A26
Multi-Port, NC 24V Vacuum	MA			Silencers	
Multi-Port, NO 24V Vacuum	MB			NST8B (76dB)	S11
Multi-Port, NC 12V Vacuum	MC				
Vacuum Flow Level	Substitute				
Venturi Cartridge 300	300				
Venturi Cartridge 350	350				
Vacuum Level	Substitute				
10"Hg @ 80PSI (Standard)	L				
20"Hg @ 80PSI (Standard)	M				
28"Hg @ 80PSI (Standard)	H				
10"Hg @ 60PSI	X				
20"Hg @ 60PSI	Y				
28"Hg @ 60PSI	Z				

Accessories

Standard Models	Inline Fitting	Swivel Elbow Fitting	Vacuum Swivel Fitting
			
NVP90M0-300M-S11A00	124250738	124470738	124470748
NVP90M0-300H-S11A00	124250738	124470738	124470748
NVP90M0-350M-S11A00	124250738	124470738	124470748
NVP90M0-350H-S11A00	124250738	124470738	124470748

*Proper selection of vacuum cups depends on the application. Cups are available in various durometers, colors and materials. If you do not see what you are looking for, please consult factory
 *The fittings, cups, and spring levelers listed are a small selection of possible options please refer to the specific catalog section

NVP90M

Multi-port



Dimensions inches (mm)

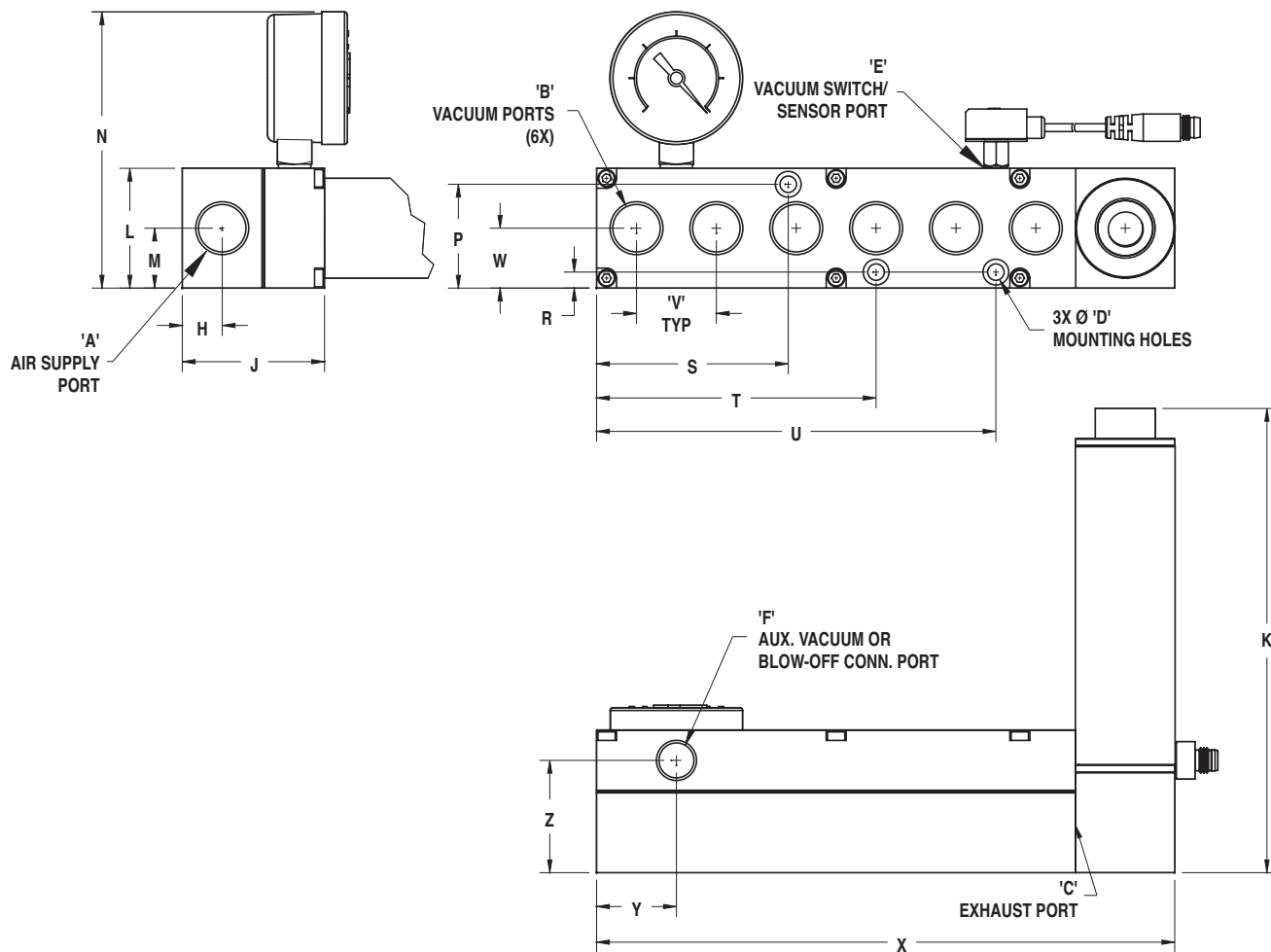

Model	Units	A	B	C	D	E	F	H	J	K	L	M	N	P	R	S	T	U	V	W	X	Y	Z
NVP90M0-3***-S11A38	Imperial	3/8 NPTF	3/8 NPTF	1/2 NPTF	0.21	10-32	1/8 NPTF	0.50	1.78	6.07	1.50	0.75	3.41	1.30	0.20	2.40	3.50	5.00	1.00	0.75	7.25	1.00	1.41
NVPM90M0-3***-S11A38	(Metric)	(G 3/8)	(G 3/8)	(G 1/2)	(5.3)	M-5	(G 1/8)	(12.7)	(45.2)	(154.2)	(38.1)	(19.1)	(86.6)	(33.0)	(5.1)	(61.0)	(88.9)	(127.0)	(25.4)	(19.1)	(184.2)	(25.4)	(35.8)



Dimensions inches (mm)

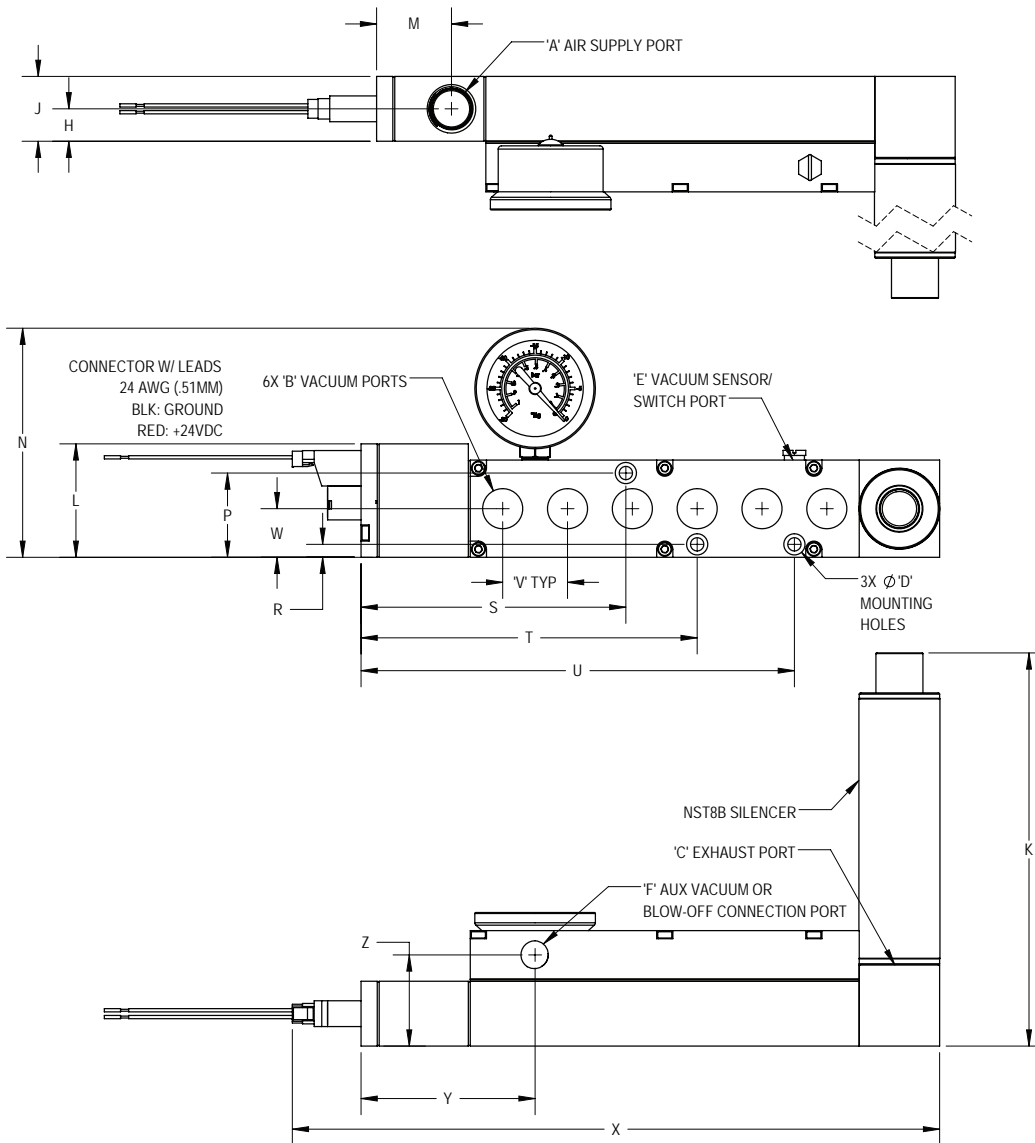

Model	Units	A	B	C	D	E	F	H	J	K	L	M	N	P	R	S	T	U	V	W	X	Y	Z
NVP90MA-3***-S11A38	Imperial	3/8 NPTF	3/8 NPTF	1/2 NPTF	0.21	10-32	1/8 NPTF	0.50	1.00	6.06	1.75	1.16	3.53	1.30	0.20	4.06	5.19	6.69	1.00	0.75	9.99	2.69	1.41
NVPM90MA-3***-S11A38	(Metric)	(G 3/8)	(G 3/8)	(G 1/2)	(5.3)	M5	(G 1/8)	(12.7)	(25.4)	(153.9)	(44.5)	(29.5)	(89.7)	(33.0)	(5.1)	(103.1)	(131.8)	(169.9)	(25.4)	(19.1)	(253.7)	(68.3)	(35.8)

NVP90C

Air Saver



1

MODULAR VACUUM GENERATORS

- » Energy efficient – compressed air on only when needed, automatic shut-off
- » High Productivity – non-clogging design reduces downtime
- » Strong hold – powerful vacuum up to 28"Hg [948mbar]
- » Mounts Easily – compact and lightweight
- » Fast Response – installs close to vacuum point
- » Efficient – minimal air consumption
- » Reliable operation – straight-through design with no moving parts

Technical Data

Fluid

Filtered (100 Micron) unlubricated, non-corrosive dry gases

Operating Temperature

-30° to -250° F (-34° to -121°C)

Operating Pressure

80 PSI (5.5 bar) Standard or 60 PSI (4.1 bar)

Materials

Generator Body: Anodized Aluminum

Supply Line

1/2" OD (12mm)

Vacuum Line

1/2" OD (12mm)

Mounting Holes

Mounting holes accept 10-32[M5] screws

Performance Level

Designations

"M", "Y" 0-20"Hg [0 to 677mbar] for medium vacuum/high flow applications

"H", "Z" 0-28"Hg [0 to 948mbar] for high vacuum/standard flow applications

Generator Selection

1. Determine the desired evacuation time (speed)
2. Calculate the total volume of air to be evacuated in the system including vacuum lines, vessel/cavity size, cups, etc.
3. Determine the desired vacuum level, "Hg/mbar Application
ex.: Evacuate 2 cu.ft. of air in 1 minute (60 sec) at a vacuum level of 21"Hg
Formula: Time (60 sec)/Cu. ft (2) = 30 seconds per cu.ft. (evacuation speed)

Product options

- Standard (NVP90)
- Valve controlled (NVP90V)
- Multi-port (NVP90M)
- Air Saver (NVP90C)



Standard Models

Part number	Max. Vacuum Level	Max. Vacuum Flow	Air Consumption	Silencer
NVP90CO-300M-S11A38	20"Hg	20.00 SCFM	12.50 SCFM	NST8B Silencer
NVP90CO-300H-S11A38	28"Hg	20.00 SCFM	22.00 SCFM	NST8B Silencer
NVP90CO-350M-S11A38	20"Hg	28.00 SCFM	22.00 SCFM	NST8B Silencer
NVP90CO-350H-S11A38	28"Hg	28.00 SCFM	28.00 SCFM	NST8B Silencer

Accessories



Option selector

NVP 90C0- -S27A38

Series	Substitute
NVP (Imperial Thread)	
NVPM (Metric Thread)	M
Vacuum Flow Level	Substitute
Venturi Cartridge 300	300
Venturi Cartridge 350	350
Vacuum Level	Substitute
20"Hg @ 80PSI (Standard)	M
28"Hg @ 80PSI (Standard)	H
20"Hg @ 60PSI	Y
28"Hg @ 60PSI	Z

Accessories	Substitute
Extra Ports / NVG-150-GF	A38
Silencers	
NFA-51-.500 (72dB)	S27

Dimensions inches (mm)

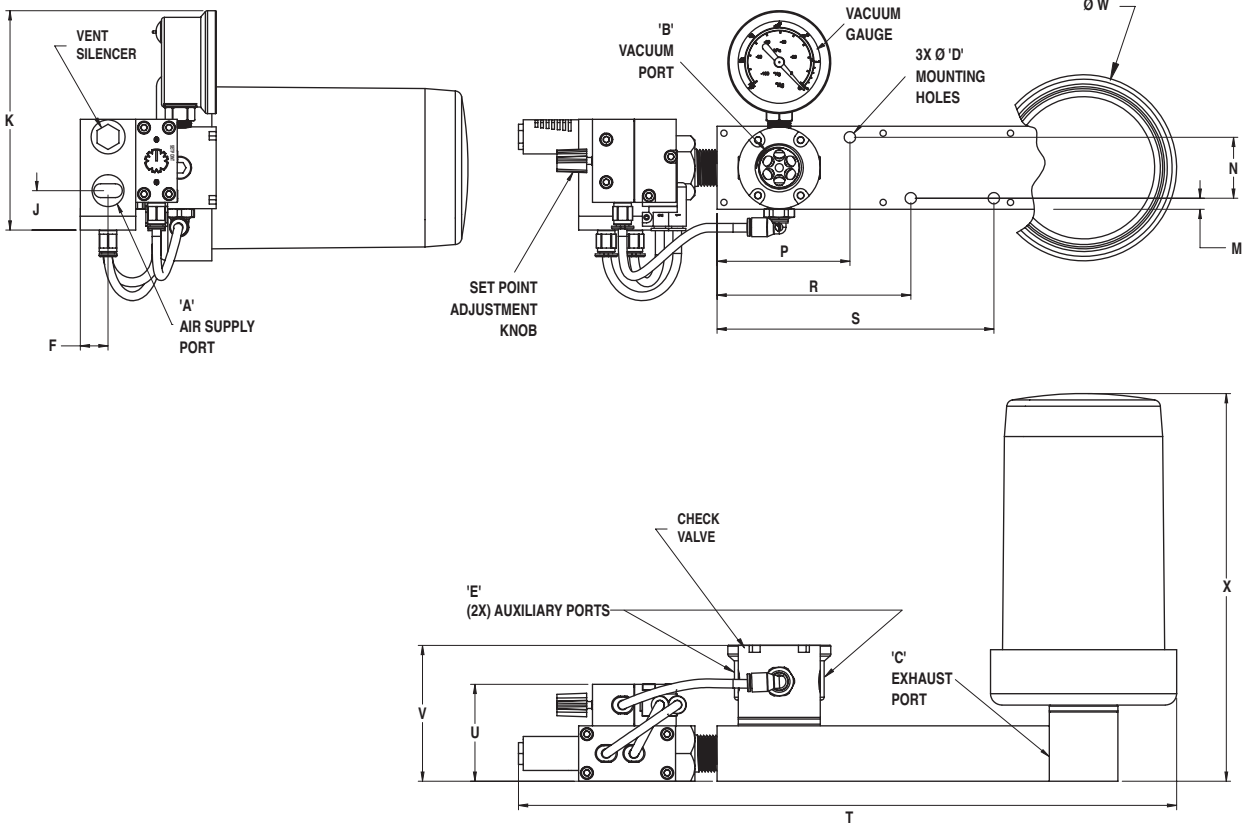

Model	Units	A	B	C	D	E	F	J	K	M	N	P	R	S	T	U	V	W	X
NVP90M0-3***-S27A38	Imperial	3/8 NPTF	1/2 NPTF	1/2 NPTF	0.21	1/8 NPTF	0.50	0.74	3.90	0.20	1.30	2.40	3.50	5.00	11.20	1.72	2.30	3.23	7.00
NVPM90M0-3***-S27A38	(Metric)	(G 3/8)	(G 1/2)	(G 1/2)	(5.3)	(G 1/8)	(12.7)	(18.9)	(99.0)	(5.1)	(33.0)	(61.0)	(88.9)	(127.0)	(284.5)	(43.7)	(58.4)	(82.0)	(177.8)

Performance Data

Model	Air Consumption SCFM (L/min)	Vacuum Level "Hg (mbar)	0"Hg (0)	3"Hg (102)	6"Hg (203)	9"Hg (305)	10"Hg (339)	12"Hg (406)	15"Hg (508)	18"Hg (609)	20"Hg (677)	21"Hg (711)	24"Hg (813)	27"Hg (914)	28"Hg (948)
300M	12.50 (354.0)	Vacuum Flow SCFM (L/min)	20.00 (566.3)	19.00 (530.8)	16.30 (461.6)	13.80 (390.8)	- (-)	8.10 (229.4)	5.50 (155.7)	3.30 (93.4)	0.00 (0.0)	- (-)	- (-)	- (-)	- (-)
		Evacuation time (seconds)	0.00 (0.0)	0.00 (0.0)	0.00 (0.0)	1.10 (0.0)	- (-)	1.80 (0.1)	2.70 (0.1)	4.60 (0.2)	8.70 (0.3)	- (-)	- (-)	- (-)	- (-)
350M	22.00 (623.0)	Vacuum Flow SCFM (L/min)	28.00 (792.9)	24.00 (679.6)	19.40 (549.3)	16.80 (475.7)	- (-)	14.50 (410.6)	11.20 (317.1)	4.80 (135.9)	0.00 (0.0)	- (-)	- (-)	- (-)	- (-)
		Evacuation time (seconds)	0.00 (0.0)	0.00 (0.0)	0.00 (0.0)	1.00 (0.0)	- (-)	1.50 (0.1)	2.10 (0.1)	4.30 (0.2)	8.40 (0.3)	- (-)	- (-)	- (-)	- (-)
300H	22.00 (623.0)	Vacuum Flow SCFM (L/min)	20.00 (566.3)	17.00 (481.4)	14.00 (396.4)	12.70 (359.6)	- (-)	12.00 (339.8)	10.00 (238.2)	7.40 (209.5)	- (-)	4.90 (138.8)	2.70 (76.5)	1.30 (36.8)	0.00 (0.0)
		Evacuation time (seconds)	0.00 (0.0)	0.00 (0.0)	0.80 (0.0)	1.20 (0.0)	- (-)	2.00 (0.1)	2.80 (0.1)	3.90 (0.1)	- (-)	5.90 (0.2)	11.10 (0.4)	32.70 (1.2)	60.00 (2.1)
350H	28.00 (792.9)	Vacuum Flow SCFM (L/min)	28.00 (792.3)	22.00 (623.0)	18.70 (529.5)	15.90 (450.2)	- (-)	14.50 (410.6)	11.80 (334.1)	8.10 (229.4)	- (-)	5.70 (161.4)	4.50 (127.4)	2.25 (63.7)	0.00 (0.0)
		Evacuation time (seconds)	0.00 (0.0)	0.00 (0.0)	0.00 (0.0)	1.20 (0.0)	- (-)	1.90 (0.1)	2.30 (0.1)	3.40 (0.1)	- (-)	5.30 (0.2)	8.80 (0.3)	26.00 (0.9)	44.00 (1.6)

Evacuation time in seconds based on 1 cubic foot volume / "Hg (1 Liter Volume / mbar)



Performance Data

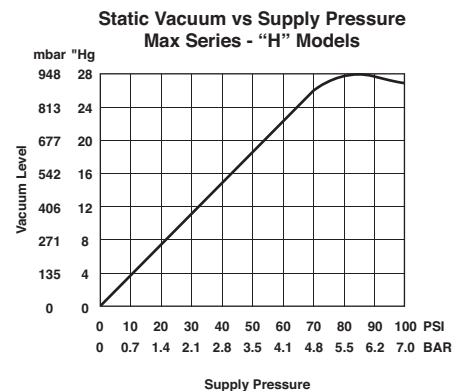
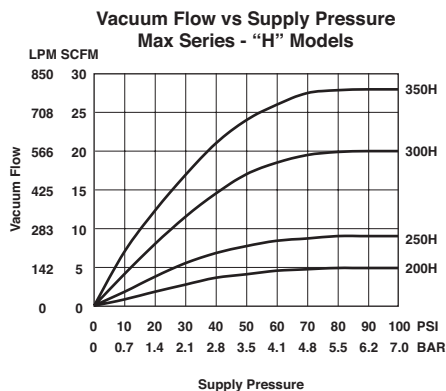
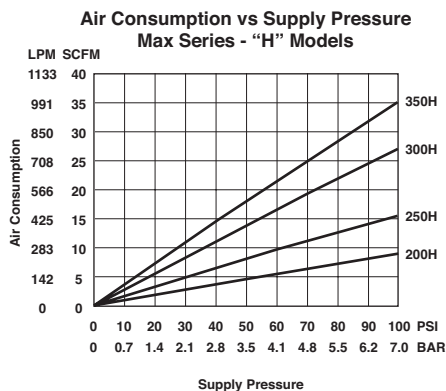
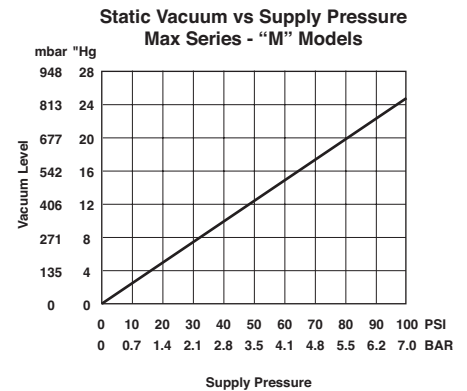
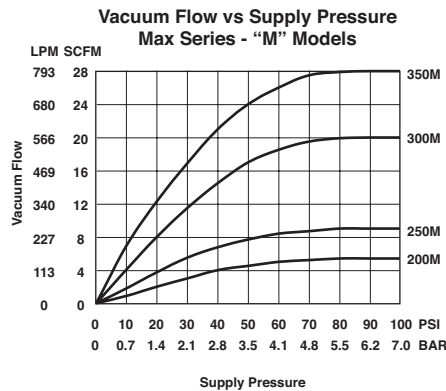
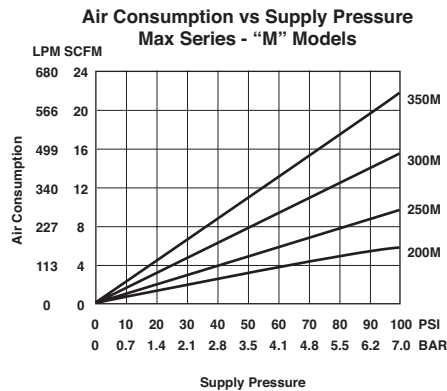
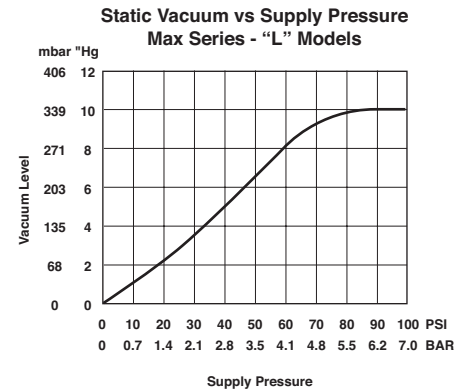
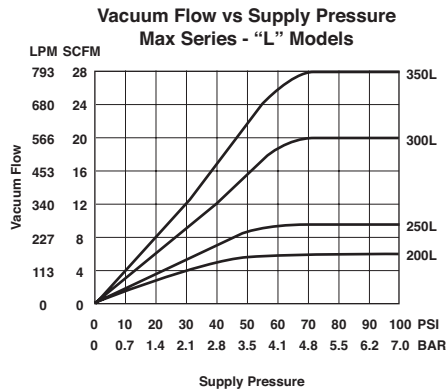
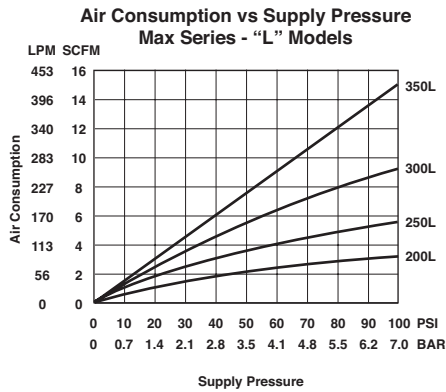

Warnings

Improper selection, misuse, age or malfunction of components used in systems can cause failure in various modes. The system designer is warned to consider the failure modes of all component parts and to provide adequate safeguards to prevent personal injury or damage to equipment or property in the event of such failure modes. System designers and end users are cautioned to consult instruction sheets and specifications available from the factory. The system designer/end user is responsible for verifying that all requirements for the application are met.

Warranty

The products described herein are warranted subject to seller's Standard Terms and Condition of Sale, available at seller's website.

NHVP

High Vacuum Generator



- » High Productivity – non-clogging design reduces downtime
- » Strong hold – powerful vacuum up to 29.5" Hg [999mbar]
- » Mounts Easily – compact and lightweight
- » Fast Response – installs close to vacuum point
- » Efficient – minimal air consumption
- » Reliable operation – straight-through design with no moving parts

Technical Data

Fluid
Filtered (50 Micron) unlubricated, non-corrosive dry gases

Operating Temperature
-30° to ~250° F (-34° to ~121°C)

Operating Pressure
80 PSI (5.5 bar) Standard or

Materials
Generator Body: Anodized Aluminum

Supply / Vacuum Line
3/8" OD (10mm) tube for sizes 100 / 200
1/2" OD (12mm) tube for size 300

Mounting Holes
Mounting holes accept 4-40[M3] screws for size 100
Mounting holes accept 10-32[M5] screws for sizes 200 / 300



Standard Models

Part Number	Max. Vacuum Level	Max. Vacuum Flow	Air Consumption	Silencer
NHVP-100-S05A00	29.5"Hg	1.30 SCFM	4.90 SCFM	NST4 Silencer
NHVP-200-S10A00	29.5"Hg	3.45 SCFM	8.60 SCFM	NST8A Silencer
NHVP-300-S11A00	29.5"Hg	6.00 SCFM	22.00 SCFM	NST8B Silencer

Accessories

Option selector

Series	Substitute	Accessories
NHVP (Imperial Thread)		Sensor & Gauge Ports / No Accessories A00
NHVP (Metric Thread)	M	Sensor & Gauge Ports / NVTMV-QD-6 A02
Size	Substitute	Sensor & Gauge Ports / NVSMN-QD-6 A04
NHVP 100	100	Sensor & Gauge Ports / NVSMP-QD-6 A06
NHVP 200	200	Sensor & Gauge Ports / NVTMV-QD-6 / NVG-150-CBM A32
NHVP 300	300	Sensor & Gauge Ports / NVSMN-QD-6 / NVG-150-CBM A34
Silencer for NHVP-100		Sensor & Gauge Ports / NVSMP-QD-6 / NVG-150-CBM A36
NST4 (68dB)	S05	Sensor & Gauge Ports / NVG-150-CBM A39
Silencer for NHVP-200		Sensor Port Only / NVTMV-QD-6 A42
NST8A (74dB)	S10	Sensor Port Only / NVSMN-QD-6 A44
Silencer for NHVP-300		Sensor Port Only / NVSMP-QD-6 A46
NST8B (76dB)	S11	Gauge Port Only / NVG-150-CBM A49
		Sensor Port Only A97
		Gauge Port Only A98
		No Ports / No Accessories A99

Accessories

Standard Models	Inline Fitting	Swivel Elbow Fitting	Vacuum Fitting	Flat Cup
NVP80-200M-S08A00	124250628	124470618	NVCF5-38M	NUC040****
NVP80-200H-S08A00	124250628	124470618	NVCF5-38M	NUC040****
NVP80-250M-S10A00	124250628	124470618	NVCF5-38M	NUC040****
NVP80-250H-S10A00	124250628	124470618	NVCF5-38M	NUC040****

*Proper selection of vacuum cups depends on the application. Cups are available in various durometers, colors and materials. If you do not see what you are looking for, please consult factory
 *The fittings, cups, and spring levelers listed are a small selection of possible options please refer to the specific catalog section





Dimensions inches (mm)

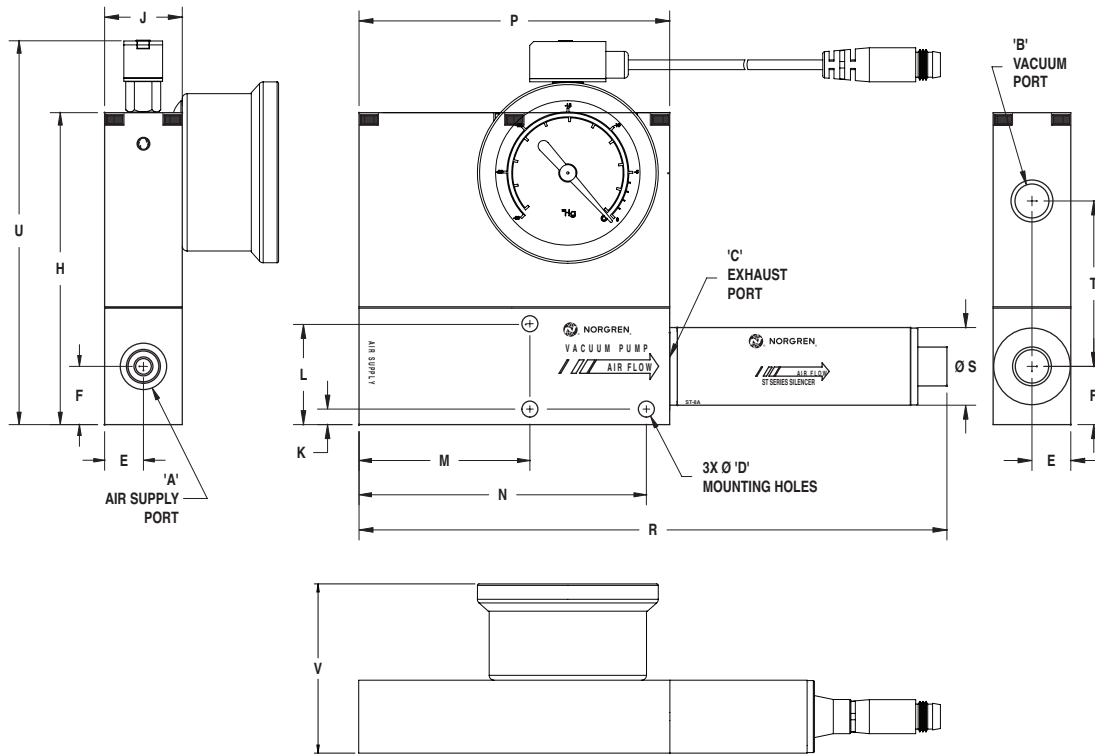

Model	Units	A	B	C	D	E	F	H	J	K	L	M	N	P	R	S	T	U	V
NHVP-100-S05A38	Imperial	1/4 NPTF	1/8 NPTF	1/4 NPTF	0.12	0.38	0.38	2.28	0.75	0.09	0.67	1.78	N/A	3.20	5.06	0.75	1.28	3.02	2.00
NHVP-200-S10A38	Imperial	1/4 NPTF	1/4 NPTF	1/2 NPTF	0.21	0.50	0.75	4.02	1.00	0.20	N/A	2.20	3.70	4.00	7.57	1.00	2.13	4.76	2.00
NHVP-300-S11A38	Imperial	3/8 NPTF	1/4 NPTF	1/2 NPTF	0.21	0.50	0.75	4.02	1.00	0.20	N/A	2.50	4.00	5.00	9.81	1.25	2.12	4.76	2.00
NHVP-100-S05A38	(Metric)	(G 1/4)	(G 1/8)	(G 1/4)	(3.1)	(9.7)	(9.7)	(57.9)	(19.1)	(2.3)	(17.0)	(45.2)	N/A	(81.3)	(128.5)	(19.1)	(32.5)	(76.7)	(50.8)
NHVP-200-S10A38	(Metric)	(G 1/4)	(G 1/4)	(G 1/2)	(5.3)	(12.7)	(19.1)	(102.1)	(25.4)	(5.1)	N/A	(55.9)	(94.0)	(101.6)	(192.3)	(25.4)	(54.1)	(120.9)	(50.8)
NHVP-300-S11A38	(Metric)	(G 3/8)	(G 1/4)	(G 1/2)	(5.3)	(12.7)	(19.1)	(102.1)	(25.4)	(5.1)	N/A	(63.5)	(101.6)	(127.0)	(249.2)	(31.8)	(53.8)	(120.9)	(50.8)

Performance Data

Model	Air Consumption		Vacuum Level "Hg (mbar)	0"Hg	3"Hg	6"Hg	9"Hg	12"Hg	15"Hg	18"Hg	21"Hg	24"Hg	27"Hg	28"Hg
	SCFM (L/min)	"Hg (mbar)		(0)	(102)	(203)	(305)	(406)	(508)	(609)	(711)	(813)	(914)	(948)
NHVP-100	4.90 (138.8)	Vacuum Flow	1.30	1.20	1.10	1.00	0.90	0.90	0.90	0.80	0.60	0.30	0.00	
		SCFM (L/min)	(36.8)	(34.0)	(31.1)	(28.3)	(25.5)	(25.5)	(25.5)	(22.7)	(17.0)	(8.5)	(0.0)	
NHVP-200	8.60 (243.5)	Vacuum Flow	3.45	3.25	3.05	2.75	2.45	2.05	1.90	1.60	1.30	0.90	0.00	
		SCFM (L/min)	(97.7)	(92.0)	(86.4)	(77.9)	(69.4)	(58.0)	(53.8)	(45.3)	(36.8)	(25.5)	(0.0)	
NHVP-300	22.00 (623.0)	Vacuum Flow	6.00	5.10	4.70	4.40	4.10	3.60	3.00	2.60	1.80	0.90	0.00	
		SCFM (L/min)	(169.9)	(144.4)	(133.1)	(124.6)	(116.1)	(101.9)	(85.0)	(73.6)	(51.0)	(25.5)	(0.0)	
		Evacuation time (seconds)	0.00	6.50	12.30	18.90	32.50	40.00	52.50	72.50	98.00	135.50	281.30	
		Evacuation time (seconds)	(0.0)	(0.2)	(0.4)	(0.7)	(1.1)	(1.4)	(1.9)	(2.6)	(3.5)	(4.8)	(9.9)	
		Evacuation time (seconds)	0.00	2.30	3.80	6.50	10.20	14.10	20.00	29.50	44.00	67.50	125.00	
		Evacuation time (seconds)	(0.0)	(0.1)	(0.1)	(0.2)	(0.4)	(0.5)	(0.7)	(1.0)	(1.6)	(2.4)	(4.4)	
		Evacuation time (seconds)	0.00	1.20	2.10	3.40	5.20	7.70	11.50	16.30	24.00	39.50	98.10	
		Evacuation time (seconds)	(0.0)	(0.0)	(0.1)	(0.1)	(0.2)	(0.3)	(0.4)	(0.6)	(0.8)	(1.4)	(3.5)	

Cylindrical Venturi Vacuum Generators

The NJ-Series Venturi Vacuum Generators utilize a fixed cartridge venturi design and features a cylindrical design for ease of installation and mounting into in-line pneumatic plumbing.





Please note: These products represent only part of the Norgren vacuum range. If you can't see the option you require please contact us.

Cylindrical Venturi Vacuum Generators

<p>NJ Cylindrical Series - Vacuum level up to 28" Hg, flow up to 28.00 SCFM, robust design</p>  <p>Page 83</p>	<p>NVPI Cylindrical In-line Series - Vacuum level up to 24" Hg</p>  <p>Page 97</p>	<p>NMPVG Mini Cylindrical In-line Series - Vacuum level up to 27" Hg</p>  <p>Page 99</p>
--	--	--

NJ MIN SERIES



- » Durable – rugged aluminum body construction
- » Strong hold – powerful vacuum up to 27"Hg [914mbar]
- » Fast response – mounts in-line, close to vacuum point - no delay due to long plumbing lines
- » Efficient – minimal air consumption, provides instantaneous vacuum as needed
- » Safe operation – no electricity needed
- » Reliable operation – straight-through design with no moving parts

Technical Data

Fluid
Filtered (50 Micron) unlubricated, non-corrosive dry gasses

Operating Pressure
80 PSI (5.5 bar) Standard or 60 PSI (4.1 bar)

Operating Temperature
-100° to +400° F (-73° to +204°C)

Materials
Generator Body: Anodized Aluminum
Silencer Body: Brass

Supply / Vacuum Line
Min. 5/32" OD (4mm), 1/4" OD (6mm) tube preferred for lines exceeding 3' (1M)



Standard Models

Part Number	Max. Vacuum Level	Max. Vacuum Flow	Air Consumption	Accessories	Material
NJS-40UM-S32M01	27" Hg	0.23 SCFM	0.52 SCFM	NVCF2-1032M Silencer	Aluminum

Option selector

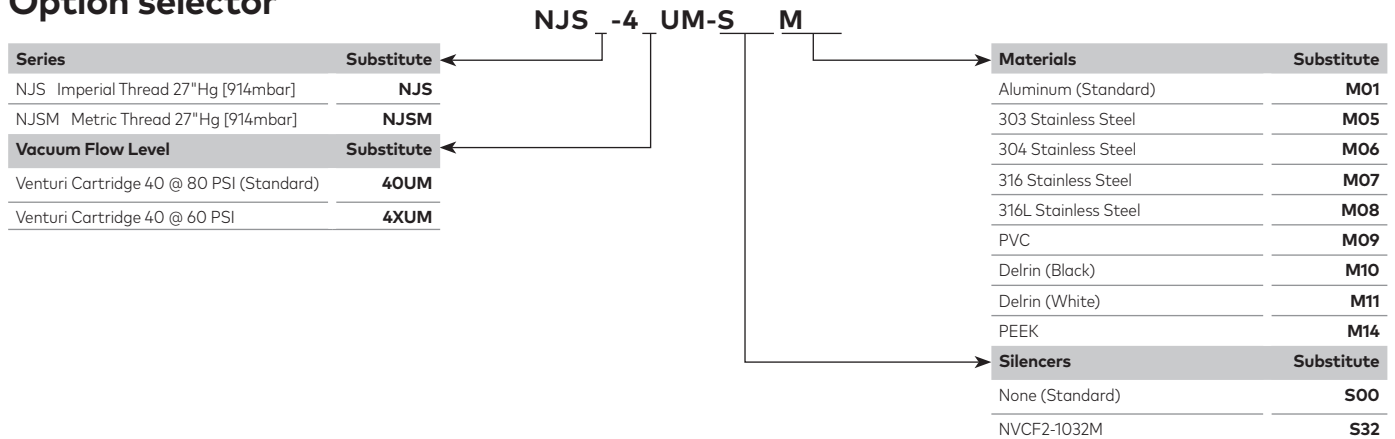

Accessories

Standard Models	Inline Fitting	Swivel Elbow Fitting	Vacuum Fitting	Flat Cup	Spring Leveler
NJS-40UM-S32M01	124250410	124470410	NVCF13-1032M	NFG*****	NVSL1.*
NJS-40UM-S32M05	124250410	124470410	NVCF13-1032M	NFG*****	NVSL1.*



Dimensions inches (mm)

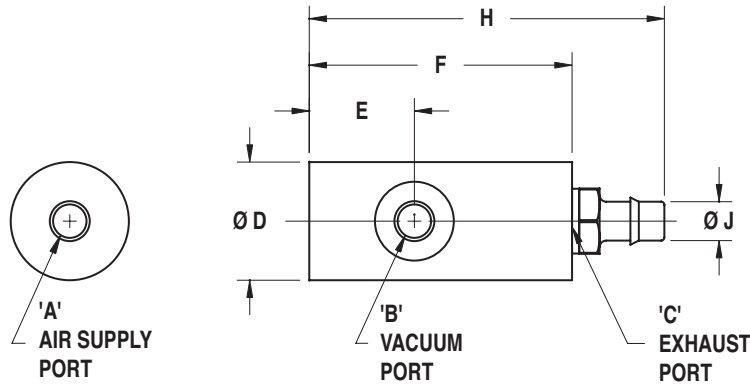

Model	Units	A	B	C	D	E	F	H	J
NJS-40UM-S00M01	Imperial	10-32F	10-32F	10-32F	0.56	0.45	1.45	N/A	N/A
NJS-40UM-S32M01	Imperial	10-32F	10-32F	10-32F	0.56	0.45	1.45	1.90	0.19
NJSM-40UM-S00M01	(Metric)	(M5)	(M5)	(M5)	(14.3)	(11.4)	(36.8)	-	-
NJSM-40UM-S32M01	(Metric)	(M5)	(M5)	(M5)	(14.3)	(11.4)	(36.8)	(48.3)	(4.7)

Performance Data

Model	Air Consumption		Vacuum Level											
	SCFM (L/min)	"Hg (mbar)	0"Hg (0)	3"Hg (102)	6"Hg (203)	9"Hg (305)	10"Hg (339)	12"Hg (406)	15"Hg (508)	18"Hg (609)	20"Hg (677)	21"Hg (711)	24"Hg (813)	27"Hg (914)
NJS-40UM	0.52 (14.70)	Vacuum Flow SCFM (L/min)	0.23 (6.5)	0.20 (5.7)	0.17 (4.8)	0.15 (4.2)	- (-)	0.13 (3.7)	0.10 (2.8)	0.08 (2.3)	- (-)	0.05 (1.4)	0.03 (0.8)	0.00 (0.0)
		Evacuation time (seconds)	0.00 (0.0)	24.80 (0.9)	54.40 (1.9)	89.50 (3.2)	- (-)	130.30 (4.6)	178.30 (6.3)	240.40 (8.5)	- (-)	334.50 (11.8)	516.70 (18.2)	1028.00 (36.3)

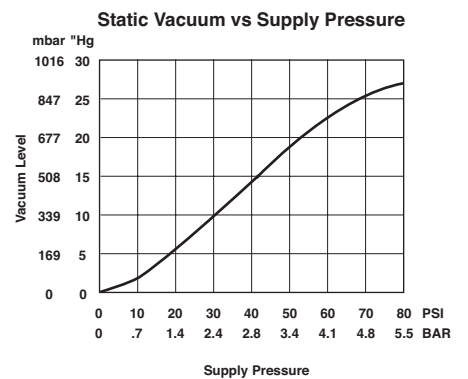
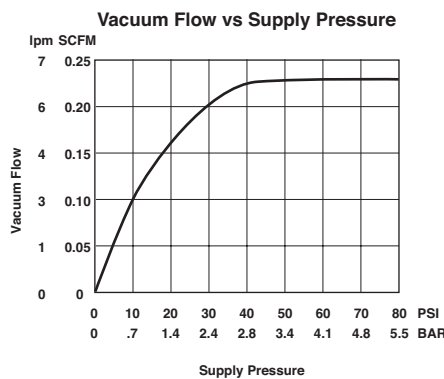
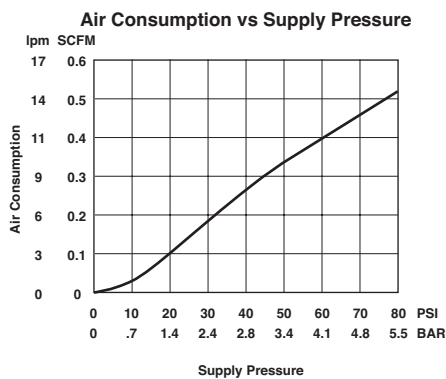

Warnings

Improper selection, misuse, age or malfunction of components used in systems can cause failure in various modes. The system designer is warned to consider the failure modes of all component parts and to provide adequate safeguards to prevent personal injury or damage to equipment or property in the event of such failure modes. System designers and end users are cautioned to consult instruction sheets and specifications available from the factory. The system designer/end user is responsible for verifying that all requirements for the application are met.

Warranty

The products described herein are warranted subject to seller's Standard Terms and Condition of Sale, available at seller's website.

- » Durable – rugged aluminum body construction
- » Strong hold – powerful vacuum up to 28"Hg [948mbar]
- » Fast response – mounts in-line, close to vacuum point - no delay due to long plumbing lines
- » Efficient – minimal air consumption, provides instantaneous vacuum as needed
- » Safe operation – no electricity needed
- » Reliable operation – straight-through design with no moving parts

Technical Data

Fluid
Filtered (50 Micron) unlubricated, non-corrosive dry gasses

Operating Pressure
80 PSI (5.5 bar) Standard or 60 PSI (4.1 bar)

Operating Temperature
-100° to ~400°F (-73° to ~204°C), without silencer

Materials
Generator Body: Anodized Aluminum
Silencer Body : Varies by Size

Supply Line / Vacuum Line
1/4" OD (10mm) for sizes 60M and 90M
3/8" OD (6mm) for sizes 100M and 150M

Performance Level Designations
"NJF" 0-10"Hg [0 to 339mbar] for low vacuum/high flow applications
"NJD" 0-20"Hg [0 to 677mbar] for medium vacuum/high flow applications
"NJS" 0-28"Hg [0 to 948mbar] for high vacuum/standard flow applications



Standard Models

Part Number	Max. Vacuum Level	Max. Vacuum Flow	Air Consumption	Accessories	Material
NJF-90M-S05M01	10"Hg	1.30 SCFM	0.50 SCFM	NST4 Silencer	Aluminum
NJF-100M-S05M01	10"Hg	2.10 SCFM	1.40 SCFM	NST4 Silencer	Aluminum
NJF-150M-S05M01	10"Hg	3.50 SCFM	1.80 SCFM	NST4 Silencer	Aluminum
NJS-90M-S05M01	28"Hg	1.20 SCFM	1.80 SCFM	NST4 Silencer	Aluminum
NJS-100M-S05M01	28"Hg	2.00 SCFM	2.80 SCFM	NST4 Silencer	Aluminum
NJS-150M-S05M01	28"Hg	3.20 SCFM	4.80 SCFM	NST4 Silencer	Aluminum

Option selector

Series	Substitute	NJ - -S M	Materials	Substitute
NJF Imperial Thread 10"Hg [339mbar]	NJF		Aluminum (Standard)	M01
NJD Imperial Thread 20"Hg [677mbar]	NJD		303 Stainless Steel	M05
NJS Imperial Thread 28"Hg [948mbar]	NJS		304 Stainless Steel	M06
NJFM Metric Thread 10"Hg [339mbar]	NJFM		316 Stainless Steel	M07
NJDM Metric Thread 20"Hg [677mbar]	NJDM		316L Stainless Steel	M08
NJSM Metric Thread 28"Hg [948mbar]	NJSM		PVC	M09
Vacuum Flow Level	Substitute		Delrin (Black)	M10
Venturi Cartridge 60M @ 80 PSI (Standard)	60M		Delrin (White)	M11
Venturi Cartridge 90M @ 80 PSI (Standard)	90M		Teflon	M12
Venturi Cartridge 100M @ 80 PSI (Standard)	100M		PEEK	M14
Venturi Cartridge 150M @ 80 PSI (Standard)	150M		Silencers	Substitute
Venturi Cartridge 60M @ 60 PSI	6XM		None (Standard)	S00
Venturi Cartridge 90M @ 60 PSI	9XM	NAA4 (62dB)	S02	
Venturi Cartridge 100M @ 60 PSI	10XM	NST4 (68dB)	S05	
Venturi Cartridge 150M @ 60 PSI	15XM	NSTAA4 (58dB)	S12	



Accessories

Standard Models	Inline Fitting	Swivel Elbow Fitting	Vacuum Fitting	Bellows Cup	Spring Leveler
NJF-90M-S05M01	124250418	124470418	NVCF13-18M	NBG*****	NVSL2-***
NJF-100M-S05M01	124250618	124470618	NVCF13-18M	NBG*****	NVSL2-***
NJF-150M-S05M01	124250618	124470618	NVCF13-18M	NBG*****	NVSL2-***
NJS-90M-S05M01	124250418	124470418	NVCF13-18M	NBG*****	NVSL2-***
NJS-100M-S05M01	124250618	124470618	NVCF13-18M	NBG*****	NVSL2-***
NJS-150M-S05M01	124250618	124470618	NVCF13-18M	NBG*****	NVSL2-***

Dimensions inches (mm)

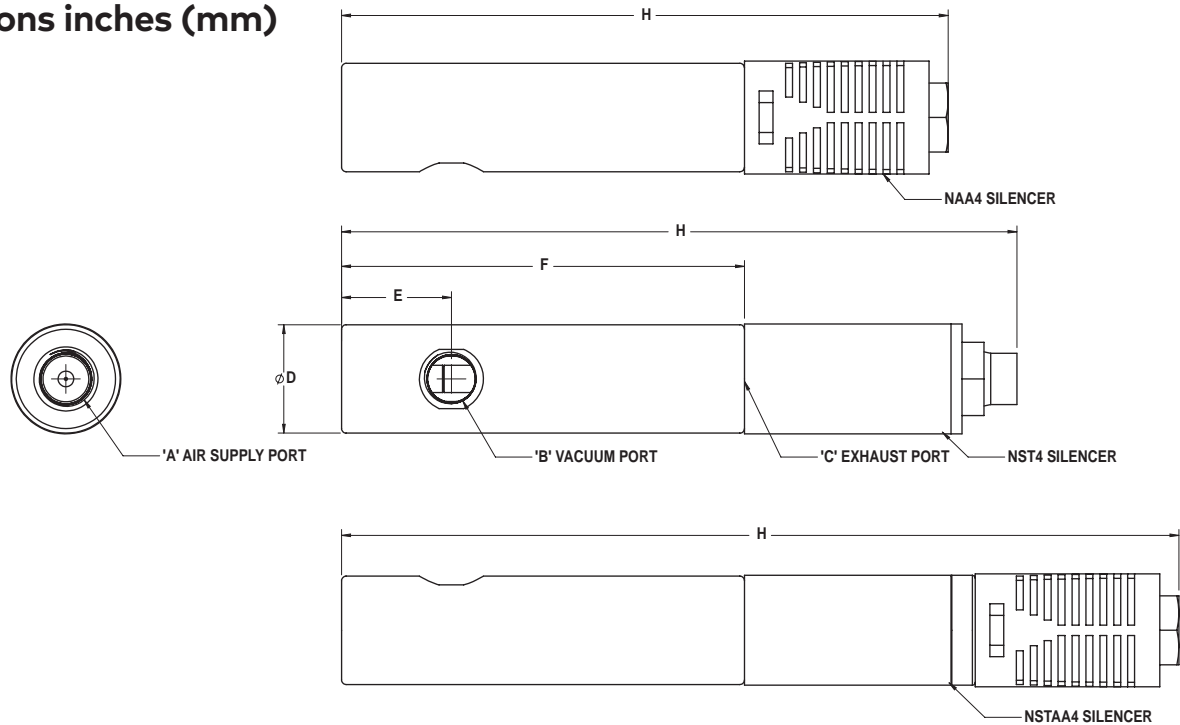

Model	Units	A	B	C	D	E	F	H
NJ*-****-S00M01	Imperial	1/8 NPTF	1/8 NPTF	1/4 NPTF	0.75	0.75	2.75	-
NJ*-****-S02M01	Imperial	1/8 NPTF	1/8 NPTF	1/4 NPTF	0.75	0.75	2.75	4.20
NJ*-****-S05M01	Imperial	1/8 NPTF	1/8 NPTF	1/4 NPTF	0.75	0.75	2.75	4.61
NJ*-****-S12M01	Imperial	1/8 NPTF	1/8 NPTF	1/4 NPTF	0.75	0.75	2.75	5.72
NJ*M-****-S00M01	(Metric)	(G 1/8)	(G 1/8)	(G 1/4)	(19.1)	(19.1)	(69.6)	-
NJ*M-****-S02M01	(Metric)	(G 1/8)	(G 1/8)	(G 1/4)	(19.1)	(19.1)	(69.6)	(105.2)
NJ*M-****-S05M01	(Metric)	(G 1/8)	(G 1/8)	(G 1/4)	(19.1)	(19.1)	(69.6)	(117.1)
NJ*M-****-S12M01	(Metric)	(G 1/8)	(G 1/8)	(G 1/4)	(19.1)	(19.1)	(69.6)	(145.3)

Performance Data

Model	Air Consumption	Vacuum Level	0"Hg	3"Hg	6"Hg	9"Hg	10"Hg
	SCFM (L/min)	"Hg (mbar)	(0)	(102)	(203)	(305)	(339)
NJF-90	0.50 (14.2)	Vacuum Flow SCFM (L/min)	1.30 (36.8)	1.10 (31.1)	0.70 (19.8)	0.20 (5.7)	0.00 (0.0)
		Evacuation time (seconds)	0 (0)	3.26 (0.1)	7.93 (0.3)	18.65 (0.7)	39.63 (1.4)
NJF-100M NJF-100	1.40 (39.6)	Vacuum Flow SCFM (L/min)	2.10 (59.5)	1.60 (45.3)	1.10 (31.1)	0.50 (14.2)	0.00 (0.0)
		Evacuation time (seconds)	0 (0)	2.33 (0.1)	4.66 (0.2)	10.88 (0.4)	24.09 (0.9)
NJF-150M NJF-150	1.80 (51.0)	Vacuum Flow SCFM (L/min)	3.50 (99.1)	2.50 (70.8)	1.90 (53.8)	0.70 (19.8)	0.00 (0.0)
		Evacuation time (seconds)	0.00 (0.0)	2.05 (0.1)	4.62 (0.2)	11.80 (0.4)	22.80 (0.8)

**Air Consumption vs Supply Pressure
Mid Series - "NJF" Models**

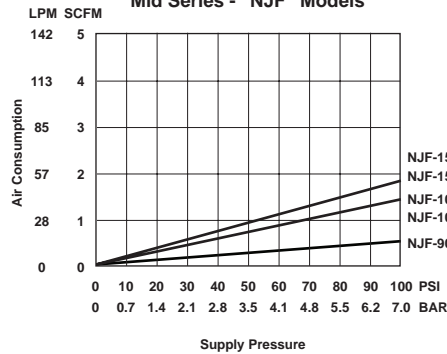

**Vacuum Flow vs Supply Pressure
Mid Series - "NJF" Models**

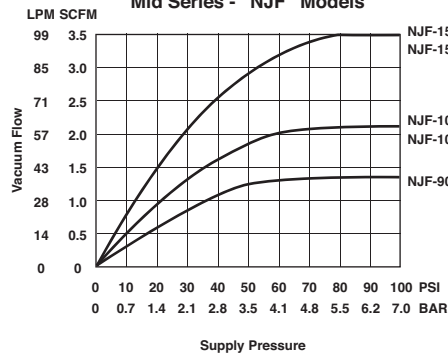

**Static Vacuum vs Supply Pressure
Mid Series - "NJF" Models**

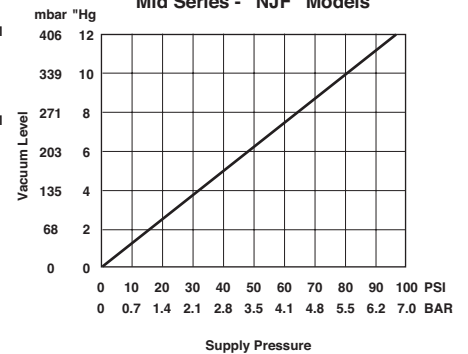

Model	Air Consumption	Vacuum Level	0"Hg	3"Hg	6"Hg	9"Hg	12"Hg	15"Hg	18"Hg	20"Hg
	SCFM (L/min)	"Hg (mbar)	(0)	(102)	(203)	(305)	(406)	(508)	(609)	(677)
NJD-60M	0.50 (14.2)	Vacuum Flow SCFM (L/min)	0.50 (14.2)	0.40 (11.3)	0.30 (8.5)	0.22 (6.2)	0.15 (4.2)	0.08 (2.3)	0.03 (0.8)	0.00 (0.0)
		Evacuation time (seconds)	0.00 (0.0)	12.50 (0.4)	25.10 (0.9)	43.90 (1.6)	68.60 (2.4)	99.30 (3.5)	153.70 (5.4)	227.00 (8.0)
NJD-90M	1.40 (39.6)	Vacuum Flow SCFM (L/min)	1.40 (39.6)	1.25 (35.4)	1.20 (34.0)	1.05 (29.7)	0.85 (24.1)	0.65 (18.4)	0.25 (7.1)	0.00 (0.0)
		Evacuation time (seconds)	0.00 (0.0)	3.75 (0.1)	7.20 (0.3)	12.40 (0.4)	19.10 (0.7)	29.90 (1.1)	52.00 (1.8)	104.00 (3.7)
NJD-100M NJD-100	1.80 (51.0)	Vacuum Flow SCFM (L/min)	2.10 (59.5)	2.00 (56.6)	1.85 (52.4)	1.75 (49.6)	1.60 (45.3)	1.25 (35.4)	0.80 (22.7)	0.00 (0.0)
		Evacuation time (seconds)	0.00 (0.0)	2.65 (0.1)	5.80 (0.2)	9.90 (0.3)	16.20 (0.6)	22.90 (0.8)	36.20 (1.3)	56.60 (2.0)
NJD-150M NJD-150	2.80 (79.3)	Vacuum Flow SCFM (L/min)	3.50 (99.1)	3.20 (90.6)	2.95 (83.5)	2.75 (77.9)	2.50 (70.8)	1.80 (51.0)	0.95 (26.9)	0.00 (0.0)
		Evacuation time (seconds)	0.00 (0.0)	1.35 (0.0)	3.20 (0.1)	5.20 (0.2)	7.70 (0.3)	11.80 (0.4)	23.40 (0.8)	52.00 (1.8)

**Air Consumption vs Supply Pressure
Mid Series - "NJD" Models**

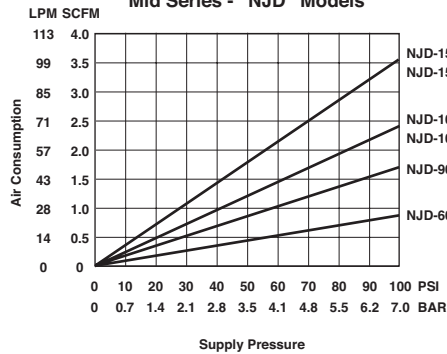

**Vacuum Flow vs Supply Pressure
Mid Series - "NJD" Models**

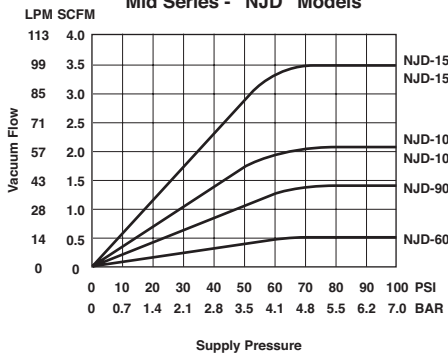

**Static Vacuum vs Supply Pressure
Mid Series - "NJD" Models**

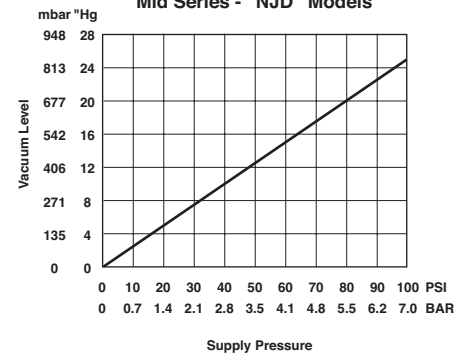



Performance Data

Model	Air Consumption SCFM (L/min)	Vacuum Level "Hg (mbar)	0"Hg (0)	3"Hg (102)	6"Hg (203)	9"Hg (305)	10"Hg (339)	12"Hg (406)	15"Hg (508)	18"Hg (609)	20"Hg (677)	21"Hg (711)	24"Hg (813)	27"Hg (914)	28"Hg (948)
NJS-60M	0.80 (22.7)	Vacuum Flow SCFM (L/min)	0.50 (14.2)	0.38 (10.8)	0.32 (9.1)	0.30 (8.5)	- (-)	0.27 (7.6)	0.23 (6.5)	0.20 (5.7)	- (-)	0.13 (3.7)	0.05 (1.4)	0.02 (0.6)	0.00 (0.0)
		Evacuation time (seconds)	0.00 (0.0)	15.00 (0.5)	29.80 (1.1)	50.60 (1.8)	- (-)	74.50 (2.6)	102.80 (3.6)	135.90 (4.8)	- (-)	183.20 (6.5)	245.90 (8.7)	410.20 (14.5)	790.80 (27.9)
NJS-900M	1.80 (51.0)	Vacuum Flow SCFM (L/min)	1.20 (34.0)	1 (28.3)	0.95 (26.9)	0.90 (25.5)	- (-)	0.85 (24.1)	0.75 (21.2)	0.70 (19.8)	- (-)	0.52 (14.7)	0.47 (13.3)	0.20 (5.7)	0.00 (0.0)
		Evacuation time (seconds)	0.00 (0.0)	6.50 (0.2)	12.30 (0.4)	18.90 (0.7)	- (-)	32.50 (1.1)	47.00 (1.7)	65.40 (2.3)	- (-)	92.20 (3.3)	130.00 (4.6)	222.20 (7.8)	281.30 (9.9)
NJS-100M NJS-100	2.80 (79.3)	Vacuum Flow SCFM (L/min)	2.00 (56.6)	1.85 (52.4)	1.75 (49.6)	1.57 (44.5)	- (-)	1.40 (39.6)	1.25 (35.4)	1.05 (29.7)	- (-)	0.84 (23.8)	0.70 (19.8)	0.35 (9.9)	0.00 (0.0)
		Evacuation time (seconds)	0.00 (0.0)	2.70 (0.1)	6.50 (0.2)	11.20 (0.4)	- (-)	17.50 (0.6)	25.80 (0.9)	38.40 (1.4)	- (-)	55.20 (1.9)	79.20 (2.8)	166.70 (5.9)	251.80 (9.9)
NJS-150M NJS-150	4.80 (135.9)	Vacuum Flow SCFM (L/min)	3.20 (90.6)	2.80 (79.3)	2.50 (70.8)	2.30 (65.1)	- (-)	2 (56.6)	1.60 (45.3)	1.40 (39.6)	- (-)	1.20 (34.0)	0.80 (22.7)	0.50 (14.2)	0.00 (0.0)
		Evacuation time (seconds)	0.00 (0.0)	2.30 (0.1)	3.80 (0.1)	6.50 (0.2)	- (-)	10.20 (0.4)	14.20 (0.5)	21.30 (0.8)	- (-)	44.9 (1.6)	55 (1.9)	81 (2.9)	125 (4.4)

Evacuation time in seconds based on 1 cubic foot volume / "Hg (1 Liter Volume / mbar)

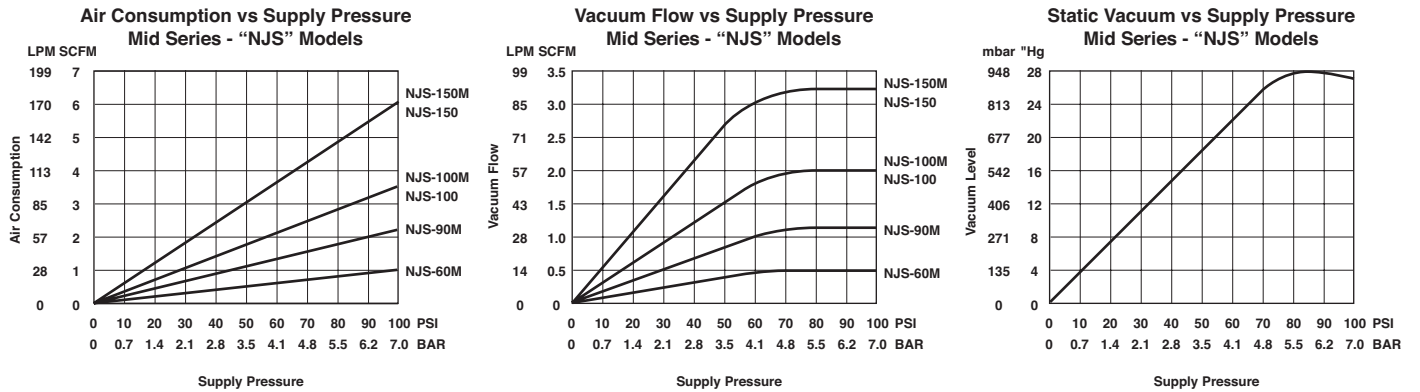

Warnings

Improper selection, misuse, age or malfunction of components used in systems can cause failure in various modes. The system designer is warned to consider the failure modes of all component parts and to provide adequate safeguards to prevent personal injury or damage to equipment or property in the event of such failure modes. System designers and end users are cautioned to consult instruction sheets and specifications available from the factory. The system designer/end user is responsible for verifying that all requirements for the application are met.

Warranty

The products described herein are warranted subject to seller's Standard Terms and Condition of Sale, available at seller's website.

- » Durable – rugged aluminum body construction
- » Strong hold – powerful vacuum up to 28"Hg [948mbar]
- » Fast response – mounts in-line, close to vacuum point - no delay due to long plumbing lines
- » Efficient – minimal air consumption, provides instantaneous vacuum as needed
- » Safe operation – no electricity needed
- » Reliable operation – straight-through design with no moving parts

Technical Data

Fluid
Filtered (50 Micron) unlubricated, non-corrosive dry gasses

Operating Pressure
80 PSI (5.5 bar) Standard or 60 PSI (4.1 bar)

Operating Temperature
-100° to ~400°F (-73° to ~204°C) without silencer

Materials
Generator Body: Anodized Aluminum
Silencer Body : Varies by Size

Supply Line / Vacuum Line
3/8" OD (10mm) for sizes 100-200
1/2" OD (12mm) for size 250

Performance Level Designations
"NJF" 0-10"Hg [0 to 339mbar] for low vacuum/high flow applications
"NJD" 0-20"Hg [0 to 677mbar] for medium vacuum/high flow applications
"NJS" 0-28"Hg [0 to 948mbar] for high vacuum/standard flow applications



Standard Models

Part Number	Max. Vacuum Level	Max. Vacuum Flow	Air Consumption	Accessories	Material
NJF-200-S08M01	10"Hg	6.00 SCFM	2.80 SCFM	NST6A Silencer	Aluminum
NJF-250-S09M01	10"Hg	9.50 SCFM	4.80 SCFM	NST6B Silencer	Aluminum
NJS-200-S08M01	28"Hg	5.40 SCFM	7.80 SCFM	NST6A Silencer	Aluminum
NJS-250-S09M01	28"Hg	9.00 SCFM	12.50 SCFM	NST6B Silencer	Aluminum

Option selector

Series	Substitute	NJ - -S M	Materials	Substitute
NJF Imperial Thread 10"Hg [339mbar]	NJF	<div style="display: flex; justify-content: space-between;"> <div style="width: 30%;"> <p>Vacuum Flow Level</p> <p>Venturi Cartridge 100 @ 80 PSI (Standard) 100</p> <p>Venturi Cartridge 150 @ 80 PSI (Standard) 150</p> <p>Venturi Cartridge 200 @ 80 PSI (Standard) 200</p> <p>Venturi Cartridge 250 @ 80 PSI (Standard) 250</p> <p>Venturi Cartridge 100 @ 60 PSI 10X</p> <p>Venturi Cartridge 150 @ 60 PSI 15X</p> <p>Venturi Cartridge 200 @ 60 PSI 20X</p> <p>Venturi Cartridge 250 @ 60 PSI 25X</p> </div> <div style="width: 30%;"> <p>Silencers</p> <p>None S00</p> <p>NAA6 (70dB) S03</p> <p>NST6A (72dB) S08</p> <p>NST6B (72dB) S09</p> <p>NSTAA6 (64dB) S13</p> <p>NFA-51-375 (72dB) S26</p> </div> </div>	Materials	
NJD Imperial Thread 20"Hg [677mbar]	NJD		Aluminum (Standard) M01	
NJS Imperial Thread 28"Hg [948mbar]	NJS		303 Stainless Steel M05	
NJFM Metric Thread 10"Hg [339mbar]	NJFM		304 Stainless Steel M06	
NJDM Metric Thread 20"Hg [677mbar]	NJDM		316 Stainless Steel M07	
NJSM Metric Thread 28"Hg [948mbar]	NJSM		316L Stainless Steel M08	
		PVC M09		
		Delrin (Black) M10		
		Delrin (White) M11		
		Teflon M12		
		PEEK M14		



Accessories

Standard Models	Inline Fitting	Swivel Elbow Fitting	Vacuum Fitting	Bellows Cup
NJF-200-S08M01	124250628	124470628	NVCF5-38M	NSM045****
NJF-250-S09M01	124250728	124470728	NVCF5-38M	NSM045****
NJS-200-S08M01	124250628	124470628	NVCF5-38M	NSM045****
NJS-250-S09M01	124250728	124470728	NVCF5-38M	NSM045****

*Proper selection of vacuum cups depends on the application. Cups are available in various durometers, colors and materials. If you do not see what you are looking for, please consult factory
 *The fittings, cups, and spring levelers listed are a small selection of possible options please refer to the specific catalog section

Dimensions inches (mm)

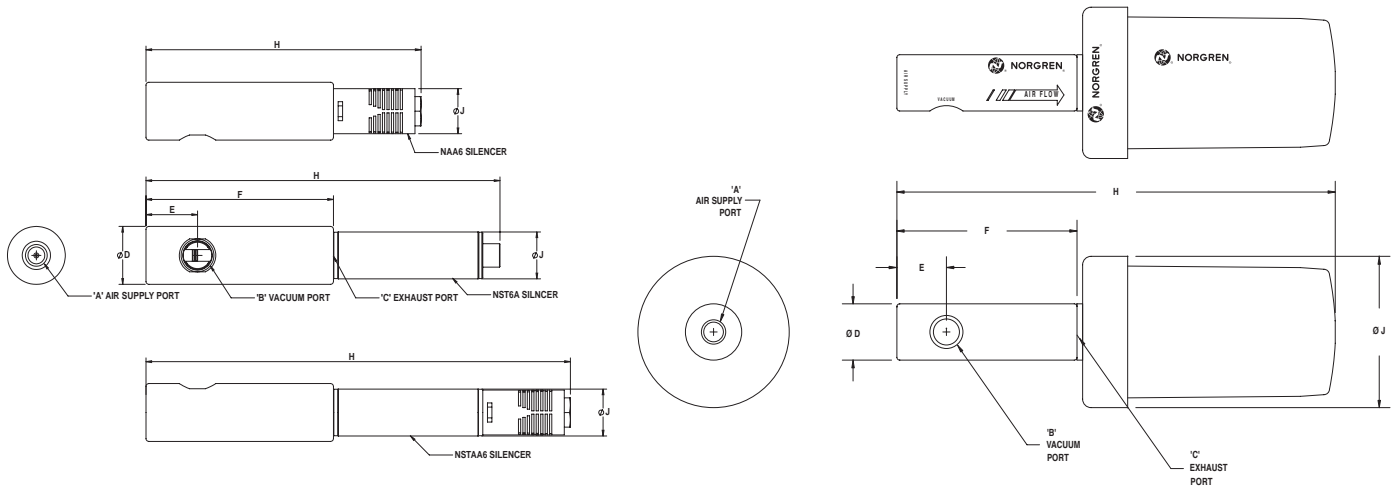

Model	Units	A	B	C	D	E	F	H	J
NJ*-****-S00M01	Imperial	1/4 NPTF	3/8 NPTF	3/8 NPTF	1.25	1.10	4.00	-	-
NJ*-****-S03M01	Imperial	1/4 NPTF	3/8 NPTF	3/8 NPTF	1.25	1.10	4.00	5.87	0.96
NJ*-****-S08M01	Imperial	1/4 NPTF	3/8 NPTF	3/8 NPTF	1.25	1.10	4.00	7.55	1.00
NJ*-****-S13M01	Imperial	1/4 NPTF	3/8 NPTF	3/8 NPTF	1.25	1.10	4.00	9.06	1.00
NJ*-****-S26M01	Imperial	1/4 NPTF	3/8 NPTF	3/8 NPTF	1.25	1.10	4.00	9.74	3.36
NJ*M-****-S00M01	(Metric)	(G 1/4)	(G 3/8)	(G 3/8)	(31.8)	(27.9)	(101.6)	-	-
NJ*M-****-S03M01	(Metric)	(G 1/4)	(G 3/8)	(G 3/8)	(31.8)	(27.9)	(101.6)	(149.1)	(24.4)
NJ*M-****-S08M01	(Metric)	(G 1/4)	(G 3/8)	(G 3/8)	(31.8)	(27.9)	(101.6)	(191.8)	(25.4)
NJ*M-****-S13M01	(Metric)	(G 1/4)	(G 3/8)	(G 3/8)	(31.8)	(27.9)	(101.6)	(230.0)	(25.4)
NJ*M-****-S26M01	(Metric)	(G 1/4)	(G 3/8)	(G 3/8)	(31.8)	(27.9)	(101.6)	(247.3)	(85.3)

Performance Data

Model	Air Consumption SCFM (L/min)	Vacuum Level "Hg (mbar)	0"Hg (0)	3"Hg (102)	6"Hg (203)	9"Hg (305)	10"Hg (339)
NJF-200	2.80 (79.3)	Vacuum Flow SCFM (L/min)	6.00 (169.9)	5.80 (164.2)	4.30 (121.8)	1.70 (48.1)	0.00 (0.0)
		Evacuation time (seconds)	0.00 (0.0)	0.77 (0.0)	2.05 (0.1)	4.62 (0.2)	13.34 (0.5)
NJF-250	4.80 (135.9)	Vacuum Flow SCFM (L/min)	9.50 (269.0)	7.90 (223.7)	5.70 (161.4)	2.20 (62.3)	0.00 (0.0)
		Evacuation time (seconds)	0.00 (0.0)	0.52 (0.0)	1.28 (0.0)	3.08 (0.1)	7.95 (0.3)
NJF-300	7.8 (220.9)	Vacuum Flow SCFM (L/min)	20.00 (566.3)	14.00 (369.4)	9.50 (269.0)	3.50 (99.1)	0.00 (0.0)
		Evacuation time (seconds)	0.00 (0.0)	0.26 (0.0)	0.77 (0.0)	1.80 (0.1)	4.10 (0.1)
NJF-350	12.50 (354.0)	Vacuum Flow SCFM (L/min)	28.00 (792.90)	18.00 (509.70)	12.30 (348.30)	4.50 (127.40)	0.00 (0.0)
		Evacuation time (seconds)	0.00 (0.0)	0.00 (0.0)	0.52 (0.0)	1.28 (0.0)	2.82 (0.1)

Evacuation time in seconds based on 1 cubic foot volume / "Hg (1 Liter Volume / mbar)

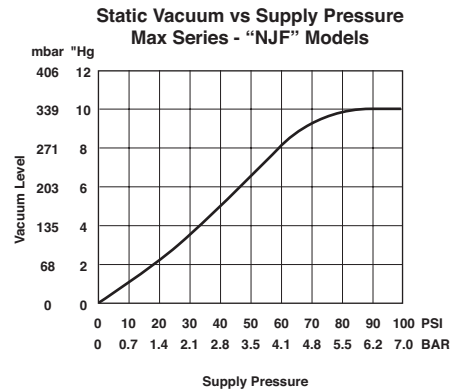
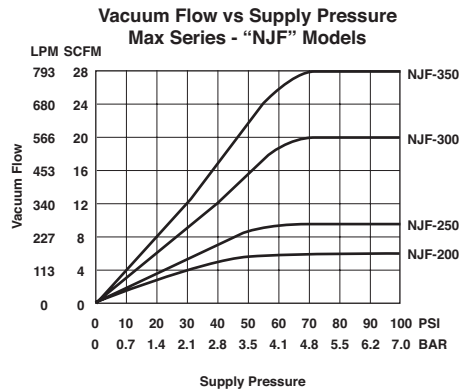
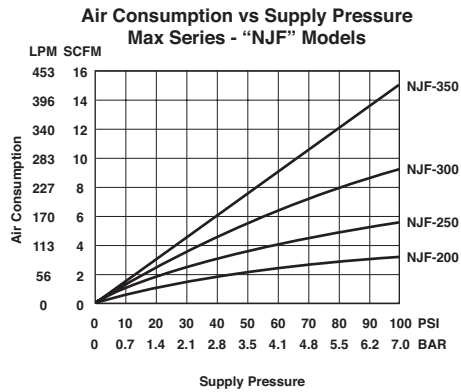



Performance Data

Model	Air Consumption SCFM (L/min)	Vacuum Level "Hg (mbar)	0"Hg (0)	3"Hg (102)	6"Hg (203)	9"Hg (305)	12"Hg (406)	15"Hg (508)	18"Hg (609)	20"Hg (677)
NJD-200	4.80 (135.9)	Vacuum Flow SCFM (L/min)	6.00 (169.9)	5.30 (150.1)	4.90 (138.8)	4.00 (113.3)	3.50 (99.1)	2.50 (70.8)	1.10 (31.1)	0.00 (0.0)
		Evacuation time (seconds)	0.00 (0.0)	0.75 (0.0)	1.90 (0.1)	3.20 (0.1)	5.30 (0.2)	8.70 (0.3)	17.10 (0.6)	42.60 (1.5)
NJD-250	7.80 (220.9)	Vacuum Flow SCFM (L/min)	9.50 (269.0)	9.20 (260.5)	8.30 (235.0)	7.00 (198.2)	4.70 (133.1)	3.40 (96.3)	2.20 (62.3)	0.00 (0.0)
		Evacuation time (seconds)	0.00 (0.0)	0.45 (0.0)	1.10 (0.0)	2.40 (0.1)	3.80 (0.1)	6.00 (0.2)	9.70 (0.3)	15.40 (0.5)
NJD-300	12.50 (354.0)	Vacuum Flow SCFM (L/min)	20.00 (566.3)	19.00 (538.0)	16.30 (461.6)	13.80 (390.8)	8.10 (229.4)	5.50 (155.7)	3.30 (93.4)	0.00 (0.0)
		Evacuation time (seconds)	0.00 (0.0)	0.00 (0.0)	0.00 (0.0)	1.10 (0.0)	1.80 (0.1)	2.70 (0.1)	4.60 (0.2)	8.70 (0.3)
NJD-350	22.00 (623.0)	Vacuum Flow SCFM (L/min)	28.00 (792.9)	24.00 (679.6)	19.40 (549.3)	16.80 (475.7)	14.50 (410.6)	11.20 (317.1)	4.80 (135.9)	0.00 (0.0)
		Evacuation time (seconds)	0.00 (0.0)	0.00 (0.0)	0.00 (0.0)	1.00 (0.0)	1.50 (0.1)	2.10 (0.1)	4.30 (0.2)	8.40 (0.3)

Evacuation time in seconds based on 1 cubic foot volume / "Hg (1 Liter Volume / mbar)

Air Consumption vs Supply Pressure
Max Series - "NJD" Models

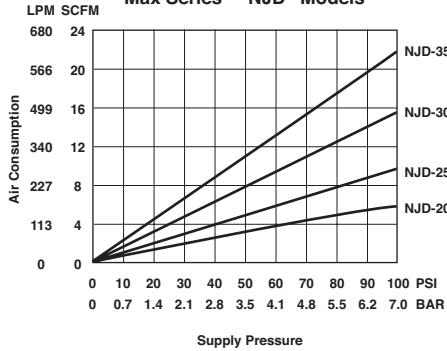

Vacuum Flow vs Supply Pressure
Max Series - "NJD" Models

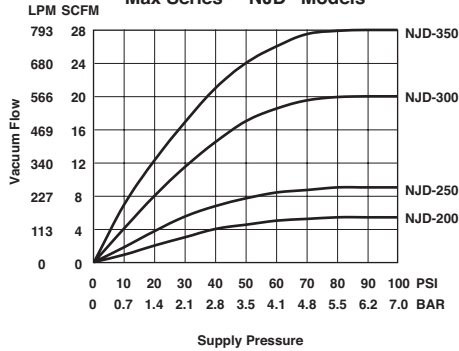

Static Vacuum vs Supply Pressure
Max Series - "NJD" Models

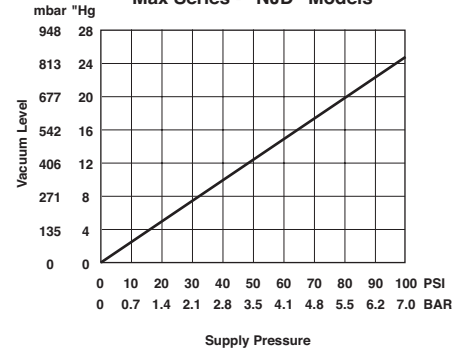

Performance Data

Model	Air Consumption		Vacuum Level												
	SCFM (L/min)	"Hg (mbar)	(0)	(102)	(203)	(305)	(339)	(406)	(508)	(609)	(677)	(711)	(813)	(914)	(948)
NJS-200	7.80 (220.9)	Vacuum Flow SCFM (L/min)	5.40 (152.9)	4.70 (133.1)	3.85 (109.0)	3.30 (93.4)	- (-)	3.00 (85.0)	2.60 (73.6)	2.10 (59.5)	- (-)	1.60 (45.3)	1.20 (34.0)	0.60 (17.0)	0.00 (0.0)
		Evacuation time (seconds)	0.00 (0.0)	1.20 (0.0)	2.10 (0.1)	3.40 (0.1)	- (-)	5.20 (0.2)	7.70 (0.3)	11.50 (0.4)	- (-)	20.00 (0.7)	33.50 (1.2)	62.60 (2.2)	98.10 (3.5)
NJS-250	12.50 (354.0)	Vacuum Flow SCFM (L/min)	9.00 (254.9)	8.50 (240.7)	7.85 (222.3)	7.00 (198.2)	- (-)	6.50 (184.1)	5.30 (150.1)	3.90 (110.4)	- (-)	2.50 (70.8)	1.80 (51.0)	0.90 (25.5)	0.00 (0.0)
		Evacuation time (seconds)	0.00 (0.0)	0.75 (0.0)	1.30 (0.0)	2.20 (0.1)	- (-)	3.50 (0.1)	5.60 (0.2)	9.10 (0.3)	- (-)	17.40 (0.6)	30.10 (1.1)	56.00 (2.0)	76.00 (2.7)
NJS-300	22.00 (623.0)	Vacuum Flow SCFM (L/min)	20.00 (566.3)	17.00 (481.4)	14.00 (396.4)	12.70 (359.6)	- (-)	12.00 (339.8)	10.00 (238.2)	7.40 (209.5)	- (-)	4.90 (138.8)	2.70 (76.5)	1.30 (36.8)	0.00 (0.0)
		Evacuation time (seconds)	0.00 (0.0)	0.00 (0.0)	0.80 (0.0)	1.20 (0.0)	- (-)	2.00 (0.1)	2.80 (0.1)	3.90 (0.1)	- (-)	5.90 (0.2)	11.10 (0.4)	32.70 (1.2)	60.00 (2.1)
NJS-350	28.00 (792.9)	Vacuum Flow SCFM (L/min)	28.00 (792.9)	22.00 (623)	18.70 (529.50)	15.90 (450.20)	- (-)	14.50 (410.60)	11.80 (334.10)	8.10 (229.40)	- (-)	5.70 (161.40)	4.50 (127.40)	2.25 (63.70)	0 (0)
		Evacuation time (seconds)	0.00 (0.0)	0.00 (0.0)	0.00 (0.0)	1.20 (0.0)	- (-)	1.90 (0.1)	2.30 (0.1)	3.40 (0.1)	- (-)	5.30 (0.2)	8.80 (0.3)	26.00 (0.9)	44.00 (1.6)

Evacuation time in seconds based on 1 cubic foot volume / "Hg (1 Liter Volume / mbar)

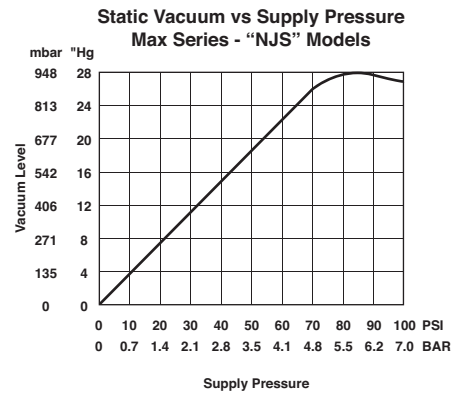
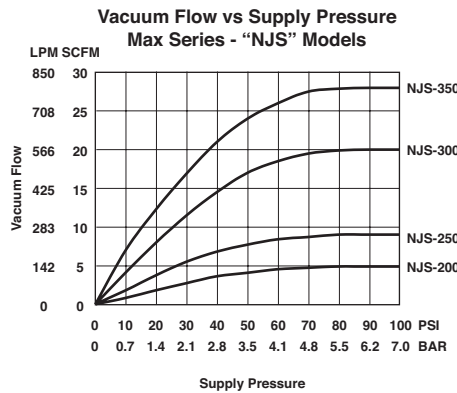
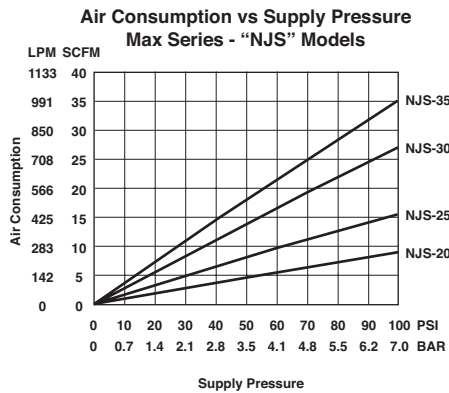

Warnings

Improper selection, misuse, age or malfunction of components used in systems can cause failure in various modes. The system designer is warned to consider the failure modes of all component parts and to provide adequate safeguards to prevent personal injury or damage to equipment or property in the event of such failure modes. System designers and end users are cautioned to consult instruction sheets and specifications available from the factory. The system designer/end user is responsible for verifying that all requirements for the application are met.

Warranty

The products described herein are warranted subject to seller's Standard Terms and Condition of Sale, available at seller's website.



- » Durable – rugged aluminum body construction
- » Strong hold – powerful vacuum up to 28"Hg [948mbar]
- » Fast response – mounts in-line, close to vacuum point - no delay due to long plumbing lines
- » Efficient – minimal air consumption, provides instantaneous vacuum as needed
- » Safe operation – no electricity needed
- » Reliable operation – straight-through design with no moving parts

Technical Data

Fluid
Filtered (50 Micron) unlubricated, non-corrosive dry gasses

Operating Pressure
80 PSI (5.5 bar) Standard or 60 PSI (4.1 bar)

Operating Temperature
-100° to 400°F (-73° to -204°C) without silencer

Materials
Generator Body: Anodized Aluminum
Silencer Body : Varies by Size

Supply Line
1/2" OD (12mm)

Vacuum Line
1/2" OD (12mm) preferred - 3/4" OD (19mm) for lines exceeding 3' (1mm)

Performance Level Designations
"NJF" 0-10"Hg [0 to 339mbar] for low vacuum/high flow applications
"NJD" 0-20"Hg [0 to 677mbar] for medium vacuum/high flow applications
"NJS" 0-28"Hg [0 to 948mbar] for high vacuum/standard flow applications







Standard Models

Part Number	Max. Vacuum Level	Max. Vacuum Flow	Air Consumption	Accessories	Material
NJF-300-S09M01	10"Hg	20.00 SCFM	7.80 SCFM	NST6B Silencer	Aluminum
NJF-350-S11M01	10"Hg	28.00 SCFM	12.50 SCFM	NST8B Silencer	Aluminum
NJS-300-S09M01	28"Hg	20.00 SCFM	22.00 SCFM	NST6B Silencer	Aluminum
NJS-350-S11M01	28"Hg	28.00 SCFM	28.00 SCFM	NST8B Silencer	Aluminum

Option selector

Series	Substitute	Materials	Substitute
NJF Imperial Thread 10"Hg [339mbar]	NJF	Aluminum (Standard)	M01
NJD Imperial Thread 20"Hg [677mbar]	NJD	303 Stainless Steel	M05
NJS Imperial Thread 28"Hg [948mbar]	NJS	304 Stainless Steel	M06
NJFM Metric Thread 10"Hg [339mbar]	NJFM	316 Stainless Steel	M07
NJDM Metric Thread 20"Hg [677mbar]	NJDM	316L Stainless Steel	M08
NJSM Metric Thread 28"Hg [948mbar]	NJSM	PVC	M09
		Delrin (Black)	M10
		Delrin (White)	M11
		Teflon	M12
		PEEK	M14
Vacuum Flow Level	Substitute	Silencers (For NJ*-300)	Substitute
Venturi Cartridge 300 @ 80 PSI (Standard)	300	None (Standard)	S00
Venturi Cartridge 350 @ 80 PSI (Standard)	350	NST6B (72dB)	S09
Venturi Cartridge 300 @ 60 PSI (Standard)	30X	NFA-51-.375 (72dB)	S26
Venturi Cartridge 350 @ 60 PSI (Standard)	35X	Silencers (For NJ*-350)	Substitute
		None (Standard)	S00
		NST8B (76dB)	S11
		NFA-51-.500 (72dB)	S27

Accessories

Standard Models	Inline Fitting	Swivel Elbow Fitting	Vacuum Fitting	Bellows Cup
NJF-300-S09M01				
NJF-350-S11M01	124250738	124470738	NVCF5-38M	NSM045****
NJS-300-S09M01	124250748	124470738	-	-
NJS-350-S11M01	124250738	124470738	NVCF5-38M	NSM045****
NJS-350-S11M01	124250748	124470738	-	-

*Proper selection of vacuum cups depends on the application. Cups are available in various durometers, colors and materials. If you do not see what you are looking for, please consult factory
*The fittings, cups, and spring levelers listed are a small selection of possible options please refer to the specific catalog section

Dimensions inches (mm)

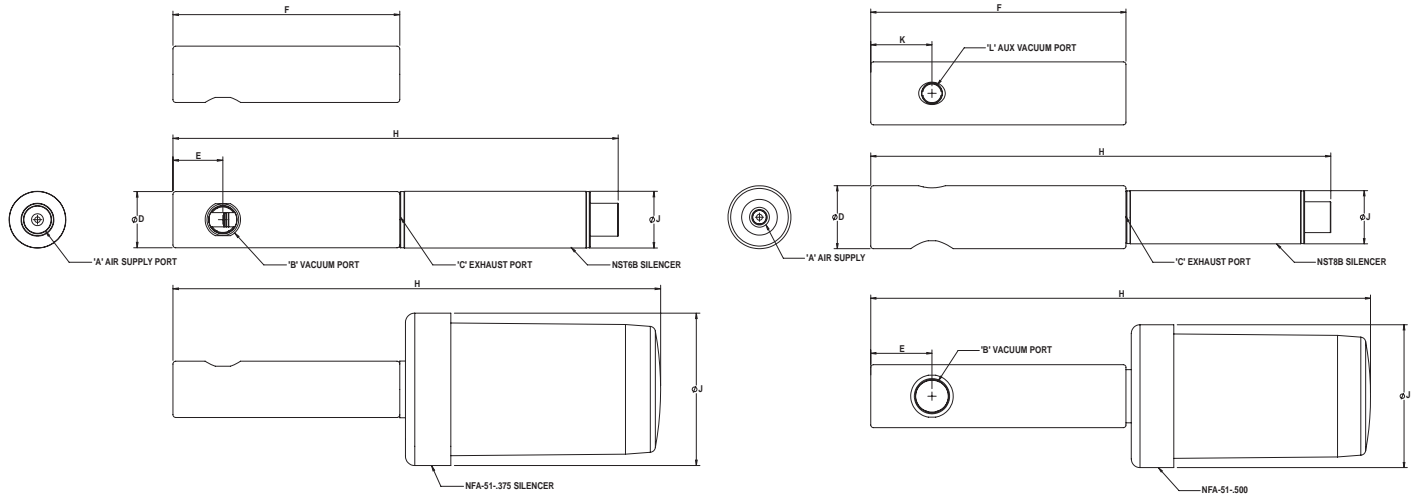

Model	Units	A	B	C	D	E	F	H	J	K	L
NJ*-300-S00M01	Imperial	3/8 NPTF	3/8 NPTF	3/8 NPTF	1.25	1.10	5.00	-	-	N/A	N/A
NJ*-300-S09M01	Imperial	3/8 NPTF	3/8 NPTF	3/8 NPTF	1.25	1.10	5.00	9.81	1.25	N/A	N/A
NJ*-300-S26M01	Imperial	3/8 NPTF	3/8 NPTF	3/8 NPTF	1.25	1.10	5.00	10.74	3.36	N/A	N/A
NJ*-350-S00M01	Imperial	1/2 NPTF	1/2 NPTF	1/2 NPTF	1.50	1.44	6.00	-	-	1.44	1/4 NPTF
NJ*-350-S11M01	Imperial	1/2 NPTF	1/2 NPTF	1/2 NPTF	1.50	1.44	6.00	10.82	1.25	1.44	1/4 NPTF
NJ*-350-S27M01	Imperial	1/2 NPTF	1/2 NPTF	1/2 NPTF	1.50	1.44	6.00	11.75	3.36	1.44	1/4 NPTF
NJ*M-300-S00M01	(Metric)	(G 3/8)	(G 3/8)	(G 3/8)	(31.8)	(27.9)	(127.0)	(-)	(-)	(N/A)	(N/A)
NJ*M-300-S09M01	(Metric)	(G 3/8)	(G 3/8)	(G 3/8)	(31.8)	(27.9)	(127.0)	(249.2)	(31.8)	(N/A)	(N/A)
NJ*M-300-S26M01	(Metric)	(G 3/8)	(G 3/8)	(G 3/8)	(31.8)	(27.9)	(127.0)	(272.7)	(85.3)	(N/A)	(N/A)
NJ*M-350-S00M01	(Metric)	(G 1/2)	(G 1/2)	(G 1/2)	(31.8)	(36.5)	(152.4)	(-)	(-)	(36.5)	(G 1/4)
NJ*M-350-S11M01	(Metric)	(G 1/2)	(G 1/2)	(G 1/2)	(31.8)	(36.5)	(152.4)	(247.7)	(31.8)	(36.5)	(G 1/4)
NJ*M-350-S27M01	(Metric)	(G 1/2)	(G 1/2)	(G 1/2)	(31.8)	(36.5)	(152.4)	(298.5)	(85.3)	(36.5)	(G 1/4)

Performance Data

Model	Air Consumption SCFM (L/min)	Vacuum Level "Hg (mbar)	0"Hg (0)	3"Hg (102)	6"Hg (203)	9"Hg (305)	10"Hg (339)
NJF-300	7.80 (220.9)	Vacuum Flow SCFM (L/min)	20.00 (566.3)	14.00 (369.4)	9.50 (269.0)	3.5 (99.1)	0.00 (0.0)
		Evacuation time (seconds)	0.00 (0.0)	0.26 (0.0)	0.77 (0.0)	1.8 (0.1)	4.10 (0.1)
NJF-350	12.50 (354.0)	Vacuum Flow SCFM (L/min)	28.00 (792.9)	18.00 (509.7)	12.30 (348.3)	4.5 (127.4)	0.00 (0.0)
		Evacuation time (seconds)	0.00 (0.0)	0.00 (0.0)	0.52 (0.0)	1.28 (0.0)	2.82 (0.1)

Evacuation time in seconds based on 1 cubic foot volume / "Hg (1 Liter Volume / mbar)

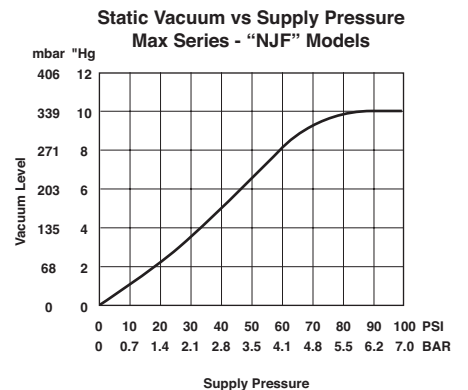
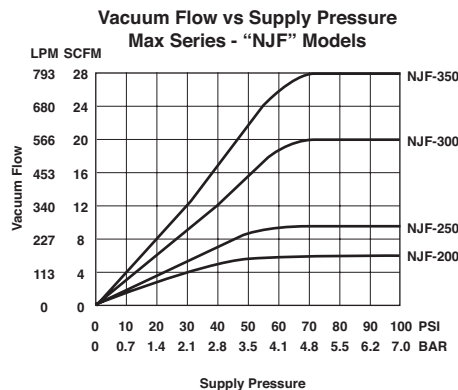
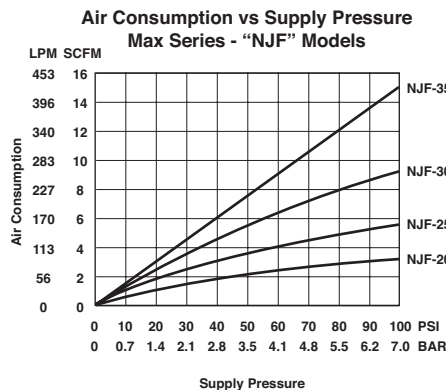



Performance Data

Model	Air Consumption SCFM (L/min)	Vacuum Level "Hg (mbar)	0"Hg (0)	3"Hg (102)	6"Hg (203)	9"Hg (305)	12"Hg (406)	15"Hg (508)	18"Hg (609)	20"Hg (677)
NJD-300	12.50 (354)	Vacuum Flow SCFM (L/min)	20.00 (566.3)	19.00 (538.0)	16.30 (461.6)	13.80 (390.8)	8.10 (229.4)	5.50 (155.7)	3.30 (93.4)	0.00 (0.0)
		Evacuation time (seconds)	0.00 (0.0)	0.00 (0.0)	0.0 (0.00)	1.10 (0.0)	1.80 (0.1)	2.70 (0.1)	4.60 (0.2)	8.70 (0.3)
NJD-350	22.00 (623)	Vacuum Flow SCFM (L/min)	28.00 (792.9)	24.00 (679.6)	19.40 (549.3)	16.80 (475.7)	14.50 (410.6)	11.20 (317.1)	4.80 (135.9)	0.00 (0.0)
		Evacuation time (seconds)	0.00 (0.0)	0.00 (0.0)	0.00 (0.0)	1.00 (0.0)	1.50 (0.1)	2.10 (0.1)	4.30 (0.2)	8.40 (0.0)

Evacuation time in seconds based on 1 cubic foot volume / "Hg (1 Liter Volume / mbar)

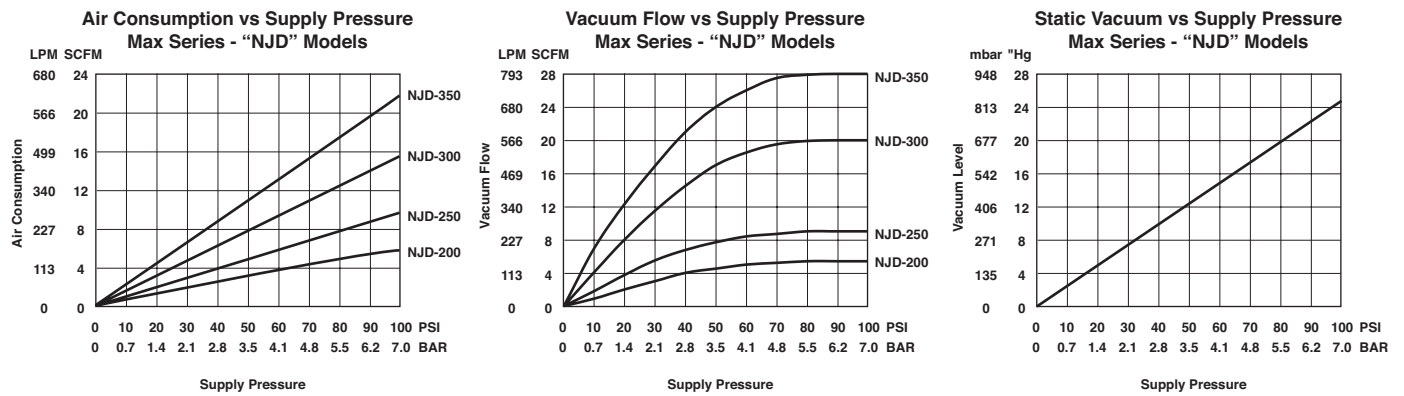

Model	Air Consumption SCFM (L/min)	Vacuum Level "Hg (mbar)	0"Hg (0)	3"Hg (102)	6"Hg (203)	9"Hg (305)	10"Hg (339)	12"Hg (406)	15"Hg (508)	18"Hg (609)	20"Hg (677)	21"Hg (711)	24"Hg (813)	27"Hg (914)	28"Hg (948)
NJS-300	22.00 (623.0)	Vacuum Flow SCFM (L/min)	20.00 (566.3)	17.00 (481.4)	14.00 (396.4)	12.70 (359.6)	- (-)	12.00 (339.8)	10.00 (238.2)	7.40 (209.5)	- (-)	4.90 (138.8)	2.70 (76.5)	1.30 (36.8)	0.00 (0.0)
		Evacuation time (seconds)	0.00 (0.0)	0.00 (0.0)	0.80 (0.0)	1.20 (0.0)	- (-)	2.00 (0.1)	2.80 (0.1)	3.90 (0.1)	- (-)	5.90 (0.2)	11.10 (0.4)	32.70 (1.2)	60.00 (2.1)
NJS-350	28.00 (792.9)	Vacuum Flow SCFM (L/min)	28.00 (792.9)	22.00 (623.0)	18.70 (529.5)	15.90 (450.2)	- (-)	14.50 (410.6)	11.80 (334.1)	8.10 (229.4)	- (-)	5.7 (161.4)	4.5 (127.4)	2.25 (63.7)	0.00 (0.0)
		Evacuation time (seconds)	0.00 (0.0)	0.00 (0.0)	0.00 (0.0)	1.20 (0.0)	- (-)	1.90 (0.1)	2.30 (0.1)	3.40 (0.1)	- (-)	5.30 (0.2)	8.80 (0.3)	26.00 (0.9)	44.00 (1.6)

Evacuation time in seconds based on 1 cubic foot volume / "Hg (1 Liter Volume / mbar)

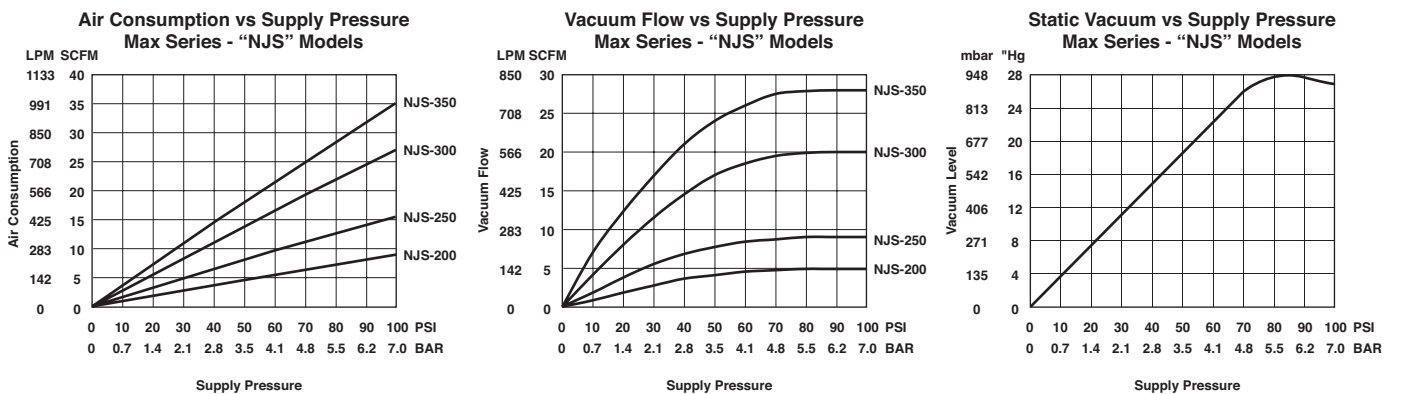

Warnings

Improper selection, misuse, age or malfunction of components used in systems can cause failure in various modes. The system designer is warned to consider the failure modes of all component parts and to provide adequate safeguards to prevent personal injury or damage to equipment or property in the event of such failure modes. System designers and end users are cautioned to consult instruction sheets and specifications available from the factory. The system designer/end user is responsible for verifying that all requirements for the application are met.

Warranty

The products described herein are warranted subject to seller's Standard Terms and Condition of Sale, available at seller's website.

- » High Productivity – non-clogging design reduces downtime
- » Strong hold – powerful vacuum up to 24" Hg [813mbar]
- » Mounts Easily – compact and lightweight
- » Fast Response – installs close to vacuum point
- » Efficient – minimal air consumption
- » Reliable operation – straight-through design with no moving parts

Technical Data

Fluid
 Filtered (50 Micron) unlubricated, non-corrosive dry gases

Operating Temperature
 -30° to ~250°F (-34° to ~121°C)

Operating Pressure
 80 PSI (5.5 bar) Standard or 60 PSI (4.1 bar)

Materials
 Generator Body: Anodized Aluminum

Supply Line
 1/4" OD (6mm) tube

Vacuum Line
 1/4" OD (6mm) tube

Mounting Holes
 5/8"-18 male thread (optional jam nut: JN)

Control Valve
 3 way/2 position (faster part release), minimum orifice – 0.125" [3mm]



Standard Models

Part Number	Max. Vacuum Level	Max. Vacuum Flow	Air Consumption
NVPI-90H-NN-A00	24" Hg	1.20 SCFM	1.80 SCFM
NVPI-90H-JN-A00	24" Hg	1.20 SCFM	1.80 SCFM

Option selector

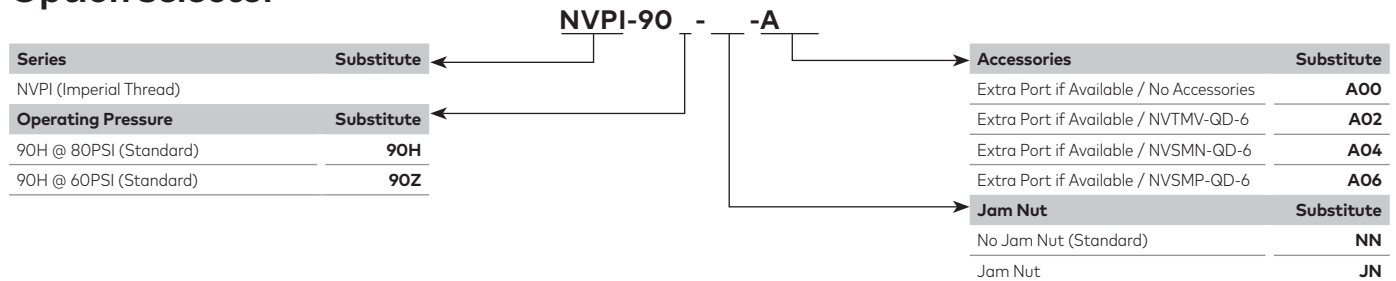



Dimensions inches (mm)

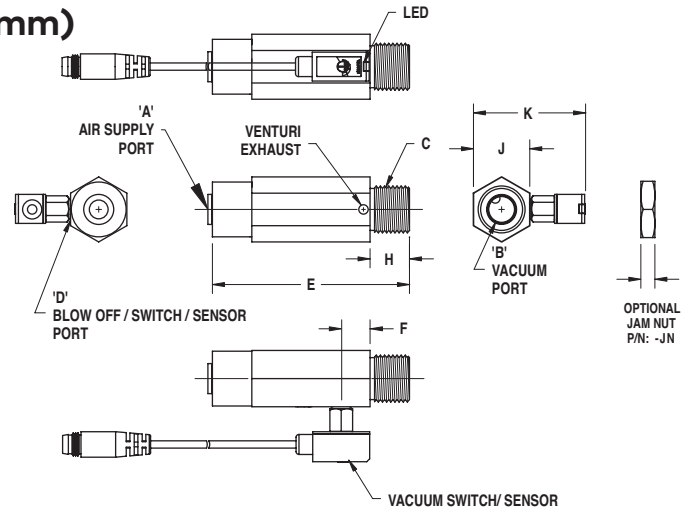

Model	Units	A	B	C	D	E	F	H	J	K	L
NVPI-90H-JN-AOO	Imperial	1/4 PTC	1/8 NPTF	5/8-18 UNF	M5	2.63	0.32	0.53	0.75	0.91	0.19
NVPI-90H-JN-A**	Imperial	1/4 PTC	1/8 NPTF	5/8-18 UNF	M5	2.63	0.32	0.53	0.75	1.50	0.19

Performance Data

Model	Air Consumption SCFM (L/min)	Vacuum Level "Hg (mbar)	0"Hg	3"Hg	6"Hg	9"Hg	12"Hg	15"Hg	18"Hg	21"Hg	24"Hg
			(0)	(102)	(203)	(305)	(406)	(508)	(609)	(711)	(813)
NVPI-90H	1.80 (51.0)	Vacuum Flow SCFM (L/min)	1.20 (34.0)	1.00 (28.3)	0.95 (26.9)	0.90 (25.5)	0.85 (24.1)	0.75 (21.2)	0.70 (19.8)	0.52 (14.7)	0.47 (13.3)
		Evacuation time (seconds)	0.00 (0.0)	6.50 (0.2)	12.30 (0.4)	18.90 (0.7)	32.50 (1.1)	47.00 (1.7)	65.40 (2.3)	92.20 (3.3)	130.00 (4.6)

Evacuation time in seconds based on 1 cubic foot volume / "Hg (1 Liter Volume / mbar)
Evacuation speed is linear with volume. A 2 cu. ft. volume will take twice as long to evacuate as a 1 cu. ft. volume.

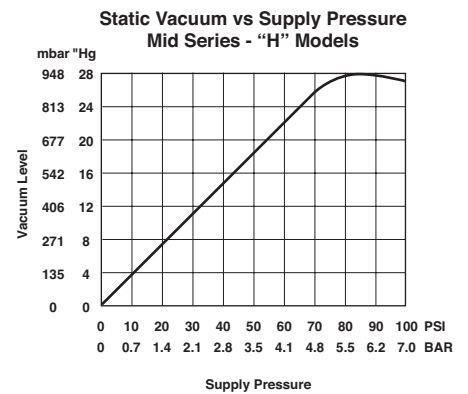
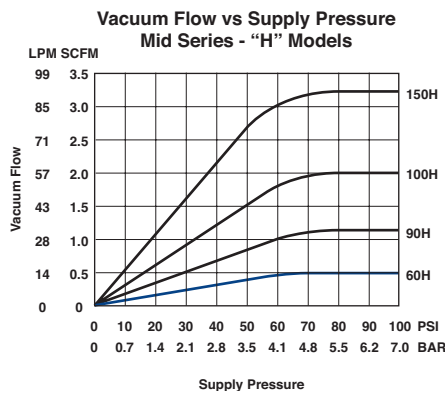
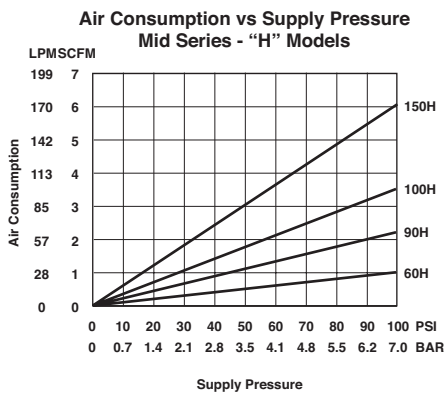

Warnings

Improper selection, misuse, age or malfunction of components used in systems can cause failure in various modes. The system designer is warned to consider the failure modes of all component parts and to provide adequate safeguards to prevent personal injury or damage to equipment or property in the event of such failure modes. System designers and end users are cautioned to consult instruction sheets and specifications available from the factory. The system designer/end user is responsible for verifying that all requirements for the application are met.

Warranty

The products described herein are warranted subject to seller's Standard Terms and Condition of Sale, available at seller's website.

- » Lightweight and compact for easy point-of-use installation
- » Strong hold – powerful vacuum up to 27.1"Hg [918mbar]
- » Inline mounting with push-to-connect fittings for quick installation
- » Fast Response – installs close to vacuum point
- » Efficient – minimal air consumption
- » Reliable operation – straight-through design with no moving parts
- » Built-in silencers for quiet operation

Technical Data

Fluid

Filtered (50 Micron) unlubricated, non-corrosive dry gases

Operating Temperature
32° to ~120° F (0° to ~ 99°C)

Operating Pressure
72 PSI (5.0 bar)

Materials

Generator Body: Nylon
Fitting: Nickel plated brass

Supply Line

6mm OD

Vacuum Line

6mm OD

Exhaust Line

8mm OD (NMPVGM-T Model only)



Standard Models

Part Number	Max. Vacuum Level	Max. Vacuum Flow	Air Consumption
NMPVGM-B-55H	27.1"Hg	0.45 SCFM	0.80 SCFM
NMPVGM-B-95H	27.1"Hg	1.34 SCFM	2.45 SCFM
NMPVGM-T-85H	26.8"Hg	0.99 SCFM	1.60 SCFM
NMPVGM-I-35H	26.8"Hg	0.25 SCFM	0.40 SCFM
NMPVGM-I-85H	26.8"Hg	0.99 SCFM	1.60 SCFM
NMPVGM-I-35H-18M	26.8"Hg	0.25 SCFM	0.40 SCFM
NMPVGM-I-85H-18M	26.8"Hg	0.99 SCFM	1.60 SCFM



Dimensions inches (mm)

NMPVGM-B-55H
NMPVGM-B-95H

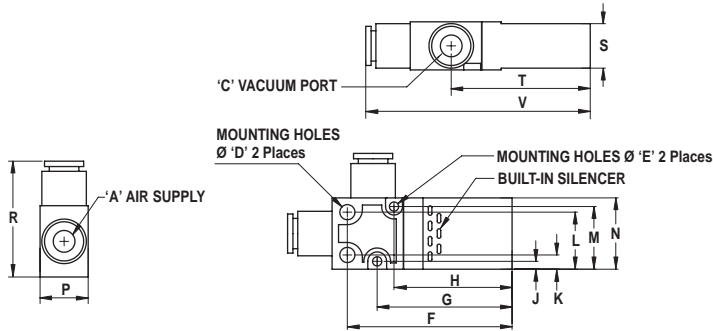

NMPVGM-T-85H

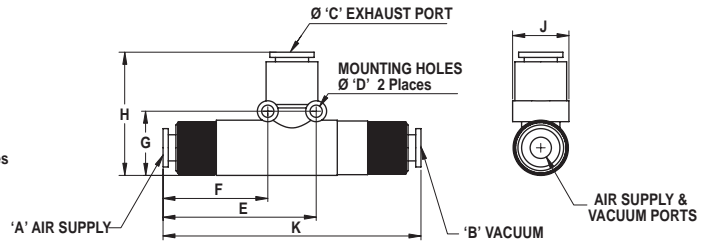

NMPVGM-I-35H
NMPVGM-I-85H

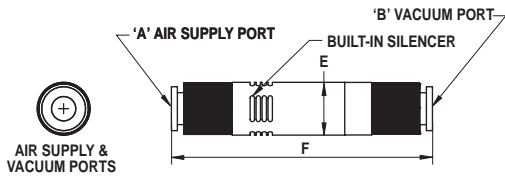

NMPVGM-I-35H-18M
NMPVGM-I-85H-18M

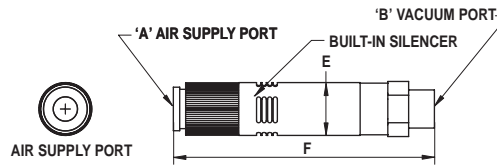

Dimensions inches (mm)

Model	Units	A	B	C	D	E	F	G	H	J	K	L	M	N	P	R	S	T	V
NMPVGM-B-55H	Imperial	6mm PTC	-	6mm PTC	0.17	0.1	1.82	1.49	1.3	0.09	0.16	0.63	0.69	0.79	0.53	1.28	0.49	1.54	2.48
	(Metric)	(6mm PTC)	(-)	(6mm PTC)	(4.0)	(3.0)	(46.0)	(38.0)	(33)	(2.0)	(4.0)	(16.0)	(18.0)	(20.0)	(14.0)	(33.0)	(13.0)	(39.0)	(63.0)
NMPVGM-B-95H	Imperial	6mm PTC	-	6mm PTC	0.17	0.1	1.82	1.49	1.3	0.09	0.16	0.63	0.69	0.79	0.53	1.28	0.49	1.54	2.48
	(Metric)	(6mm PTC)	(-)	(6mm PTC)	(4.0)	(3.0)	(46.0)	(38.0)	(33)	(2.0)	(4.0)	(16.0)	(18.0)	(20.0)	(14.0)	(33.0)	(13.0)	(39.0)	(63.0)
NMPVGM-T-85H	Imperial	6mm PTC	6mm PTC	8mm PTC	0.14	1.73	1.18	0.73	1.39	0.59	2.91	-	-	-	-	-	-	-	-
	(Metric)	(6mm PTC)	(6mm PTC)	(8mm PTC)	(3.5)	(43.9)	(30.1)	(18.4)	(35.4)	(15.0)	(74.0)	(-)	(-)	(-)	(-)	(-)	(-)	(-)	(-)
NMPVGM-I-35H	Imperial	6mm PTC	6mm PTC	-	-	0.52	2.58	-	-	-	-	-	-	-	-	-	-	-	-
	(Metric)	(6mm PTC)	(6mm PTC)	(-)	(-)	(13.0)	(66.0)	(-)	(-)	(-)	(-)	(-)	(-)	(-)	(-)	(-)	(-)	(-)	(-)
NMPVGM-I-85H	Imperial	6mm PTC	6mm PTC	-	-	0.62	2.91	-	-	-	-	-	-	-	-	-	-	-	-
	(Metric)	(6mm PTC)	(6mm PTC)	(-)	(-)	(16.0)	(74.0)	(-)	(-)	(-)	(-)	(-)	(-)	(-)	(-)	(-)	(-)	(-)	(-)
NMPVGM-I-35H-18M	Imperial	6mm PTC	G 1/8	-	-	0.52	2.58	-	-	-	-	-	-	-	-	-	-	-	-
	(Metric)	(6mm PTC)	(G 1/8)	(-)	(-)	(13.0)	(66.0)	(-)	(-)	(-)	(-)	(-)	(-)	(-)	(-)	(-)	(-)	(-)	(-)
NMPVGM-I-85H-18M	Imperial	6mm PTC	G 1/8	-	-	0.62	2.91	-	-	-	-	-	-	-	-	-	-	-	-
	(Metric)	(6mm PTC)	(G 1/8)	(-)	(-)	(16.0)	(74.0)	(-)	(-)	(-)	(-)	(-)	(-)	(-)	(-)	(-)	(-)	(-)	(-)

Model	Air Consumption SCFM (L/min)	Maximum Vacuum "Hg (mbar)	Maximum Vacuum Flow SCFM (L/min)
NMPVGM-B-55H	0.80	27.10	0.45
	(22.6)	(918.0)	(12.7)
NMPVGM-B-95H	2.45	27.10	1.34
	(69.4)	(918.0)	(37.9)
NMPVGM-T-85H	1.60	26.80	0.99
	(45.3)	(908.0)	(28.0)
NMPVGM-I-35H	0.40	26.80	0.25
	(11.3)	(908.0)	(7.1)
NMPVGM-I-85H	1.60	26.80	0.99
	(45.3)	(908.0)	(28.0)
NMPVGM-I-35H-18M	0.40	26.80	0.25
	(11.3)	(908.0)	(7.1)
NMPVGM-I-85H-18M	1.60	26.80	0.99
	(45.3)	(908.0)	(28.0)

Warnings

Improper selection, misuse, age or malfunction of components used in systems can cause failure in various modes. The system designer is warned to consider the failure modes of all component parts and to provide adequate safeguards to prevent personal injury or damage to equipment or property in the event of such failure modes. System designers and end users are cautioned to consult instruction sheets and specifications available from the factory. The system designer/end user is responsible for verifying that all requirements for the application are met.

Warranty

The products described herein are warranted subject to seller's Standard Terms and Condition of Sale, available at seller's website.

Variable Vacuum Generators

The NVDF Series is a unique Norgren innovation that places the vacuum port and exhaust path inline making a straight-through venturi vacuum generator. These compact generators offer high flow rates, high vacuum levels, and are field adjustable without the need for a separate regulator. Developed for extremely dirty and dusty environments, NVDF generators do not clog, lose suction or require a vacuum filter.



Fast Find Guide

Please note: These products represent only part of the Norgren vacuum range. If you can't see the option you require please contact us.



Variable Vacuum Generators

NVDF Series

Adjustable vacuum level up to 25"Hg, flow 2.00-120.00 SCFM, straight-through non clogging design



Page 104



- » Adjustable vacuum level and flow rate
- » Powerful vacuum up to 25"Hg [847mbar]
- » High flow, up to 120 SCFM [3398 LPM]
- » Energy efficient – customer controlled with high performance to air consumption ratio
- » Safe operation – No electricity needed at the generator and no heat generated
- » Reliable operation – straight-through design with no moving parts

Technical Data

Fluid

Filtered (50 Micron) unlubricated, non-corrosive dry gases

Operating Pressure
Above 50 PSI (3.4bar)

Operating Temperature
-100° to ~ 400° F (-73° to ~204°C)

Materials

Generator Body: Anodized Aluminum

Silencer Body: Varies by Size



	NVDF 10, 15, 20, 25	NVDF 37	NVDF 50	NVDF 75
Supply Line	3/8" (10mm)	1/2" (12mm)	1/2" (12mm)	5/8" (16mm)
Vacuum Line	3/8" (10mm)	5/8" (16mm)	3/4" (19mm) ID hose	1.0" (25mm) ID hose

Note: Tubing size is based on 0.062 wall – polyethylene & polyurethane.

Option selector

Series		Substitute		Material		Substitute	
NVDF (Imperial Thread)				Anodized Aluminum (Standard)		M01	
NVDFM (Metric Thread)		M		303 Stainless Steel		M05	
Size		Substitute		304 Stainless Steel		M06	
NVDF-10		10		316 Stainless Steel		M07	
NVDF-15		15		316L Stainless Steel		M08	
NVDF-20		20		PVC		M09	
NVDF-25		25		PTFE (Teflon®)		M12	
NVDF-37		37		PEEK		M14	
NVDF-50		50		Black Acetal (Delrin®)		M10	
NVDF-75		75		White Acetal (Delrin®)		M11	
Vacuum Level Preset		Substitute		Silencer		Substitute	
(none - factory standard)		XX		None		S00	
Preset (Indicate 10-25"Hg, ex. 25"Hg = P25)				Silencer (for NVDF-10, NVDF-15)		Substitute	
				NST4		S05	
				Silencer (for NVDF-20)		Substitute	
				NST4A		S06	
				Silencer (for NVDF-25)		Substitute	
				NST4A2		S07	
				Silencer (for NVDF-37)		Substitute	
				NST8B		S11	
				Silencer (for NVDF-50)		Substitute	
				NST12C		S20	
				Silencer (for NVDF-75)		Substitute	
				NST16C		S21	

Delrin® is a registered trademark of DuPont. Teflon® is a registered trademark of Chemours.

Accessories

Standard Models	Silencer	Inline Fitting	Swivel Elbow Fitting
			
NVDF-10-PXX-S05M01	NST4 Silencer	124250618	124470618
NVDF-15-PXX-S05M01	NST4 Silencer	124250618	124470618
NVDF-20-PXX-S05M01	NST4 Silencer	124250618	124470618
NVDF-25-PXX-S07M01	NST4A2 Silencer	124250618	124470618
NVDF-37-PXX-S11M01	NST8B Silencer	124250738	124470738
NVDF-50-PXX-S20M01	NST12C Silencer	124250738	124470738
NVDF-75-PXX-S21M01	NST16C Silencer	-	-

Dimensions inches (mm)

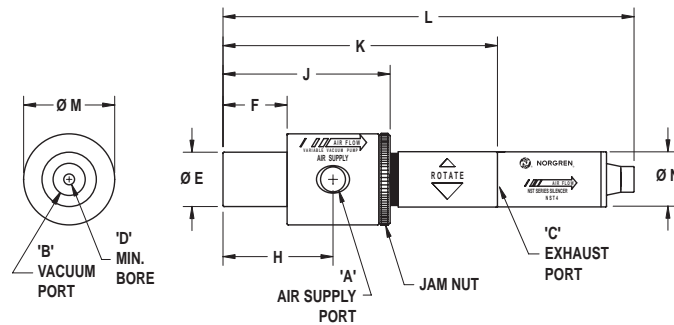

Model	A	B	C	D	E	F	H	J	K	L	M	N	Weight
NVDF-10-P**-S00M** (NVDFM-10-P**-S00M**)	1/8 NPTF (G 1/8)	1/4 NPTF (G 1/4)	1/4 NPTF (G 1/4)	0.13 (3.2)	0.74 (18.8)	0.87 (22.1)	1.50 (38.1)	2.27 (57.7)	3.73 (94.7)	- (-)	1.24 (31.5)	- (-)	3.7oz (105g)
NVDF-10-P**-S05M** (NVDFM-10-P**-S05M**)	1/8 NPTF (G 1/8)	1/4 NPTF (G 1/4)	1/4 NPTF (G 1/4)	0.13 (3.20)	0.74 (18.8)	0.87 (22.1)	1.50 (38.1)	2.27 (57.7)	3.73 (94.7)	5.60 (142.2)	1.24 (31.5)	0.75 (19.1)	4.3oz (122g)
NVDF-15-P**-S00M** (NVDFM-15-P**-S00M**)	1/8 NPTF (G 1/8)	1/4 NPTF (G 1/4)	1/4 NPTF (G 1/4)	0.15 (3.7)	0.74 (18.8)	0.87 (22.1)	1.50 (38.1)	2.27 (57.7)	3.73 (94.7)	- (-)	1.24 (31.5)	- (-)	3.7oz (105g)
NVDF-15-P**-S05M** (NVDFM-15-P**-S05M**)	1/8 NPTF (G 1/8)	1/4 NPTF (G 1/4)	1/4 NPTF (G 1/4)	0.15 (3.7)	0.74 (18.8)	0.87 (22.1)	1.50 (38.1)	2.27 (57.7)	3.73 (94.7)	5.60 (142.2)	1.24 (31.5)	0.75 (19.1)	4.3oz (122g)
NVDF-20-P**-S00M** (NVDFM-20-P**-S00M**)	1/8 NPTF (G 1/8)	1/4 NPTF (G 1/4)	1/4 NPTF (G 1/4)	0.19 (4.8)	0.74 (18.8)	0.87 (22.1)	1.50 (38.1)	2.27 (57.7)	3.73 (94.7)	- (-)	1.24 (31.5)	- (-)	3.7oz (105g)
NVDF-20-P**-S05M** (NVDFM-20-P**-S05M**)	1/8 NPTF (G 1/8)	1/4 NPTF (G 1/4)	1/4 NPTF (G 1/4)	0.19 (4.8)	0.74 (18.8)	0.87 (22.1)	1.50 (38.1)	2.27 (57.7)	3.73 (94.7)	5.60 (142.2)	1.24 (31.5)	0.75 (19.1)	4.3oz (122g)
NVDF-25-P**-S00M** (NVDFM-25-P**-S00M**)	1/8 NPTF (G 1/8)	1/4 NPTF (G 1/4)	1/4 NPTF (G 1/4)	0.27 (6.7)	0.74 (18.8)	0.87 (22.1)	1.50 (38.1)	2.27 (57.7)	3.73 (94.7)	- (-)	1.24 (31.5)	- (-)	3.6oz (102g)
NVDF-25-P**-S07M** (NVDFM-25-P**-S07M**)	1/8 NPTF (G 1/8)	1/4 NPTF (G 1/4)	1/4 NPTF (G 1/4)	0.27 (6.7)	0.74 (18.8)	0.87 (22.1)	1.50 (38.1)	2.27 (57.7)	3.73 (94.7)	6.29 (159.8)	1.24 (31.5)	1.00 (25.4)	5.0oz (142g)
NVDF-37-P**-S00M** (NVDFM-37-P**-S00M**)	3/8 NPTF (G 3/8)	1/2 NPTF (G 1/2)	1/2 NPTF (G 1/2)	0.38 (9.5)	0.99 (25.1)	1.50 (38.1)	2.37 (60.2)	3.45 (87.6)	6.04 (153.4)	- (-)	1.74 (44.2)	- (-)	9.7oz (275g)
NVDF-37-P**-S11M** (NVDFM-37-P**-S11M**)	3/8 NPTF (G 3/8)	1/2 NPTF (G 1/2)	1/2 NPTF (G 1/2)	0.38 (9.5)	0.99 (25.1)	1.50 (38.1)	2.37 (60.2)	3.45 (87.6)	6.04 (153.4)	10.84 (275.3)	1.74 (44.2)	1.25 (31.8)	12.7oz (360g)
NVDF-50-P**-S00M** (NVDFM-50-P**-S00M**)	3/8 NPTF (G 3/8)	1/2 NPTF (G 1/2)	3/4 NPTF (G 3/4)	0.50 (12.7)	1.24 (31.5)	1.50 (38.1)	2.50 (63.5)	3.70 (94.0)	6.06 (153.9)	- (-)	1.97 (50.0)	- (-)	14.3oz (405g)
NVDF-50-P**-S20M** (NVDFM-50-P**-S20M**)	3/8 NPTF (G 3/8)	1/2 NPTF (G 1/2)	3/4 NPTF (G 3/4)	0.50 (12.7)	1.24 (31.5)	1.50 (38.1)	2.50 (63.5)	3.70 (94.0)	6.06 (153.9)	13 (330.2)	1.97 (50.0)	2.00 (50.8)	1lb 6oz (618g)
NVDF-75-P**-S00M** (NVDFM-75-P**-S00M**)	1/2 NPTF (G 1/2)	3/4 NPTF (G 3/4)	1 NPTF (G 1)	0.75 (19.1)	1.49 (37.8)	1.50 (38.1)	2.50 (63.5)	3.70 (94.0)	6.95 (176.5)	- (-)	2.22 (56.4)	- (-)	1lb 3oz (544g)
NVDF-75-P**-S21M** (NVDFM-75-P**-S21M**)	1/2 NPTF (G 1/2)	3/4 NPTF (G 3/4)	1 NPTF (G 1)	0.75 (19.1)	1.49 (37.8)	1.50 (38.1)	2.50 (63.5)	3.70 (94.0)	6.95 (176.5)	13.88 (352.6)	2.22 (56.4)	2.00 (50.8)	1lb 6oz (763g)



Performance Data

Degrees of rotation vs Vacuum Level ("Hg)

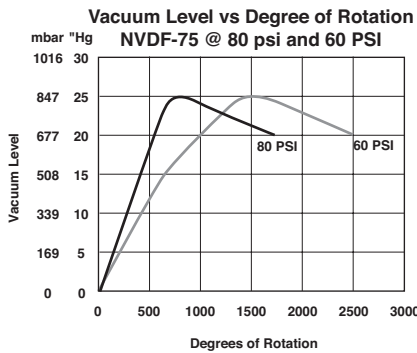
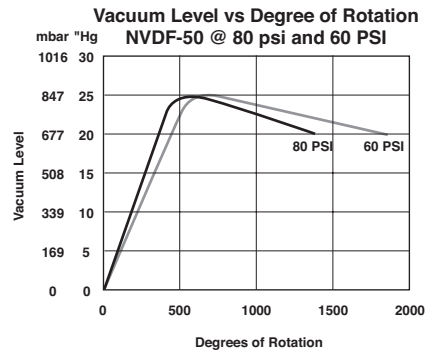
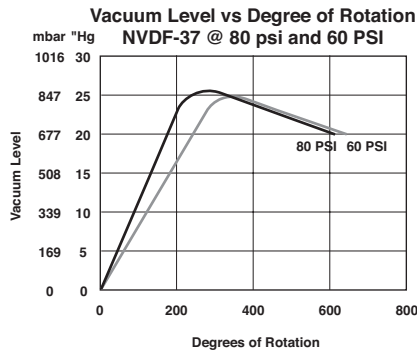
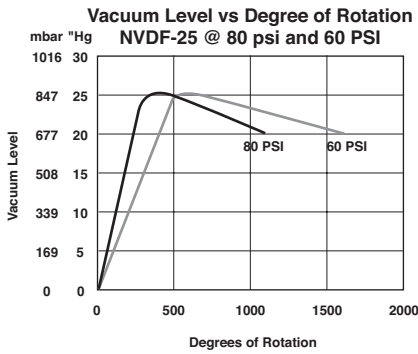
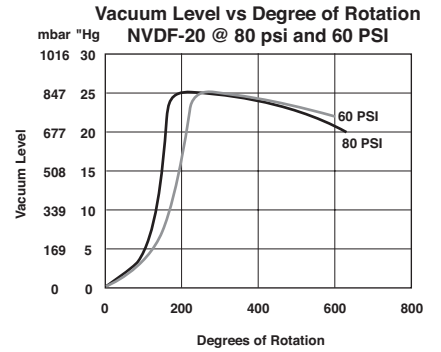
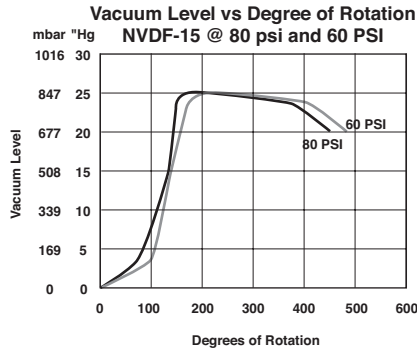
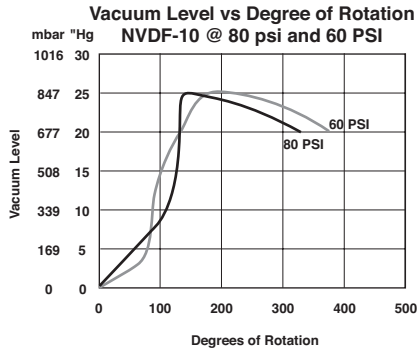

Rotational Chart

Degrees of Rotation vs. Vacuum Level "Hg @ 80 and 60 PSI

Model	Pressure	0"	3"	6"	9"	12"	15"	18"	21"	24"	25"
NVDF-10	@ 80PSI	0	30	60	100	115	120	125	130	134	135
	@ 60PSI	0	60	70	80	90	110	120	140	160	170
NVDF-15	@ 80PSI	0	80	90	105	120	135	145	150	160	165
	@ 60PSI	0	90	100	110	120	130	145	165	19-0	195
NVDF-20	@ 80PSI	0	90	105	120	150	160	170	175	185	190
	@ 60PSI	0	100	135	165	175	185	200	215	235	240
NVDF-25	@ 80PSI	0	100	140	180	195	210	250	275	340	355
	@ 60PSI	0	145	180	205	260	320	370	440	510	530
NVDF-37	@ 80PSI	0	60	90	100	125	155	180	195	220	230
	@ 60PSI	0	65	90	115	165	190	210	255	290	300
NVDF-50	@ 80PSI	0	80	130	170	200	260	340	390	460	490
	@ 60PSI	0	100	170	190	260	360	420	480	560	600
NVDF-75	@ 80PSI	0	95	170	260	350	450	540	630	710	730
	@ 60PSI	0	145	260	350	475	610	730	1080	1370	1440



Performance Data

Model	Vacuum Level "Hg (mbar)	0"Hg (0)	3"Hg (102)	6"Hg (203)	9"Hg (305)	12"Hg (406)	15"Hg (508)	18"Hg (609)	21"Hg (711)	24"Hg (813)	25"Hg (846)
NVDF-10	Vacuum Flow SCFM (L/min)	2.00 (56.6)	1.80 (51.0)	1.60 (45.3)	1.40 (39.6)	1.30 (36.8)	1.20 (34.0)	1.10 (31.2)	0.75 (21.2)	0.25 (7.1)	0.00 (0.0)
	Evacuation time (seconds)	0.00 (0.0)	3.34 (0.1)	7.95 (0.3)	13.6 (0.5)	20.53 (0.7)	28.48 (1.0)	38.74 (1.4)	53.88 (1.9)	84.15 (3.0)	104.94 (3.7)
NVDF-15	Vacuum Flow SCFM (L/min)	3.20 (90.6)	2.80 (79.3)	2.50 (70.8)	2.20 (62.3)	1.80 (51.0)	1.60 (45.3)	1.30 (36.8)	0.90 (25.5)	0.40 (11.3)	0.00 (0.0)
	Evacuation time (seconds)	0.00 (0.0)	2.57 (0.1)	5.90 (0.2)	10.00 (0.4)	15.39 (0.5)	22.06 (0.8)	31.05 (1.1)	46.18 (1.6)	75.69 (2.7)	97.5 (3.4)
NVDF-20	Vacuum Flow SCFM (L/min)	6.00 (169.9)	5.60 (158.6)	5.00 (141.6)	4.20 (118.9)	3.60 (102.0)	3.00 (85.0)	2.60 (73.6)	1.80 (51.0)	0.90 (25.5)	0.00 (0.0)
	Evacuation time (seconds)	0.00 (0.0)	1.03 (0.0)	2.57 (0.1)	4.11 (0.1)	6.41 (0.2)	9.49 (0.3)	13.34 (0.5)	19.50 (0.7)	31.05 (1.1)	38.23 (1.3)
NVDF-25	Vacuum Flow SCFM (L/min)	10.00 (283.2)	9.20 (260.5)	8.30 (235.1)	7.50 (212.4)	6.60 (186.9)	5.80 (164.3)	5.20 (147.3)	3.80 (107.6)	1.30 (36.8)	0.00 (0.0)
	Evacuation time (seconds)	0.00 (0.0)	0.51 (0.0)	1.03 (0.0)	1.80 (0.1)	2.82 (0.1)	4.11 (0.1)	5.90 (0.2)	9.75 (0.3)	17.19 (0.6)	21.55 (0.8)
NVDF-37	Vacuum Flow SCFM (L/min)	30.00 (849.6)	27.00 (764.6)	25.00 (708.0)	23.00 (651.4)	21.00 (594.7)	18.00 (509.8)	16.00 (453.1)	11.00 (311.5)	3.00 (85.0)	0.00 (0.0)
	Evacuation time (seconds)	0.00 (0.0)	0.00 (0.0)	0.51 (0.0)	1.03 (0.0)	1.28 (0.0)	2.05 (0.1)	3.08 (0.1)	4.87 (0.2)	8.47 (0.3)	12.83 (0.5)
NVDF-50	Vacuum Flow SCFM (L/min)	60.00 (1699.2)	52.00 (1472.6)	45.00 (1274.4)	41.00 (1161.1)	38.00 (1076.2)	35.00 (991.2)	28.00 (793.0)	19.00 (538.1)	5.00 (141.6)	0.00 (0.0)
	Evacuation time (seconds)	0.00 (0.0)	0.00 (0.0)	0.21 (0.0)	0.48 (0.0)	0.73 (0.0)	1.08 (0.0)	1.54 (0.1)	2.73 (0.1)	4.45 (0.2)	6.92 (0.2)
NVDF-75	Vacuum Flow SCFM (L/min)	120.00 (3398.4)	99.00 (2803.7)	83.00 (2350.6)	74.00 (2095.7)	62.00 (1755.8)	51.00 (1444.3)	46.00 (1302.7)	34.00 (962.9)	9.00 (254.9)	0.00 (0.0)
	Evacuation time (seconds)	0.00 (0.0)	0.00 (0.0)	0.00 (0.0)	0.00 (0.0)	0.12 (0.0)	0.38 (0.0)	0.7 (0.0)	1.09 (0.0)	3.07 (0.1)	5.38 (0.2)

NVDF Series – Vacuum Flow vs. Vacuum Level

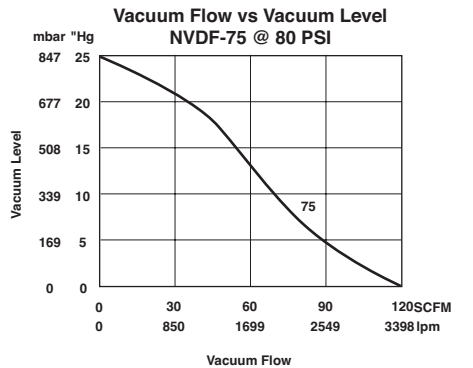
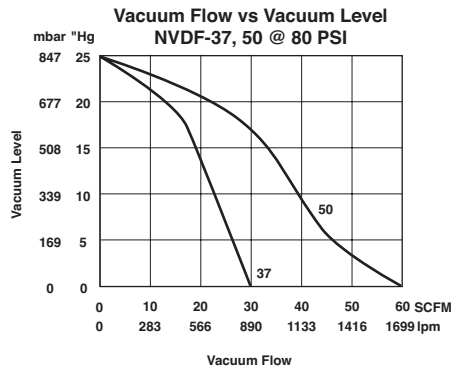
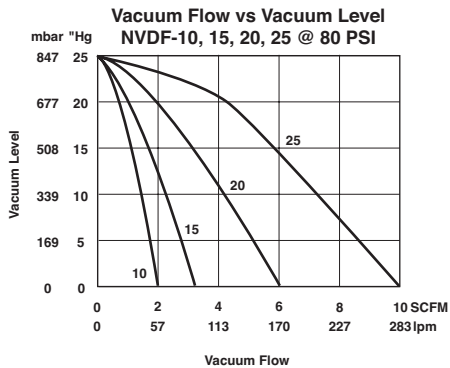

NVDF Series – Vacuum Level vs. Air Consumption

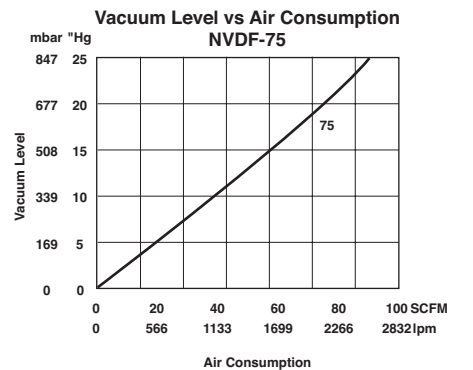
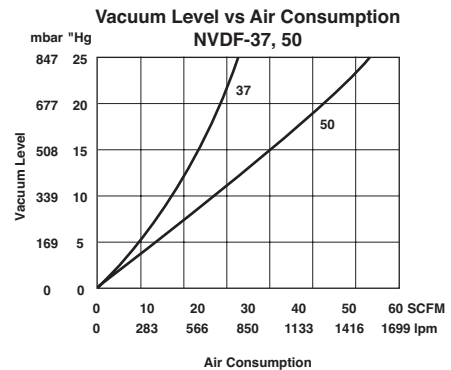
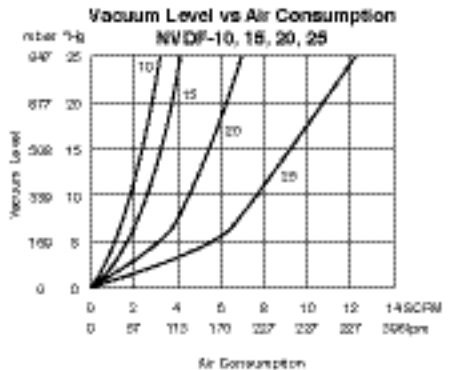

Noise Levels @ 80 PSI

Model	Silencer	With Silencer		Without Silencer	
		Open Flow	Sealed Vacuum	Open Flow	Sealed Vacuum
NVDF-10-P**-S05M**	NST4	70db	68db	88db	76db
NVDF-15-P**-S05M**	NST4	74db	68db	88db	90db
NVDF-20-P**-S05M**	NST4	78db	80db	86db	100db
NVDF-20-P**-S06M**	NST4A	76db	80db	86db	100db
NVDF-25-P**-S06M**	NST4A	82db	80db	90db	100db
NVDF-25-P**-S07M**	NST4A2	84db	82db	90db	100db
NVDF-37-P**-S11M**	NST8B	88db	82db	102db	104db
NVDF-50-P**-S20M**	NST12C	82db	78db	96db	100db
NVDF-75-P**-S21M**	NST16C	98db	88db	112db	108db

Noise levels at 80PSI

Operating Instructions

1. Loosen jam nut by rotating counter-clockwise. (Typically, unless pinned, your NVDF will arrive completely closed.)
2. Rotate exhaust body clockwise until closed, jam nut should be loose on exhaust body.
3. Attach air line to air supply port and vacuum line to vacuum port or connect cup to port. See chart for minimum recommended line sizes.
4. Turn on compressed air.
5. Rotate exhaust body counter-clockwise to the desired vacuum level using rotation chart on page 107.

Charts are based on 80 PSI [5.5 bar] and 60 PSI [4.1 bar] to provide a starting point. Generators will achieve maximum vacuum levels at any pressure above 50 PSI [3.4 bar] (pressure regulator is not required). For a more precise reading, Norgren recommends the use of a NVG-150 Vacuum Gauge to measure and/or set vacuum level. Consult factory.

6. After achieving desired vacuum level, tighten jam nut by rotating clockwise.

Note 1: Further rotation will increase the vacuum level, while the flow remains constant.

Note 2: NVDF-37 and larger, it may be necessary to turn compressed air off while making adjustments to relieve pressure on threads and make rotating easier.

Note 3: "Preset" NVDF's are permanently locked at the factory at a customer specified vacuum level and are not adjustable.

Note 4: "Preset" generators are not returnable.

Warnings

Improper selection, misuse, age or malfunction of components used in systems can cause failure in various modes. The system designer is warned to consider the failure modes of all component parts and to provide adequate safeguards to prevent personal injury or damage to equipment or property in the event of such failure modes. System designers and end users are cautioned to consult instruction sheets and specifications available from the factory. The system designer/end user is responsible for verifying that all requirements for the application are met.

Warranty

The products described herein are warranted subject to seller's Standard Terms and Condition of Sale, available at seller's website.

[High Flow Vacuum/ Blower Generators]

NCDF Series air amplifiers generate high vacuum flow, overcoming leaks inherent in handling porous and irregular shaped objects. The NCDF Series generates high output flow using a small volume of compressed air. This efficient use of air makes NCDF air amplifiers a cost effective alternative to electric blowers or raw compressed air.



Fast Find Guide

Please note: These products represent only part of the Norgren vacuum range. If you can't see the option you require please contact us.



High Flow Vacuum/Blower Generators

NCDF Series

Vacuum level up to 9"Hg,
flow 12.00-330.00 SCFM,
air amplifier blower



Page 112



- » Excellent for picking porous and irregular shaped materials
- » Air amplification capability
- amplify air by 40:1 ratio
- » Field adjustable for individual applications
- » Energy efficient, unlike regenerative blowers that must run continuously
- » Ideal for adverse operating conditions

Technical Data

Fluid

Filtered (50 Micron) unlubricated, non-corrosive dry gases

Operating Pressure

Above 50 PSI (3.4bar)

Operating Temperature

-100° to ~ 400° F (-73° to ~ 204°C)

Materials

Generator Body: Anodized Aluminum

Silencer Body : Varies by Size



	NCDF20, 37	NCDF50, 75, 100, 150, 200
Supply Line	1/4" (4mm)	3/8" (10mm)
Vacuum Line	Minimum orifice 0.125"	Minimum orifice 0.250"

Option selector

Series	Substitute	NCDF - - -S M	Material	Substitute
NCDF (Imperial Thread)			Anodized Aluminum (Standard)	M01
NCDFM (Metric Thread)	M		303 Stainless Steel	M05
Size	Substitute		304 Stainless Steel	M06
NCDF-20	20		316 Stainless Steel	M07
NCDF-20H	20H		316L Stainless Steel	M08
NCDF-37H	37H		PVC	M09
NCDF-50H	50H		Black Acetal (Delrin®)	M10
NCDF-75H	75H		White Acetal (Delrin®)	M11
NCDF-100H	100H		Silencer**	Substitute
NCDF-150H	150H		None	S00
NCDF-200H	200H		Silencer (for NCDF-20)	Substitute
NPT Exhaust Port Threads	Substitute		NST4AX	S14
Without Exhaust Port Threads	(blank)		Silencer (for NCDF-37)	Substitute
With Exhaust Port Threads (Required for silencer)	E*		NST6BX	S16
			Silencer (for NCDF-50, 75)	Substitute
			NST16FC	S18
			Silencer (for NCDF-100)	Substitute
			NST24FC	S19
			Silencer (for NCDF-150)	Substitute
			NST2020	S22

**Silencer not available for NCDF200H

***EPT not required for NST2020

Delrin® is a registered trademark of DuPont.

Accessories

Standard Models	Inline Fitting	Swivel Elbow Fitting
NCDF-20-E-S00M01	124250418	124470418
NCDF-20H-E-S00M01	124250418	124470418
NCDF-37H-S00M01	124250418	124470418
NCDF-50H-S00M01	124250428	124470628
NCDF-75H-S00M01	124250628	124470628
NCDF-100H-S00M01	124250628	124470628
NCDF-150H-S00M01	124250638	124470638

Dimensions inches (mm)

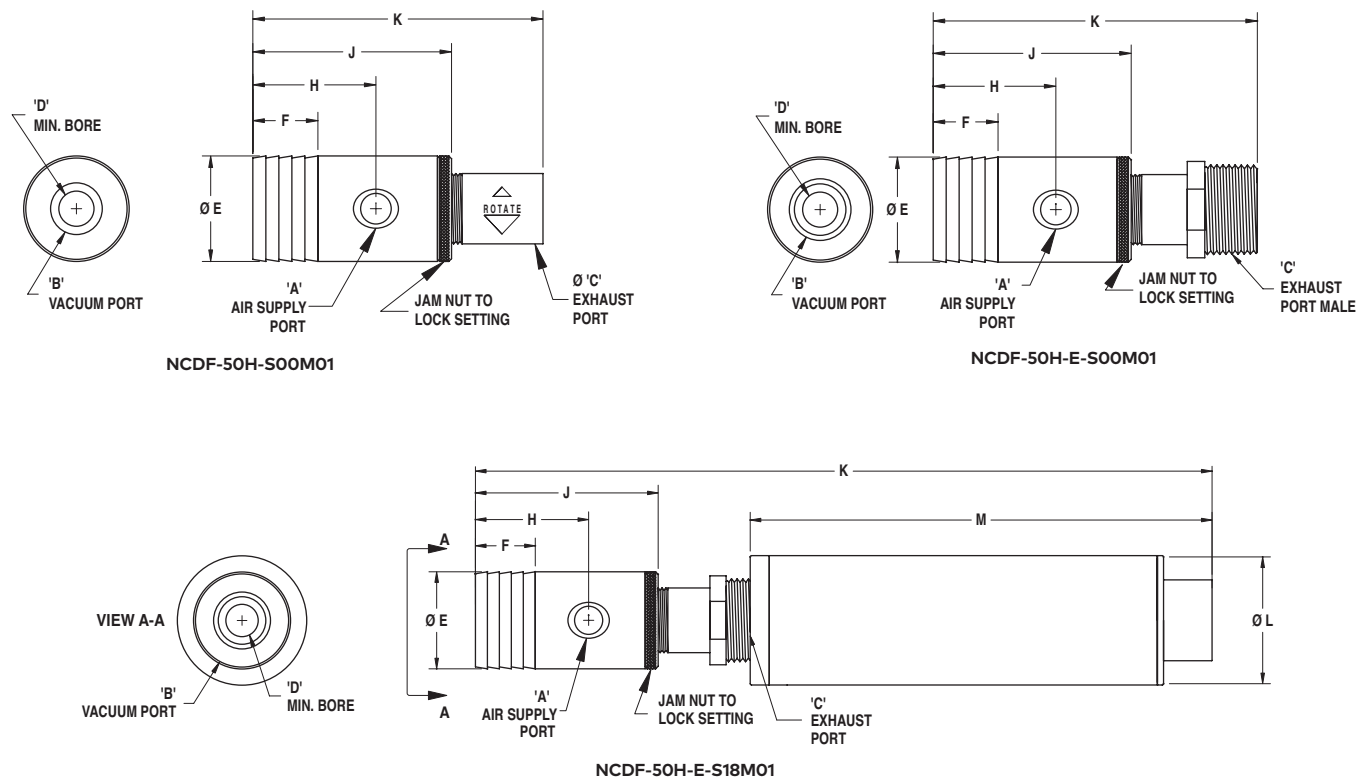



Dimensions inches (mm)

Model	A	B	C	D	E	F	H	J	K	L	M	Weight oz (g)
NCDF-20-E-S00M** (NCDFM-20-E-S00M**)	1/8 NPTF (G 1/8)	- (-)	1/4 NPTF (G 1/4)	0.25 (6.4)	1.25 (31.8)	- (-)	0.44 (11.2)	1.13 (28.7)	2.10 (53.3)	- (-)	- (-)	2.1 oz (60 grams)
NCDF-20-E-S14M** (NCDFM-20-E-S14M**)	1/8 NPTF (G 1/8)	- (-)	1/4 NPTF (G 1/4)	0.25 (6.4)	1.25 (31.8)	- (-)	0.44 (11.2)	1.13 (28.7)	5.40 (137.2)	1.00 (25.4)	3.57 (90.7)	3.7 oz (105 grams)
NCDF-20H-E-S00M** (NCDFM-20H-E-S00M**)	1/8 NPTF (G 1/8)	3/8 NPTF (G 3/8)	1/4 NPTF (G 1/4)	0.25 (6.4)	1.25 (31.8)	0.76 (19.3)	1.21 (30.7)	1.87 (47.5)	2.85 (72.4)	- (-)	- (-)	3.1 oz (88 grams)
NCDF-20H-E-S14M** (NCDFM-20H-E-S14M**)	1/8 NPTF (G 1/8)	3/8 NPTF (G 3/8)	1/4 NPTF (G 1/4)	0.25 (6.4)	1.25 (31.8)	0.76 (19.3)	1.21 (30.7)	1.87 (47.5)	6.15 (156.2)	1.00 (25.4)	3.57 (90.7)	5.2 oz (147 grams)
NCDF-37H-S00M** (NCDFM-37H-S00M**)	1/8 NPTF (G 1/8)	3/8 NPTF (G 3/8)	0.69 (17.5)	0.38 (9.5)	1.25 (31.8)	0.76 (19.3)	1.21 (30.7)	1.87 (47.5)	2.85 (72.4)	- (-)	- (-)	3.1 oz (88 grams)
NCDF-37H-E-S00M** (NCDFM-37H-E-S00M**)	1/8 NPTF (G 1/8)	3/8 NPTF (G 3/8)	3/8 NPTF (G 3/8)	0.38 (9.5)	1.25 (31.8)	0.76 (19.3)	1.21 (30.7)	1.87 (47.5)	2.85 (72.4)	- (-)	- (-)	3.1 oz (88 grams)
NCDF-37H-E-S16M** (NCDFM-37H-E-S16M**)	1/8 NPTF (G 1/8)	3/8 NPTF (G 3/8)	3/8 NPTF (G 3/8)	0.38 (9.5)	1.25 (31.8)	0.76 (19.3)	1.21 (30.7)	1.87 (47.5)	7.43 (188.7)	1.25 (31.8)	4.80 (121.9)	6.3 oz (179 grams)
NCDF-50H-S00M** (NCDFM-50H-S00M**)	1/4 NPTF (G 1/4)	1/2 NPTF (G 1/2)	0.99 (25.1)	0.50 (12.7)	1.49 (37.8)	0.93 (23.6)	1.75 (44.5)	2.83 (71.9)	4.13 (104.9)	- (-)	- (-)	6.3 oz (179 grams)
NCDF-50H-E-S00M** (NCDFM-50H-E-S00M**)	1/4 NPTF (G 1/4)	1/2 NPTF (G 1/2)	1 NPT (G 1)	0.50 (12.7)	1.49 (37.8)	0.93 (23.6)	1.75 (44.5)	2.83 (71.9)	4.63 (117.6)	- (-)	- (-)	7.3 oz (207 grams)
NCDF-50H-E-S18M** (NCDFM-50H-E-S18M**)	1/4 NPTF (G 1/4)	1/2 NPTF (G 1/2)	1 NPT (G 1)	0.50 (12.7)	1.49 (37.8)	0.93 (23.6)	1.75 (44.5)	2.83 (71.9)	11.39 (289.3)	2.00 (50.8)	7.12 (180.8)	14.9 oz (422 grams)
NCDF-75H-S00M** (NCDFM-75H-S00M**)	1/4 NPTF (G 1/4)	1 NPTF (G 1)	1.23 (31.2)	0.75 (19.1)	1.97 (50.0)	0.93 (23.6)	1.75 (44.5)	2.83 (71.9)	4.13 (104.9)	- (-)	- (-)	10.1 oz (286 grams)
NCDF-75H-E-S00M** (NCDFM-75H-E-S00M**)	1/4 NPTF (G 1/4)	1 NPTF (G 1)	1 NPTF (G 1)	0.75 (19.1)	1.97 (50.0)	0.93 (23.6)	1.75 (44.5)	2.83 (71.9)	5.02 (127.5)	- (-)	- (-)	10.9 oz (309 grams)
NCDF-75H-E-S18M** (NCDFM-75H-E-S18M**)	1/4 NPTF (G 1/4)	1 NPTF (G 1)	1 NPTF (G 1)	0.75 (19.1)	1.97 (50.0)	0.93 (23.6)	1.75 (44.5)	2.83 (71.9)	11.7 (297.2)	2.00 (50.8)	7.12 (180.8)	1lb 2oz (519 grams)
NCDF-100H-S00M** (NCDFM-100H-S00M**)	1/4 NPTF (G 1/4)	1 1/4 NPTF (G 1 1/4)	1.48 (37.6)	1.00 (25.4)	2.22 (56.4)	0.93 (23.6)	1.75 (44.5)	2.83 (71.9)	4.13 (104.9)	- (-)	- (-)	11.5 oz (326 grams)
NCDF-100H-E-S00M** (NCDFM-100H-E-S00M**)	1/4 NPTF (G 1/4)	1 1/4 NPTF (G 1 1/4)	1 1/2 NPTF (G 1 1/2)	1.00 (25.4)	2.22 (56.4)	0.93 (23.6)	1.75 (44.5)	2.83 (71.9)	4.64 (117.9)	- (-)	- (-)	13.2 oz (374 grams)
NCDF-100H-E-S19M** (NCDFM-100H-E-S19M**)	1/4 NPTF (G 1/4)	1 1/4 NPTF (G 1 1/4)	1 1/2 NPTF (G 1 1/2)	1.00 (25.4)	2.22 (56.4)	0.93 (23.6)	1.75 (44.5)	2.83 (71.9)	12.00 (304.8)	2.00 (50.8)	7.85 (199.4)	1lb 5oz (595 grams)
NCDF-150H-S00M** (NCDFM-150H-S00M**)	3/8 NPTF (G 3/8)	2 NPTF (G 2)	1.99 (50.5)	1.50 (38.1)	2.72 (69.1)	0.93 (23.6)	1.75 (44.5)	2.83 (71.9)	4.13 (104.9)	- (-)	- (-)	13.3 oz (377 grams)
NCDF-150H-E-S00M** (NCDFM-150H-E-S00M**)	3/8 NPTF (G 3/8)	2 NPTF (G 2)	2 NPTF (G 2)	1.5 (38.1)	2.72 (69.1)	0.93 (23.6)	1.75 (44.5)	2.83 (71.9)	4.76 (120.9)	- (-)	- (-)	1 lb (454 grams)
NCDF-150H-S22M** (NCDFM-150H-S22M**)	3/8 NPTF (G 3/8)	2 NPTF (G 2)	Slip fit (Slip Fit)	1.5 (38.1)	2.72 (69.1)	0.93 (23.6)	1.75 (44.5)	2.83 (71.9)	17.00 (431.8)	3.46 (87.9)	13.62 (345.9)	1lb 8oz (692 grams)
NCDF-200H-S00M** (NCDFM-200H-S00M**)	3/8 NPTF (G 3/8)	2 1/2 NPTF (N/A)	2.49 (63.2)	2.00 (50.8)	3.22 (81.8)	0.93 (23.6)	1.75 (44.5)	2.83 (71.9)	4.13 (104.9)	- (-)	- (-)	1lb 0.5oz (468 grams)

Performance Data

Model	Air Consumption	Imperial	Metric
NCDF-20	Vacuum Level "Hg [mbar]	9	305
	Vacuum Flow SCFM [lpm]	12	340
	Maximum Exhaust Output SCFM [lpm]	16	453
NCDF-20H	Vacuum Level "Hg [mbar]	9	305
	Vacuum Flow SCFM [lpm]	12	340
	Maximum Exhaust Output SCFM [lpm]	16	453
NCDF-37H	Vacuum Level "Hg [mbar]	8	271
	Vacuum Flow SCFM [lpm]	28	793
	Maximum Exhaust Output SCFM [lpm]	36	1019
NCDF-50H	Vacuum Level "Hg [mbar]	7	237
	Vacuum Flow SCFM [lpm]	55	1557
	Maximum Exhaust Output SCFM [lpm]	70	1982
NCDF-75H	Vacuum Level "Hg [mbar]	5	169
	Vacuum Flow SCFM [lpm]	110	3115
	Maximum Exhaust Output SCFM [lpm]	140	3964
NCDF-100H	Vacuum Level "Hg [mbar]	3	102
	Vacuum Flow SCFM [lpm]	130	3681
	Maximum Exhaust Output SCFM [lpm]	180	5097
NCDF-150H	Vacuum Level "Hg [mbar]	3	102
	Vacuum Flow SCFM [lpm]	250	7079
	Maximum Exhaust Output SCFM [lpm]	300	8495
NCDF-200H	Vacuum Level "Hg [mbar]	1	34
	Vacuum Flow SCFM [lpm]	330	9345
	Maximum Exhaust Output SCFM [lpm]	390	11044

NCDF-20/20H Series

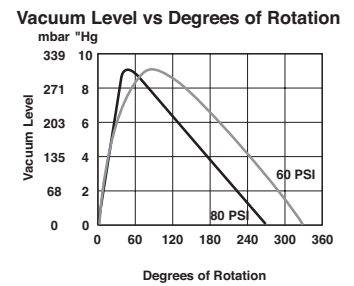
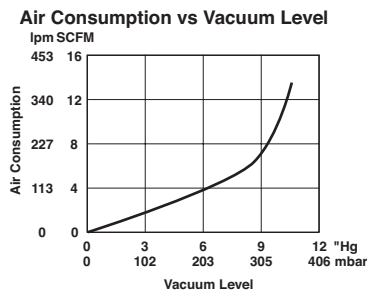
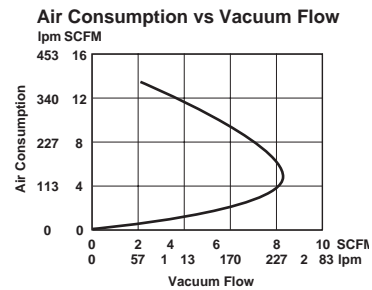

Note: Performance Charts represent average performance data. For reference only.



Performance Data

NCDF-37H Series

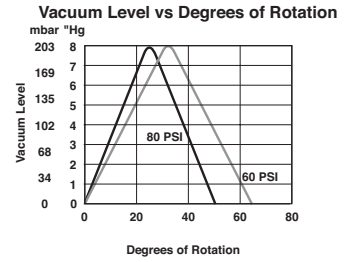
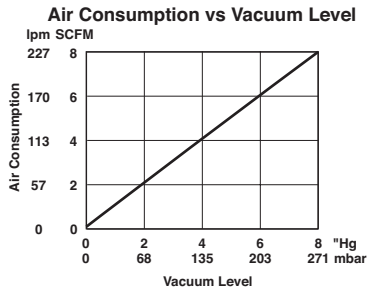
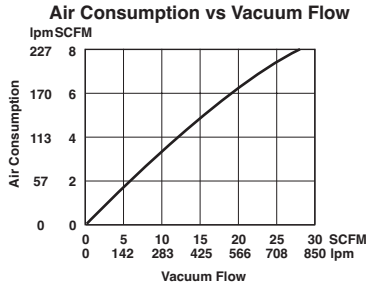

NCDF-50H Series

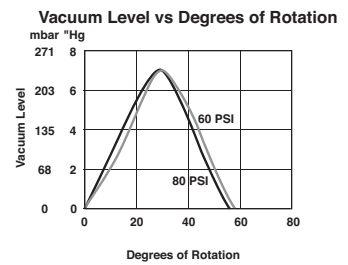
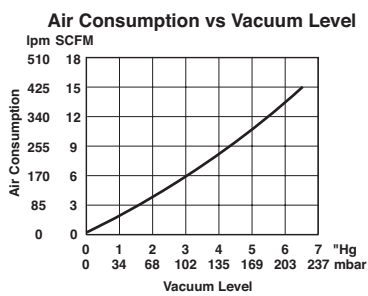
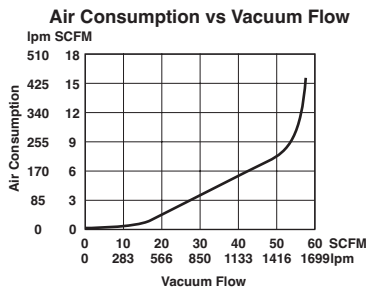

NCDF-75H Series

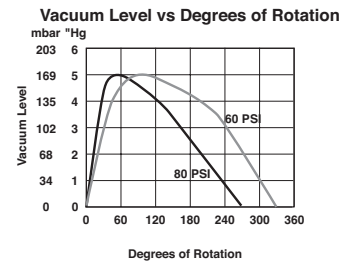
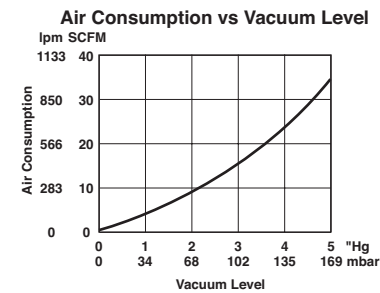
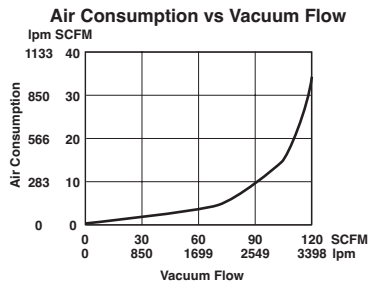

NCDF-100H Series

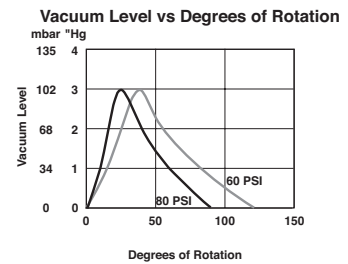
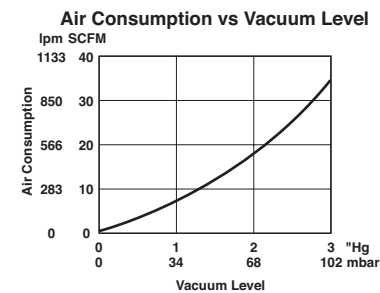
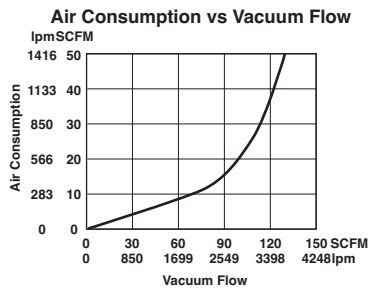

Note: Performance Charts represent average performance data. For reference only.

Performance Data

NCDF-150H Series

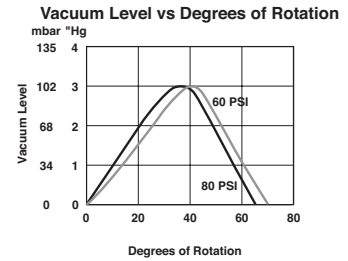
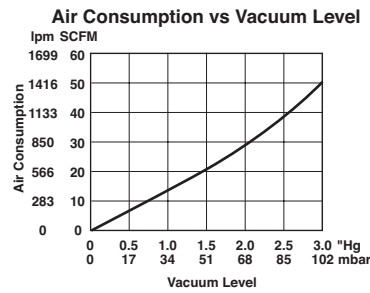
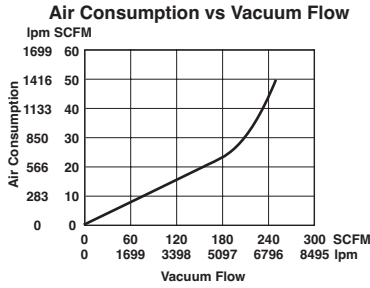

NCDF 200H Series

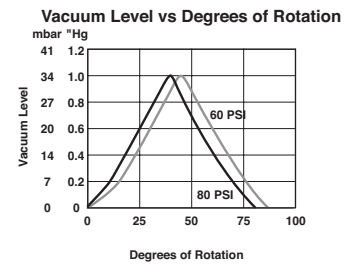
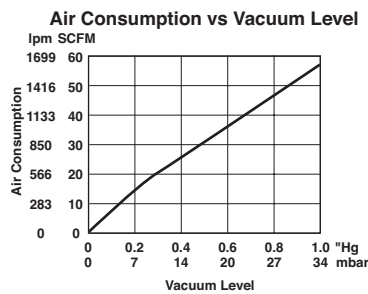
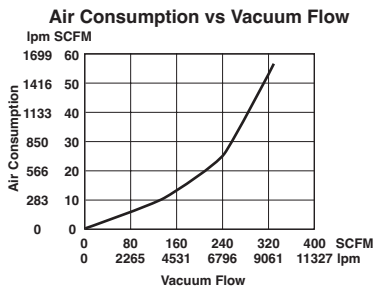

Note: Performance Charts represent average performance data. For reference only.

Noise Levels @ 80 PSI

Model	Silencer	With Silencer		Without Silencer	
		Open Flow	Sealed Vacuum	Open Flow	Sealed Vacuum
NCDF-20-E-S14M01	NST4AX	86dB	78dB	98dB	94dB
NCDF-20H-E-S14M01	NST4AX	86dB	78dB	98dB	94dB
NCDF-37H-E-S16M01	NST6BX	78dB	70dB	98dB	90dB
NCDF-50H-E-S18M01	NST16FC	78dB	72dB	100dB	92dB
NCDF-75H-E-S18M01	NST16FC	78dB	70dB	100dB	92dB
NCDF-100H-E-S19M01	NST24FC	82dB	72dB	102dB	92dB
NCDF-150H-E-S22M01	NST2020	88dB	72dB	106dB	96dB
NCDF-200H-S00M01	N/A	N/A	N/A	108dB	98dB

Noise levels at 80PSI

Warnings

Improper selection, misuse, age or malfunction of components used in systems can cause failure in various modes. The system designer is warned to consider the failure modes of all component parts and to provide adequate safeguards to prevent personal injury or damage to equipment or property in the event of such failure modes. System designers and end users are cautioned to consult instruction sheets and specifications available from the factory. The system designer/end user is responsible for verifying that all requirements for the application are met.

Warranty

The products described herein are warranted subject to seller's Standard Terms and Condition of Sale, available at seller's website.

Material Transfer Vacuum Generators

The NDF Series of high flow material conveying vacuum generators provide a simple, reliable, and cost effective method of in-line transfer of bulk materials, complex shapes, individual objects, selvedge. The NDF generator's unique capability to create instantaneous vacuum flow and high air velocity, combined with its straight-through, smooth bore design allows material to pass directly through the generator at high speeds without interference or clogging.



Straight through design

Materials pass directly through the generator

Fast Find Guide

Please note: These products represent only part of the Norgren vacuum range. If you can't see the option you require please contact us.



Material Transfer Vacuum Generators

NDF Series

Vacuum level up to 11"Hg,
flow 4.00-600.00 SCFM, for
bulk material conveyance



Page 120



- » Easily transfer a wide variety of materials
- » Efficient – instant on and off, for low operating costs
- » Fast response – installs close to vacuum point
- » Easy to install – connect tubing to the vacuum and exhaust ports, and supply compressed air
- » Safe operation – no electricity needed at the generator
- » Ideal for adverse operating conditions

Technical Data

Fluid

Filtered (50 Micron) unlubricated, non-corrosive dry gases

Operating Pressure

Input pressure of 40 PSI or less is sufficient to move most bulk materials and individual objects

Supply Pressure

Regulate the supply pressure to develop the necessary transfer speed of the application

Operating Temperature

-100° to ~ 400° F (-73° to ~ 204°C)

Materials

Generator Body: Anodized Aluminum



Standard Models

Part Number	Inline Fitting	Swivel Elbow Fitting	Recommended Air Supply Line	Recommended Transfer Hose
				
NDF13-VSES-M01	124250418	124470418	1/4"	1/2" ID
NDF23-VSES-M01	124250418	124470418	1/4"	3/4" ID
NDF36-VSES-M01	124250618	124470618	3/8"	3/4" ID
NDF56-VSES-M01	124250628	124470628	3/8"	1" ID
NDF76-VSES-M01	124250738	124470738	1/2"	1 1/4" ID
NDF106-VSES-M01	124250738	124470738	1/2"	1 1/2" ID
NDF126-VSES-M01	124250738	124470738	1/2"	1 3/4" ID
NDF156-VSES-M01	124250738	124470738	1/2"	2" ID
NDF206-VSES-M01	124250738	124470738	1/2"	2 1/2" ID

Option selector

Series	Substitute
NDF (Imperial Thread)	
NDFM (Metric Thread)	M

Size	Substitute
NDF13	13
NDF23	23
NDF36	36
NDF56	56
NDF76	76
NDF106	106
NDF126	126
NDF156	156
NDF206	206
NDF306	306
NDF4012	4012

Vacuum Port Thread Options	Substitute
No thread (standard)	VS
Female (internal) thread	VF
Male (external) thread	VM

Exhaust Port Thread Options	Substitute
Exhaust port - no thread (standard)	ES
Exhaust port female - internal thread	EF
Exhaust port male (external) thread	EM

Material	Substitute
Anodized Aluminum (Standard)	M01
*303 Stainless Steel	M05
304 Stainless Steel	M06
316 Stainless Steel	M07
316L Stainless Steel	M08
PVC	M09
Black Acetal (Delrin [®])	M10
White Acetal (Delrin [®])	M11
PTFE (Teflon [®])	M12
PEEK	M14

*303 stainless steel only available for NDF-13, 23, and 36 generators
 Delrin[®] is a registered trademark of DuPont. Teflon[®] is a registered trademark of Chemours.



Dimensions inches (mm)

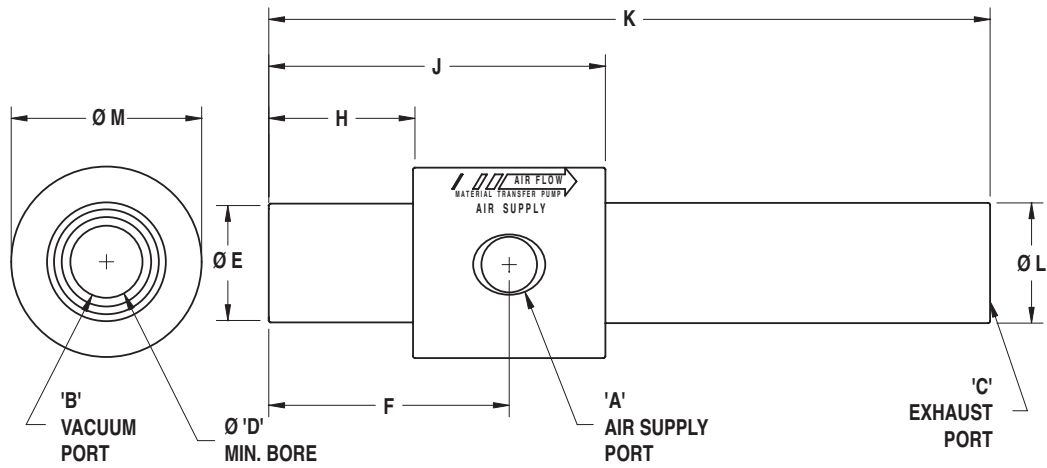

Model	A	B Optional Male Vacuum Thread	C Optional Male Exhaust Thread	B Optional Female Vacuum Thread	C Optional Female Vacuum Thread	D Minimum Bore	E	F	H	J	K	L	M	Weight lb / oz (kg)
NDF13 (NDFM13)	1/8 NPTF (G1/8)	1/8 NPT (G1/8)	1/8 NPT (G1/8)	1/8 NPT (G1/8)	1/8 NPT (G1/8)	0.15 (3.8)	0.48 (12.2)	1.00 (25.4)	0.50 (12.7)	1.50 (38.1)	3.00 (76.2)	0.49 (12.4)	0.99 (25.1)	1.5oz (42.5g)
NDF23 (NDFM23)	1/8 NPTF (G1/8)	3/8 NPT (G3/8)	3/8 NPT (G3/8)	1/4 NPT (G1/4)	1/4 NPT (G1/4)	0.25 (6.4)	0.73 (18.4)	1.25 (31.8)	0.75 (19.1)	1.75 (44.5)	3.50 (88.9)	0.74 (18.8)	1.24 (31.5)	3.2oz (91g)
NDF36 (NDFM36)	1/8 NPTF (G1/8)	3/8 NPT (G3/8)	3/8 NPT (G3/8)	1/4 NPT (G1/4)	1/4 NPT (G1/4)	0.38 (9.7)	0.73 (18.4)	1.25 (31.8)	0.75 (19.1)	1.75 (44.5)	3.50 (88.9)	0.74 (18.8)	1.24 (31.5)	2.8oz (79g)
NDF56 (NDFM56)	1/4 NPTF (G1/4)	1/2 NPT (G1/2)	1/2 NPT (G1/2)	1/2 NPT (G1/2)	1/2 NPT (G1/2)	0.50 (12.7)	0.99 (25.0)	1.62 (41.1)	1.00 (25.4)	2.25 (57.2)	5.50 (139.7)	1.00 (25.4)	1.48 (37.6)	6.2oz (176g)
NDF76 (NDFM76)	3/8 NPTF (G3/8)	3/4 NPT (G3/4)	3/4 NPT (G3/4)	3/4 NPT (G3/4)	3/4 NPT (G3/4)	0.75 (19.1)	1.24 (31.4)	2.50 (63.5)	1.50 (38.1)	3.50 (88.9)	7.50 (190.5)	1.25 (31.8)	1.98 (50.1)	13.4oz (380g)
NDF106 (NDFM106)	3/8 NPTF (G3/8)	1 NPT (G1)	1 NPT (G1)	1 NPT (G1)	1 NPT (G1)	1.00 (25.4)	1.46 (37.1)	2.50 (63.5)	1.50 (38.1)	3.50 (88.9)	7.50 (190.5)	1.48 (37.6)	2.23 (56.6)	1lb 5oz (468g)
NDF126 (NDFM126)	3/8 NPTF (G3/8)	*	*	*	*	1.25 (31.8)	1.71 (43.4)	2.50 (63.5)	1.50 (38.1)	3.50 (88.9)	7.50 (190.5)	1.73 (43.9)	2.47 (62.7)	1lb 3oz (541g)
NDF156 (NDFM156)	3/8 NPTF (G3/8)	1 1/2 NPT (G1 1/2)	1 1/2 NPT (G1 1/2)	1 1/4 NPT (G1 1/4)	1 1/4 NPT (G1 1/4)	1.50 (38.1)	1.96 (49.8)	2.50 (63.5)	1.50 (38.1)	3.50 (88.9)	7.50 (190.5)	1.98 (50.3)	2.73 (69.3)	1lb 5oz (607g)
NDF206 (NDFM206)	3/8 NPTF (G3/8)	2 NPT (G2)	2 NPT (G2)	2 NPT (G2)	2 NPT (G2)	2.00 (50.8)	2.46 (62.5)	2.50 (63.5)	1.50 (38.1)	3.50 (88.9)	7.50 (190.5)	2.48 (63.0)	3.23 (82.0)	1lb 9oz (777g)
NDF306 (NDFM306)	1/2 NPTF (G1/2)	N/A (N/A)	N/A (N/A)	N/A (N/A)	N/A (N/A)	3.00 (76.2)	3.46 (87.9)	2.50 (63.5)	1.50 (38.1)	3.50 (88.9)	8.50 (215.9)	3.48 (88.4)	4.47 (113.5)	3lbs 6oz (1.4kgs)
NDF4012 (NDFM4012)	3/4 NPTF (G3/4)	N/A (N/A)	N/A (N/A)	N/A (N/A)	N/A (N/A)	4.00 (101.6)	4.89 (124.2)	3.25 (82.6)	2.00 (50.8)	4.50 (114.3)	9.50 (241.3)	4.95 (125.7)	5.95 (151.1)	6lbs 11oz (3kgs)

*Note: Consult factory

Performance Data

NDF13, NDF23, NDF36

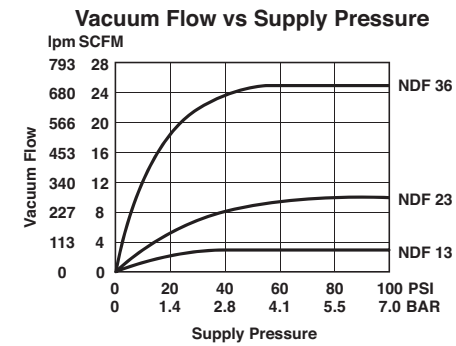
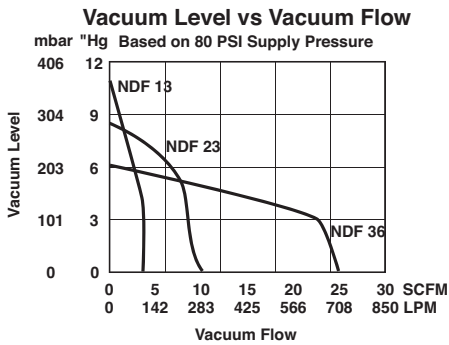
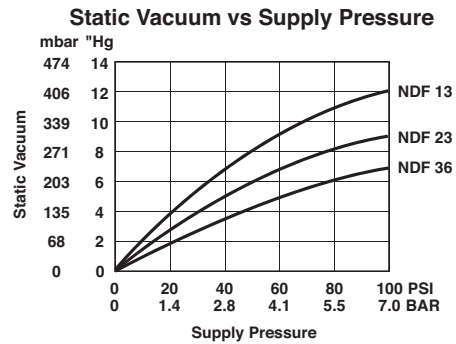
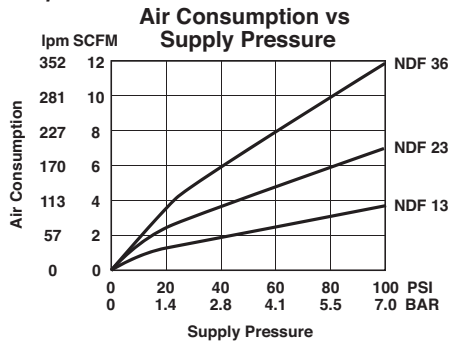

NDF56

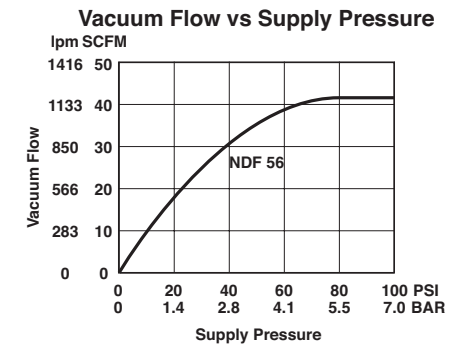
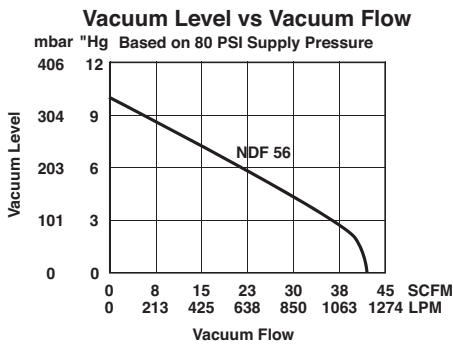
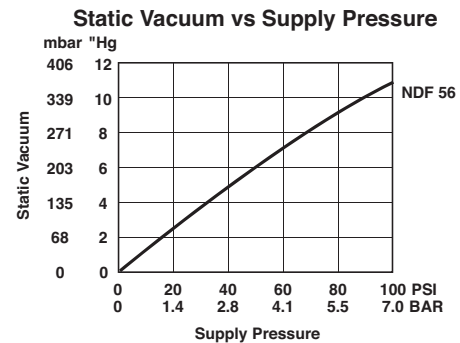

Operating Note: Above 40 PSI [2.7 bar], the increased energy consumed through rising air consumption is converted into increased vacuum level while vacuum flow stays constant. It is the vacuum flow that provides the motive force for the materials to be transferred. Higher vacuum levels are useful when lifting high molecular weight bulk materials and heavy individual objects long distances vertically.

Note: Performance Charts represent average performance data. For reference only.



Performance Data

NDF76, NDF106, NDF126

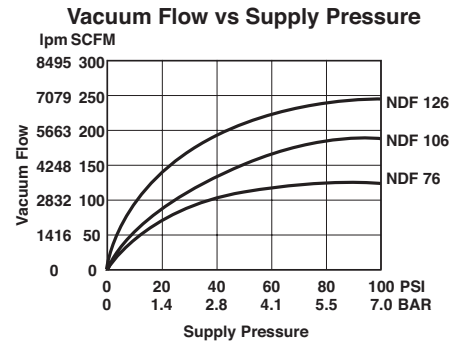
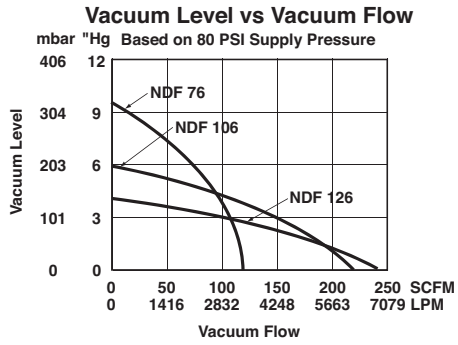
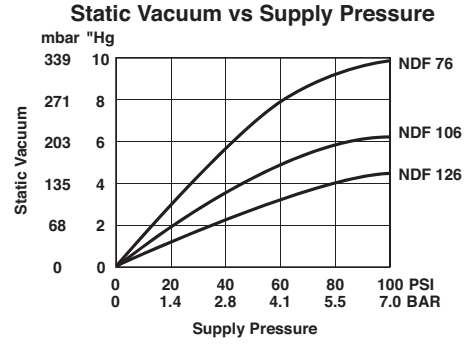
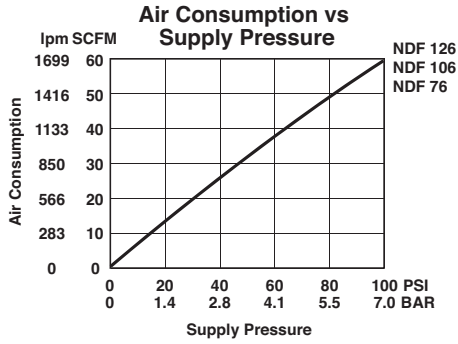

Operating Note: Above 40 PSI [2.7 bar], the increased energy consumed through rising air consumption is converted into increased vacuum level while vacuum flow stays constant. It is the vacuum flow that provides the motive force for the materials to be transferred. Higher vacuum levels are useful when lifting high molecular weight bulk materials and heavy individual objects long distances vertically.

Note: Performance Charts represent average performance data. For reference only.

Performance Data

NDF156, NDF206

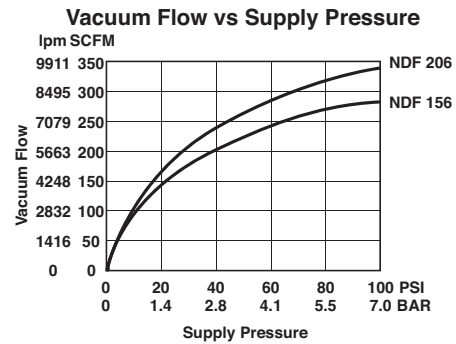
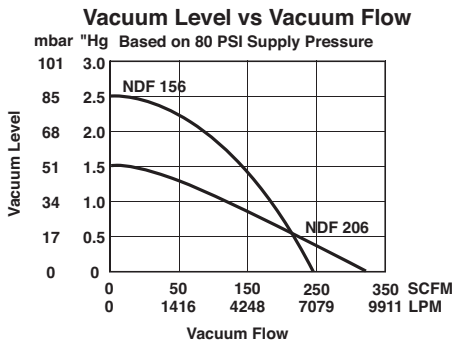
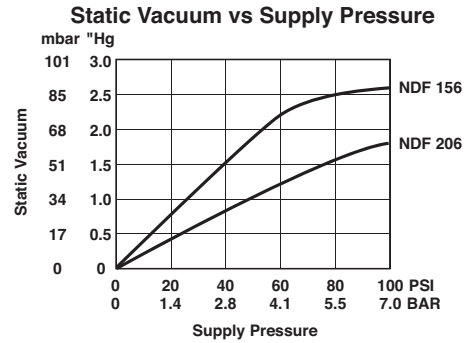
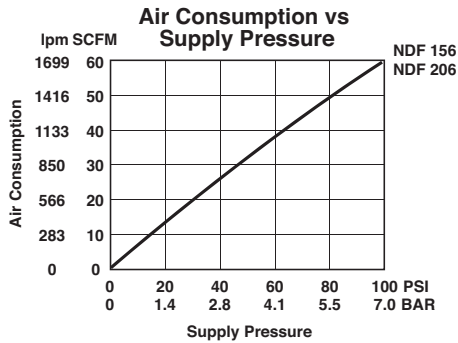

Operating Note: Above 40 PSI [2.7 bar], the increased energy consumed through rising air consumption is converted into increased vacuum level while vacuum flow stays constant. It is the vacuum flow that provides the motive force for the materials to be transferred. Higher vacuum levels are useful when lifting high molecular weight bulk materials and heavy individual objects long distances vertically.

Note: Performance Charts represent average performance data. For reference only.



Performance Data

NDF306, NDF4012

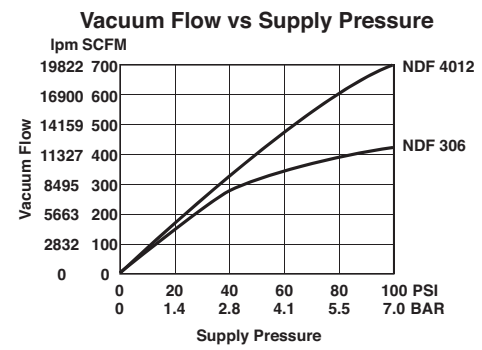
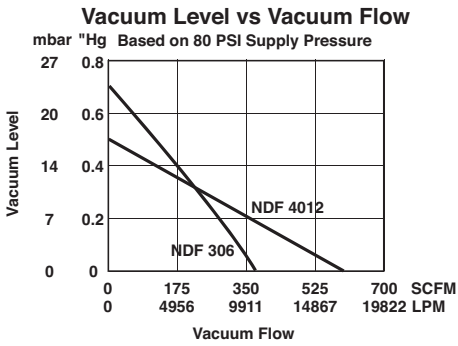
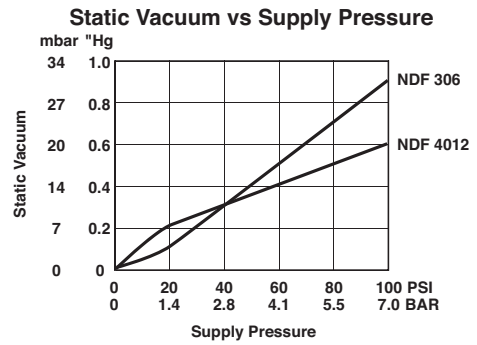
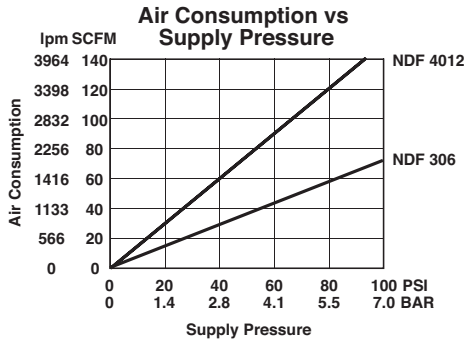

General Application Information

Sizing the correct NDF material transfer generator is based on the material density, particle size, transfer rate required (kg/min), elevation and length of transfer line.

For application assistance, please contact Norgren Technical Support. In many cases, customers send product to Norgren to test at our in-house test facility.

Transferring Bulk Materials:

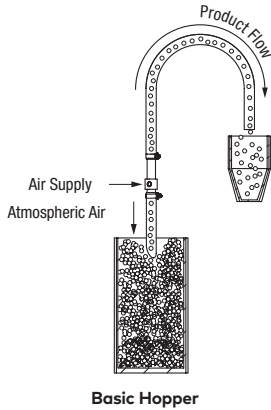

Place generator about 1/3 the overall distance from the suction. Allow the compressed air powering the generator to assist in pushing the material to the collection hopper.

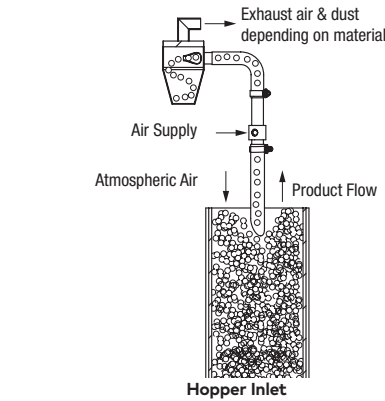

Induced atmospheric air, compressed air and the material being transferred enter the collection hopper, where the material falls by gravity. The air vents out the top of the hopper. To capture lighter-than-air materials, connect a filter or dust collector to the hopper outlet.

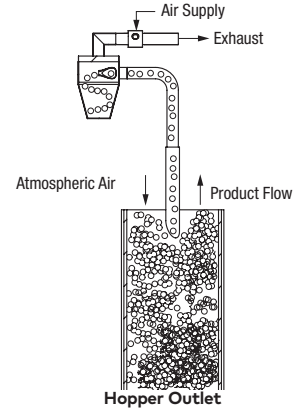

The NDF generator creates a vacuum in the collection hopper causing the material to flow up the conveyor tube into the collection hopper. Compressed air doesn't mix with the material, helping to prevent a cloud from forming when transferring fine, light powders. Material entering the hopper falls to the bottom faster due to the vacuum in the collection hopper. To reduce noise, add an optional silencer to the NDF generator exhaust.

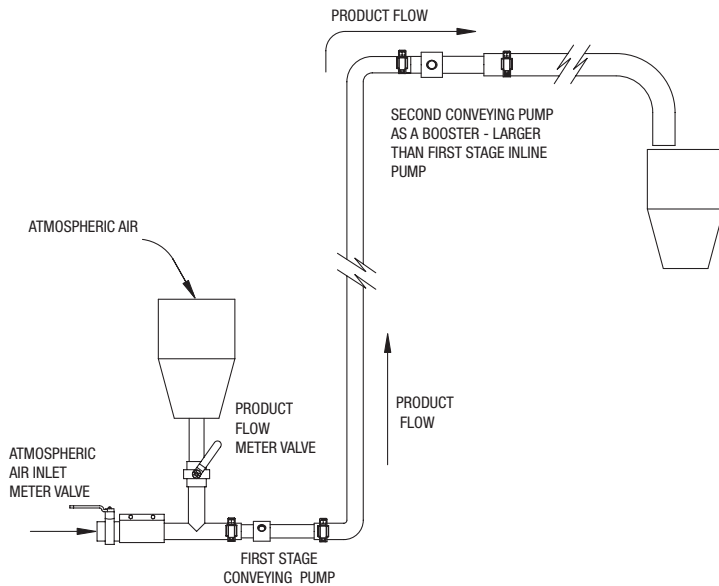

Transferring bulk and individual items vertically and horizontally over long distances may require a second conveying generator as a booster generator. To accept the flow generated by the first generator and to add power, add a booster generator that is larger than the first-stage generator. To maintain the proper balance between air intake and material intake use a valve to meter both.

Caution

When conveying materials through plastic transfer lines, you must ground the transfer line to dissipate the static charge that develops from the friction of the air and material flowing over the transfer line surface.



Transferring Bulk Materials:

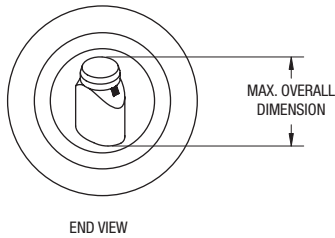

To size a NDF generator for transferring individual items, choose the generator with an inside diameter just slightly larger than the largest dimension of the object.

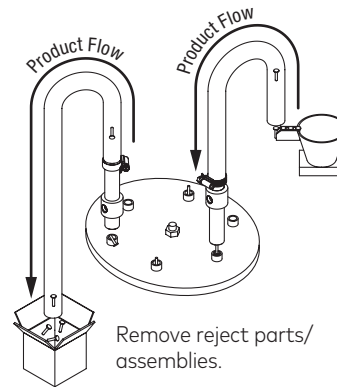

Load parts for assembly from a vibratory bowl feeder.

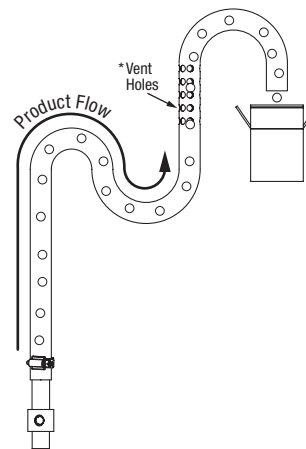
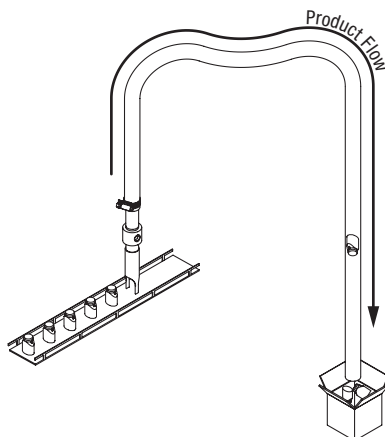

Design Tip: To prevent damage or to match the assembly speed, decrease the transfer speed by introducing a vertical bend into the tube, allowing gravity to work against the direction of travel.

* To reduce transfer speed further, add holes in the tube to allow the air to vent.

Caution: When conveying materials through plastic transfer lines, you must ground the transfer line to dissipate the static charge that develops from the friction of the air and material flowing over the transfer line surface.

Trim, Selvage and Fiber Collection:

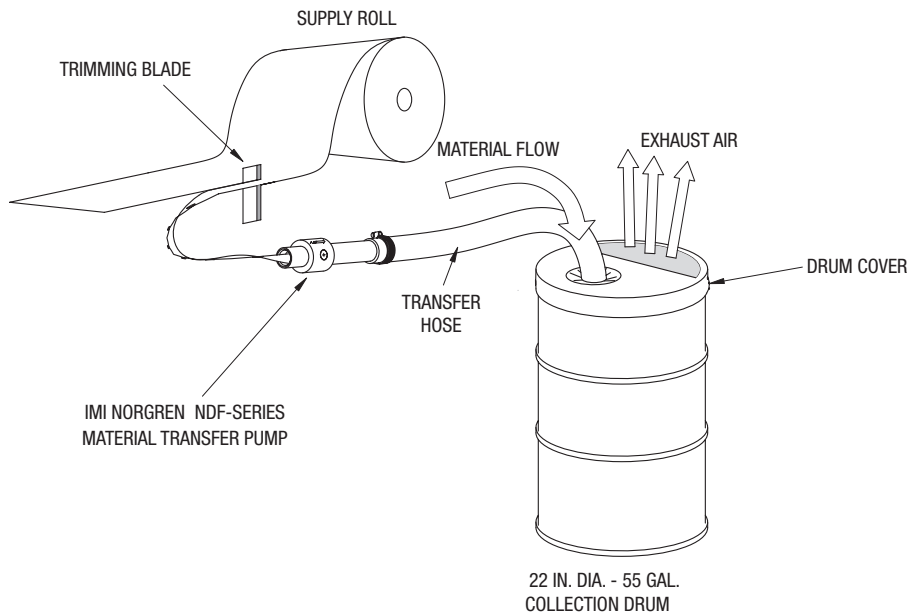

Installation Options

For simple applications, place the NDF generator in the transfer line, slip the transfer hose over the outside diameter of the generator and secure in place with a hose clamp. When this type of installation is not desired or appropriate for the application, Norgren offers the option of adding threads to the O.D. and the I.D.

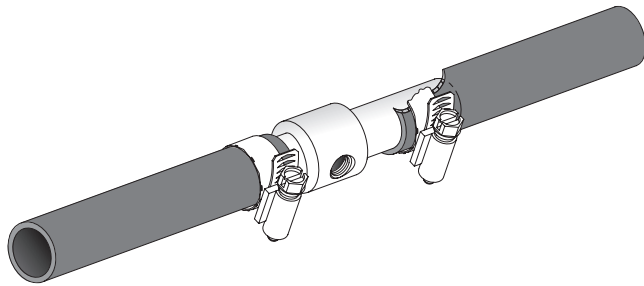

Warnings

Improper selection, misuse, age or malfunction of components used in systems can cause failure in various modes. The system designer is warned to consider the failure modes of all component parts and to provide adequate safeguards to prevent personal injury or damage to equipment or property in the event of such failure modes. System designers and end users are cautioned to consult instruction sheets and specifications available from the factory. The system designer/end user is responsible for verifying that all requirements for the application are met.

Warranty

The products described herein are warranted subject to seller's Standard Terms and Condition of Sale, available at seller's website.

[Vacuum Cups & Fittings]

Norgren offers an extensive line of vacuum cups and fittings to meet most every need. Our vacuum cups are available in a variety of materials, shapes and sizes.



Wide range of shapes and sizes



Materials to suit most applications

Please note: These products represent only part of the Norgren vacuum range. If you can't see the option you require please contact us.

Vacuum Cups & Fittings

<p>Food Handling Appl. Cups FDA compliant cup options available to better suit food handling applications.</p>  <p>Page 139</p>	<p>Packaging Appl. Cups Specially designed cups allowing for gentle package handling operations.</p>  <p>Page 141</p>	<p>Sheet Metal Appl. Cups Various cups available that were designed specifically to grip sheet metal.</p>  <p>Page 143</p>	<p>Electronic Cups Similar to the ultra miniature cups, designed to pick up small electronic components.</p>  <p>Page 148</p>	<p>Ultra Miniature Cups For extremely small parts such as computer and electronic components.</p>  <p>Page 149</p>	<p>General Purpose - Oval Cups Oval cups have heavy load capabilities due to their rigid design.</p>  <p>Page 150</p>
<p>General Purpose - Single Bellows Cups Allows the cup to conform to the work piece while accommodating variations in part presentation.</p>  <p>Page 154</p>	<p>General Purpose - Multi Bellows Cups Allows the cup to conform to the work piece, single and dual durometer options available.</p>  <p>Page 161</p>	<p>General Purpose - Flat Cups Allow for a firm grip on the work piece. Options available with and without cleats.</p>  <p>Page 165</p>	<p>Vacuum Fittings To connect cups and spring levelers to vacuum generators.</p>  <p>Page 176</p>	<p>Push-In-Fittings To connect all vacuum components.</p>  <p>Page 199</p>	

6 VACUUM CUPS



Wide range of shapes and sizes



Materials to suit most applications

Norgren offers a wide range of vacuum cup styles, materials, sizes and capabilities. Fittings in multiple styles are available individually or as a cup assembly for each cup group.

VACUUM CUPS



- » Wide range of sizes – 0.09" to 7.9" in diameter
- » Flat and bellows cups available to provide flexibility
- » Round and oval cups
- » Non-contact vacuum pads
- » Variety of materials available
 - Dual durometer for long wear and excellent sealing
 - FDA-approved material



Vacuum Cup Material Specifications

Cups are available in various durometers, colors and materials. If you do not see what you are looking for, please consult factory. Below is a general description of the various materials available and their characteristics.

Materials	Temperature Range	Wear Resistance	Oil Resistance	Series	Durometer	Application
Conductive NBR	+14°F to +213°F (-10°C to +100°C)	Excellent	Excellent	NBG, NCG, NFD, NFG, NFR, NSG, NUB, NUC, NUX, NUU	55	Dissipates static electricity to protect electronics with wide operating temperature ranges
Conductive NBR	+50°F to 212°F (-10°C to +100°C)	Good	Good	NVC-VI	-	Dissipates static electricity to protect electronics with wide operating temperature range
Conductive Silicone	-22°F to +392°F (-30°C to +200°C)	Fair	Fair	NBG, NCG, NSG	50	Dissipates static electricity to protect electronics with wide operating temperature range
Conductive Silicone	-22°F to +392°F (-30°C to +200°C)	Fair	Fair	NCF, NFD, NFG, NFR, NSB, NUB, NUC, NUU	55	Dissipates static electricity to protect electronics with wide operating temperature range
(High Temperature) Conductive Silicone	-4°F to +572°F (-20°C to +300°C)	Good	Good	NVC-VI	-	ESD
EPDM - Grey	-22°F to +302°F (-30°C to +150°C)	Good	Fair	NFG	50	Chemical Resistance
EPDM - Black	-22°F to +302°F (-30°C to +150°C)	Good	Fair	NBG, NCG, NFD, NUB, NUC, NUU	55	Chemical Resistance
Fluorine Rubber	+14°F to +662°F (-10°C to +350°C)	Excellent	Good	NBG, NFD, NFG, NFB, NHB, NUB, NUC, NUU	65	Excellent chemical resistance and high operating temperatures
High Temperature/Mark Free - Blue	+14°F to +356°F (-10°C to +180°C)	Excellent	Excellent	NFG, NFT	60	High temperature applications, non-marking
Mark Free NBR	-4°F to +230°F (-20°C to +110°C)	Excellent	Excellent	NUB, NUU, NBG, NFG	55	Excellent wear capabilities without marking work piece
NBR - Black	-4°F to +230°F (-20°C to +110°C)	Very Good	Very Good	NFD, NSB, NUB, NUC, NUU	50	General-purpose material with good oil and abrasions performance
NBR - Black	-4°F to +230°F (-20°C to +110°C)	Very Good	Very Good	NBG, NCF, NCG, NFG, NFB, NFR, NHB, NSF, NSG	55	General-purpose material with good oil and abrasions performance
NBR - Green	-4°F to +230°F (-20°C to +110°C)	Very Good	Very Good	NOF, NRF	45	General-purpose material with good oil and abrasions performance
NBR - Orange	-4°F to +230°F (-20°C to +110°C)	Very Good	Very Good	NOB, NOF, NRB, NRF	60	General-purpose material with good oil and abrasions performance
(Dual Durometer) Polyurethane - Light Blue/Yellow	+50°F to +122°F (+10°C to +50°C)	Excellent	Very Good	NSM	30-55	Longer bellow life, chemical resistance
(Dual Durometer) Polyurethane - Light Blue/Dark Blue	+50°F to +122°F (+10°C to +50°C)	Excellent	Very Good	NDB, NDM,, NSM	30-60	Longer bellow life, chemical resistance
Polyurethane - Blue	+50°F to +140°F (+10°C to +60°C)	Excellent	Very Good	NCG, NDB, NDM, NPF	60	Better wearing lip material
Polyurethane - Green	+32°F to +151°F (0°C to +66°C)	Excellent	Very Good	NCG, NDM, NSM, NVC	55	Better wearing lip material
Polyurethane - Light Blue	+50°F to +140°F (+10°C to +60°C)	Excellent	Very Good	NPF	70	Better wearing lip material, hard and ridged
Polyurethane - Yellow	+50°F to +140°F (+10°C to +60°C)	Excellent	Very Good	NCG, NDB, NPF	40	Better wearing lip material, soft and flexible
Silicone - Blue	-40°F to +482°F (-40°C to +250°C)	Fair	Fair	NWP	35	Good for high temperature performance and non-marking
(High Temperature) Silicone - White	-4°F to +572°F (-20°C to +300°C)	Good	Good	NVC-VI	-	Non-ESD
Silicone - Red	-40°F to +482°F (-40°C to +250°C)	Fair	Fair	NBLP, NCF	40	High temperature performance and non-marking



Vacuum Cup Selection Guide

Materials	Temperature Range	Wear Resistance	Oil Resistance	Series	Durometer	Application
Silicone - Red	-40°F to +482°F (-40°C to +250°C)	Fair	Fair	NCF, NSB, NSF	50	FDA compliant, high temperature performance and non-marking
Silicone - White	-40°F to +482°F (-40°C to +250°C)	Fair	Fair	PRF, NUB, NUC, NUU	45	High temperature performance and non-marking
Silicone - White	-40°F to +482°F (-40°C to +250°C)	Fair	Fair	NCF, NSB, NSF	50	High temperature performance and non-marking
Vinyl - Blue	+32°F to +125°F (0°C to +52°C)	Excellent	Fair	NVC-B, NVC-F, NVC-MB, NVCO	20-75	General-purpose material with excellent wear capabilities
Vinyl - Blue	+32°F to +125°F (0°C to +52°C)	Excellent	Fair	NOV	55	General-purpose material with excellent wear capabilities
(Oil Resistance) Vinyl	+32°F to +125°F (0°C to +52°C)	Good	Excellent	NVC-B, NVC-F, NVC-MB, NVCO	40-60	Excellent for oil resistance applications

Vacuum Cup Terms and Definitions:

- Bellows:** The fold or collapsible area that allows the cup to compress like an accordion
- Convolution:** The folded area of a bellows cup that makes up 1 external "V"
- Cleats:** Bottom protrusions used for maintaining a larger vacuum area
- Durometer:** Method by which the hardness of a material is gauged
- Insert/Fitting:** Metal piece bonded or inserted into the material to allow fastening by threads or bolts
- Vacuum cup:** Cup that requires the use of an external vacuum source to adhere to a surface
- Vacuum Level:** The magnitude of suction created by a vacuum generator typically measured in inches of mercury "Hg or [mbar]
- Vacuum Flow:** The volume of free air induced by the vacuum generator per unit of time, typically measured in SCFM (L/min)
- Porosity:** Ability of air to pass through a material

Standard Atmospheric Pressure Measured at Sea Level: 1 ATM = 14.7 PSI = 29.92"Hg = 760 mmHg = 1 bar

Facts to Remember:

- 50 mmHg = 1 PSI
- 1mmHg = 1 torr (vacuum)
- 1"Hg = 25.4 mmHg
- 2"Hg = 1 PSI
- 29.92"Hg = 100 Kpa
- 14.7 PSI = 100 Kpa
- 14.7 PSI = 29.92"Hg
- 14.7 PSI = 760 mmHg

Conversion Chart – Vacuum vs. Pressure				
% Vacuum	"Hg	mmHg	bar	PSI
10	3	76.92	-0.1	-1.47
20	6	153.85	-0.2	-2.94
30	9	230.77	-0.3	-4.41
40	12	307.69	-0.4	-5.88
50	15	384.62	-0.5	-7.35
60	18	461.54	-0.6	-8.82
70	21	538.46	-0.7	-10.29
80	24	615.38	-0.8	-11.76
90	27	692.31	-0.9	-13.23
100	30	769.23	-1.0	-14.70

Vacuum Cup Selection Guide

As is true in most vacuum applications, there is more than one correct answer.

In order to successfully find the best cup(s) and generators for a specific task, it is helpful to review the guidelines below.

Vacuum Cup Sizing

Choose the cup size, quantity, material and style based on the size of the object being handled, its weight, orientation, surface temperature, conditions and space available to mount the cups.

I. Determine the cup size by using the "Vacuum Cup Holding Force Calculation:"

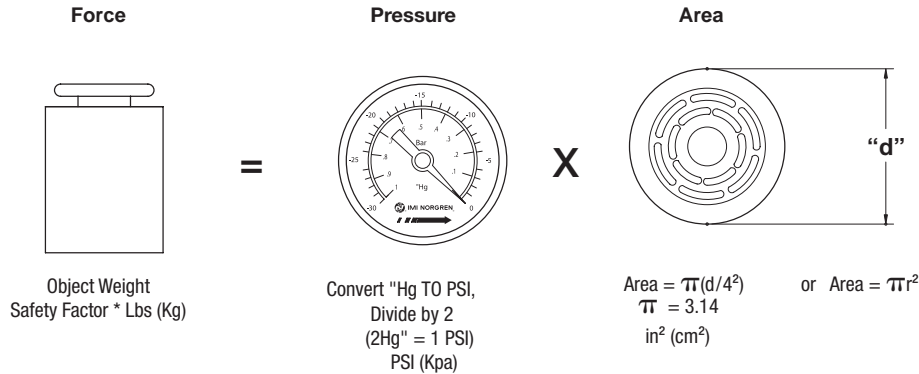

Force = Pressure x Area

F = the weight of the objects in lbs(kg) multiplied by the safety factor, see below.

P = the expected vacuum level in PSI (Kpa) (2Hg" = 1 PSI)

A = the area of the Vacuum cup measured by in² [cm²]

Safety Factors:

Always include safety factors when calculating lifting capabilities.

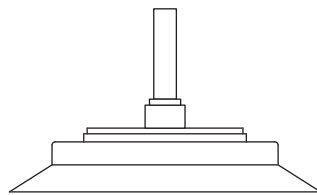

Safety Factor=2

Horizontal Lift = 2

Safety factor of 2 is recommended when cup face is in horizontal position.

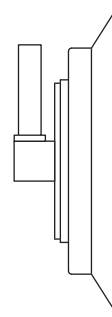

Safety Factor=4

Vertical Lift = 4

Safety factor of 4 is recommended when cup face is in a vertical position.



Vacuum Cup Selection Guide

II. Determine Type of Material to be handled: Non-Porous, Porous, Flexible/Non-Porous

Materials being handled in pick & place applications can be grouped into three categories – non-porous, porous and flexible. It is important to determine what type of material you are working with in order to determine the cup type, and the fitting choices. Norgren offers a variety of cup styles – including bellows, multi-bellows, round, oval, flat (with and without cleats), cups with removable fittings and cups with permanent fittings.

Non-Porous Materials: steel, glass, laminated chipboard, rigid plastic, semiconductors, etc.

Handling non-porous materials is the easiest application for choosing a vacuum cup and vacuum generator because there is no vacuum flow (leakage). The cup seals to the surface of the object enabling the generator to reach its maximum vacuum level.

Typically, flat cleated cups are used for non-porous applications because the rigid, low profile design resists peeling away. In horizontal applications, where there is a large array of cups, bellows cups may be an option as they offer the pliability needed to ensure that all cups make contact with the object(s) being handled.

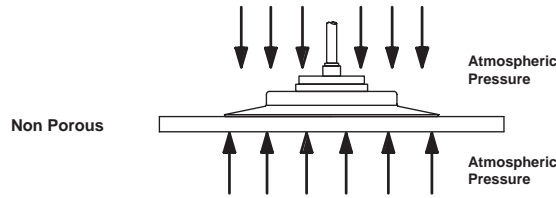

Example: Holding Force Calculation for Non-Porous Materials

Application: lift a 100 lb [45.36 kg] steel plate, 1/8" [3mm] thick, measuring 4' x 4' [121.9cm X 121.9cm] from a horizontal stack and place into a press. Norgren recommends an "H" series generator when handling non-porous materials. All "H" series generators generate 14 PSI [28"Hg, 0.965 bar].

$$F = P * A$$

Force = 200 lbs [90.72 kg] (weight x safety factor/horizontal lift or 100 lbs [45.36 kg] x 2)
 Pressure = 14 PSI [.965 bar] (convert 28"Hg to PSI by dividing by 2)

If F (200 lbs [90.72 kg]) = P (14 PSI [.965 bar]) * A (Solve for A)

$A = 200/14$ [90.72/.965] which is 14.3 in² [94.01 cm²] – " A " represents the total area of the cup or all the cups combined to lift this load horizontally

Determine the Number of Cups Needed to Determine the Diameter of each Cup

Whereas the metal is only 1/8" [3mm] thick, it will tend to droop. Norgren recommends using 2 rows of 3 cups each for a total of 6 cups. Therefore, 14.3 in² [94.01 cm²] divided by 6 cups = 2.38 in² [15.67 cm²] is the area per cup

Solve for the diameter (d) using the equation: $A = \pi * [d^2 / 4]$ or πr^2	$[A = \pi * (d^2 / 4)]$ or πr^2
$d^2 = 4 * 2.38 / \pi$ or $d^2 = 3.03$ in ²	$[d^2 = 4 * 15.67 / \pi]$ or $d^2 = 19.96$ cm ²
$d = \text{sq. root of } 3.03$ or 1.74 in	$[d = \text{sq. root of } 19.96]$ or 44.7mm

Solution: Choose a flat cup with cleats with a diameter of 1.75" [44.45mm] or greater. With plenty of space on the steel plate to position cups, choosing a larger cup will add to the holding force and take into account any acceleration or deceleration loads during transfer.

Vacuum Cup Selection Guide

Porous Materials: corrugated, woven materials, or objects with extremely rough or uneven surfaces

When handling porous materials, it is important that the flow path between the object and the vacuum generator is as large as necessary to allow the generator to draw away the air that leaks through the surface or from gaps between the cup and the surface. Pay close attention to the bore size of the fitting in the cup, as well as the size of the vacuum lines. To confirm vacuum lines are sized properly, see the Operating and Installation Instructions section for each generator.

When calculating the holding force for porous materials, the vacuum level that will be achieved is not normally known because the leak rate of the material is unknown. To move forward and determine the diameter of the vacuum cups, assume that system will reach a vacuum level of 8 PSI [16"Hg, 0.542 bar].

Norgren recommends the "M" series vacuum generators to maximize flow and minimize compressed air usage when handling porous materials. To ensure that the vacuum level of 8 PSI [16"Hg, .542 bar] is achieved, contact Norgren Tech Support for a generator recommendation.

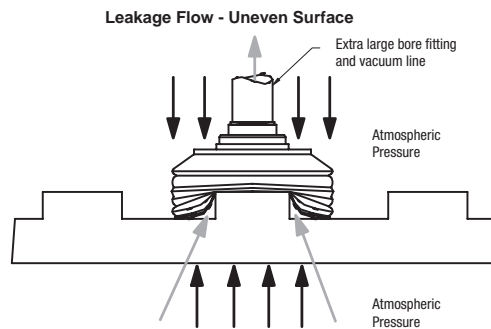
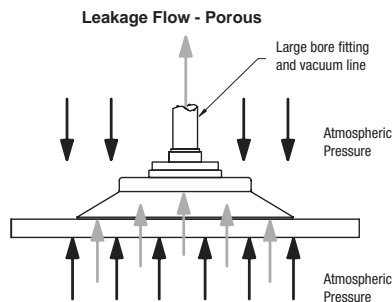

Example: Holding Force Calculation for Porous Materials or Uneven Surfaces

Application: lift a 100 lb [45.36 kg] corrugated box with vacuum cups in the horizontal plane. Remember the safety factor and the equation $F = P * A$.

200 lbs [90.72 kg] = 8 PSI [.542 bar] x **A** - Solve for **A** - the total vacuum cup(s) area.

$A = 200 [90.72] / 8 [.542 \text{ bar}] = 25 \text{ in}^2 [164.35 \text{ cm}^2]$ of combined cup area. Assume the number of cups used will be 4.

Determine the Number of Cups Needed to Determine the Diameter of each Cup

Divide the total area by the number of cups $(25/4)[164.35/4]$ - area of each cup is $6.25 \text{ in}^2 [41.09 \text{ cm}^2]$.

Solve for the diameter (d^2) using the equation: $A = \pi * d^2/4$, $6.25 = 3.14 (d^2)/4$ $[A = \pi * d^2/4, 41.09 = 3.14 (d^2/4)]$
 $d = \text{square root of } (6.25 * 4/3.14) = 2.82$ $[d = \text{square root of } (41.09 * 4/3.14) = 72.3 \text{ mm}]$

Solution: Choose a flat cup with cleats or bellows cups with a diameter of 3" [76.2mm] or greater. (Dimensions have been rounded up.) In this situation, Norgren recommends a NVP80-250M vacuum generator.



Vacuum Cup Selection Guide

Flexible Materials: plastic films, baked goods, IV bags, paper bags – things that wrinkle

When handling flexible packaging materials, it is critical that the cup fitting and the vacuum line have a very large bore. Flexible materials wrinkle, causing large leak paths. The cup and the vacuum generator must be sized to accommodate that leak rate. The bore of the fitting must be close to a 1:2 ratio to the diameter of the cup.

Typically, handling flexible materials does not involve heavy weights. Calculating cup holding force is not required. Choose a cup with a very thin flexible lip to ensure the cup conforms to the wrinkled material. Multi-bellows cups work well in these applications because of their flexibility.

The interaction between the vacuum cup and the flexible material is critical. Because the leakage flow rates are so high, it is necessary to use our NCDF Series of high flow (air amplifier) vacuum generators. With so many variables affecting performance, Norgren strongly suggests that a sample of the material be sent to our in-house test facility for a generator and cup recommendation.

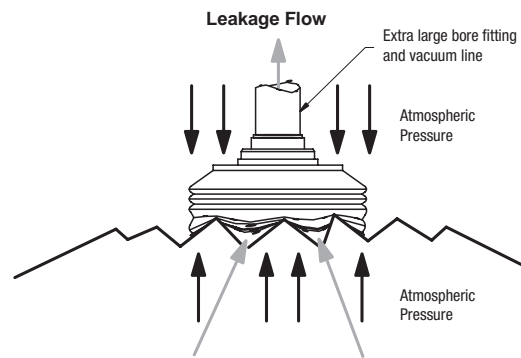

Specialty Cups – Food Handling

» The NBLP Series of vacuum cups provide a soft compliant cup with a thin lip. This soft, long multi-bellow cup has extreme flexibility allowing it to conform to a wide variety of parts and shapes making this cup an ideal fit for specialty applications in food handling processes. An optional insert can be added to prevent any flexible materials from being sucked too far inside the cup.



Specialty Cups - Food Handling: NBLP Style

Part Number		A - O.D. in. (mm)	Approx. Area sq. in. (sq. mm)	B - Height in. (mm)	B' - Collapsed Height in. (mm)	C in. (mm)	D - Thru Hole in. (mm)	Cleats	Standard Material	Optional Material	Weight oz (g)	Fitting Group
NBLP30XXXX		1.18 (30.0)	1.10 (707.0)	1.44 (36.5)	0.83 (21.1)	0.52 (13.2)	0.35 (9.0)	Yes	SI40	-	0.4 oz (10.2g)	14
NBLP30XXXXLD		1.18 (30.0)	1.10 (707.0)	1.44 (36.5)	0.83 (21.1)	0.52 (13.2)	0.35 (9.0)	Yes	SI40	-	0.4 oz (11.2g)	14
NBLP30XXXXSD		1.18 (30.0)	1.10 (707.0)	1.44 (36.5)	0.83 (21.1)	0.52 (13.2)	0.35 (9.0)	Yes	SI40	-	0.4 oz (11.2g)	14
NBLP40XXXX		1.57 (40.0)	1.95 (1257.0)	1.57 (40.0)	0.91 (23.2)	1.02 (26.0)	0.47 (12.0)	Yes	SI40	-	0.4 oz (12.4g)	16
NBLP40XXXXLD		1.57 (40.0)	1.95 (1257.0)	1.57 (40.0)	0.91 (23.2)	1.02 (26.0)	0.47 (12.0)	Yes	SI40	-	0.5 oz (13.4g)	16
NBLP40XXXXSD		1.57 (40.0)	1.95 (1257.0)	1.57 (40.0)	0.91 (23.2)	1.02 (26.0)	0.47 (12.0)	Yes	SI40	-	0.5 oz (13.4g)	16
NBLP50XXXX		1.97 (50.0)	3.04 (1963.0)	2.17 (55.0)	0.98 (25.0)	1.57 (40.0)	0.67 (17.0)	Yes	SI40	-	1.0 oz (29.0g)	17
NBLP50XXXXLD		1.97 (50.0)	3.04 (1963.0)	2.17 (55.0)	0.98 (25.0)	1.57 (40.0)	0.67 (17.0)	Yes	SI40	-	1.1 oz (30.0g)	17
NBLP50XXXXSD		1.97 (50.0)	3.04 (1963.0)	2.17 (55.0)	0.98 (25.0)	1.57 (40.0)	0.67 (17.0)	Yes	SI40	-	1.1 oz (30.0g)	17

* How to Order: All part numbers with an "XXXX" requires the customer to specify a material type to complete part number. I.E. NBLP30SI40SD (for Silicone material). See Chart below for material specifications.

Fittings: To order fittings, please reference the fitting groups section for the appropriate part numbers. NF indicates no fitting is required.

The weight of the cups shown is without fittings unless the fitting is standard ie: 1/4 NPTF. For fitting weights, see vacuum fitting section.

Optional inserts:

SD - rigid plastic insert to improve performance with flexible packaging material

LD - ridged plastic insert to improve performance with semi ridged packaging

Material	Color	Temperature Range
SI40 - Silicone	Red	-40°F to +482°F (-40°C to +250°C)

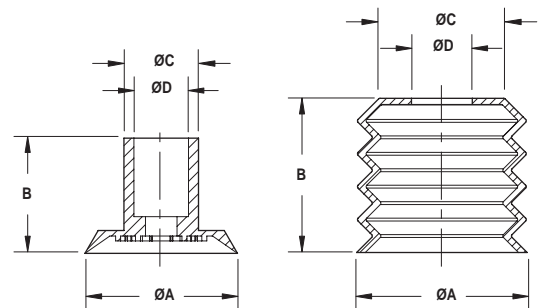



- » The NFD Series of vacuum cups are part of our universal cup series that uses a common fitting system. The deep cup allows the cup to conform to spherical objects used in various types of applications. The white silicone cup is ideal for use in food applications.



Specialty Cups - Food Handling: NFD Style

Part Number		A - O.D. in. (mm)	Approx. Area sq. in. (sq. mm)	B - Height in. (mm)	B ¹ - Collapsed Height in. (mm)	C in. (mm)	D - Thru Hole in. (mm)	Cleats	Standard Material	Optional Material	Weight oz (g)	Fitting Group
NFD010NB50		0.47 (12.0)	0.18 (113.0)	0.59 (10.0)	0.17 (4.3)	0.51 (13.0)	0.16 (4.0)	No	NB50, WS45	CN55, CS55, FL65, EP55	0.0 oz (0.9g)	2
NFD016XXXX		0.71 (18.0)	0.39 (254.0)	0.63 (16.0)	0.17 (4.3)	0.51 (13.0)	0.16 (4.0)	No	NB50, WS45	CN55, CS55, FL65, EP55	0.0 oz (1.3g)	2
NFD025XXXX		1.10 (28.0)	0.95 (616.0)	0.79 (20.0)	0.18 (4.5)	0.59 (15.0)	0.16 (4.0)	No	NB50, WS45	CN55, CS55, FL65, EP55	0.1 oz (2.5g)	7
NFD040XXXX		1.61 (41.0)	2.05 (1320.0)	1.10 (28.0)	0.18 (4.5)	0.71 (18.0)	0.28 (7.0)	No	NB50, WS45	CN55, CS55, FL65, EP55	0.2 oz (6.7g)	19

* How to Order: All part numbers ending with an "XXXX" requires the customer to specify a material type to complete part number. I.E. NFD040WS45 (for Silicone material). See Chart below for material specifications.

Fittings: To order fittings, please reference the fitting groups section for the appropriate part numbers. NF indicates no fitting is required. The weight of the cups shown is without fittings unless the fitting is standard ie: 1/4 NPTF. For fitting weights, see vacuum fitting section.

Material	Color	Temperature Range
NB50 - NBR	Black	-4°F to +230°F (-20°C to +110°C)
WS45 - Silicone	White	-40°F to +482°F (-40°C to +250°C)
CN55 - Conductive NBR	Black	-14°F to +212°F (-10°C to +100°C)
CS55 - Conductive Silicone	Black	-22°F to +392°F (-30°C to +200°C)
FL65 - Fluorine Rubber	Black	-14°F to +662°F (-10°C to +350°C)
EP55 - EPDM	Grey	-22°F to +302°F (-30°C to +150°C)

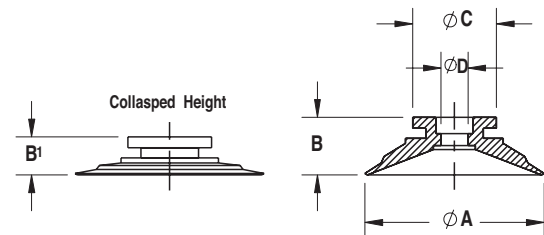

SPECIALTY CUPS – PACKAGING



» The NWP Series possesses a thin, wavy lip that is ideal for packaging applications. This thin wavy lip accomodates for wrinkles in plastic packaging. The silicone cup offers a wide operating temperature and has a unique fitting design preventing thin material from blocking the vacuum flow.



Specialty Cups – Packaging: NWP Style

Part Number		A - O.D. in. (mm)	Approx. Area sq. in. (sq. mm)	B - Height in. (mm)	B ¹ - Collapsed Height in. (mm)	C in. (mm)	D - Thru Hole in. (mm)	Cleats	Standard Material	Optional Material	Weight oz (g)	Fitting Group
NWP060BS35		2.42 (61.5)	4.38 (2827.4)	0.98 (24.8)	0.67 (15.2)	1.64 (41.6)	0.28 (7.0)	Yes	BS35	-	0.4 oz (11.0g)	30*
NWP060BS35G38F		2.42 (61.5)	4.38 (2827.4)	1.26 (32.0)	0.88 (22.4)	1.64 (41.6)	0.28 (7.0)	Yes	BS35	-	1.1 oz (32.0g)	G 3/8 F

Fittings: To order fittings, please reference the fitting groups section for the appropriate part numbers. NF indicates no fitting is required. The weight of the cups shown is without fittings unless the fitting is standard ie: 1/4 NPTF. For fitting weights, see vacuum fitting section.

*For fitting group 30, please contact our customer service team at 1-800-272-4511 or email NASInsideSales@imi-precision.com

Material	Color	Temperature Range
BS35 - Silicone	Blue	40°F to +482°F (-40°C to +250°C)

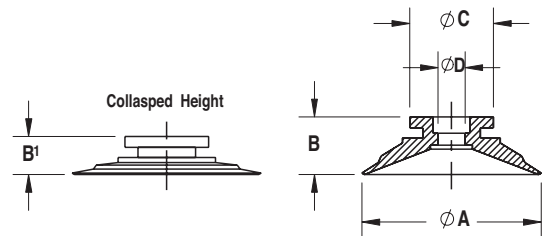



» The NFT Series is designed specifically for handling packaging. The thin lip of these cups allows for gently grabbing flexible materials without creating leaks.



Specialty Cups – Packaging: NFT Style

Part Number		A - O.D. in. (mm)	Approx. Area sq. in. (sq. mm)	B - Height in. (mm)	B ¹ - Collapsed Height in. (mm)	C in. (mm)	D - Thru Hole in. (mm)	Cleats	Standard Material	Optional Material	Weight oz (g)	Fitting Group
NFT015XXXX		0.57 (14.5)	0.26 (165.0)	0.39 (10.0)	0.36 (9.1)	0.35 (9.0)	0.14 (3.5)	Yes	WS50, HD60	-	0.0 oz (0.6g)	3
NFT020XXXX		0.82 (20.9)	0.53 (343.0)	0.41 (10.4)	0.35 (8.9)	0.41 (10.5)	0.14 (3.5)	Yes	WS50, HD60	-	0.0 oz (0.8g)	3
NFT024XXXX		0.96 (24.4)	0.72 (468.0)	0.43 (10.8)	0.36 (9.1)	0.39 (10.0)	0.14 (3.5)	Yes	WS50, HD60	-	0.0 oz (0.9g)	3
NFT030XXXX		1.20 (30.6)	1.14 (735.0)	0.86 (21.8)	0.75 (19.1)	0.61 (15.6)	0.26 (6.6)	Yes	WS50, HD60	-	0.1 oz (2.9g)	3
NFT034XXXX		1.36 (34.5)	1.45 (935.0)	0.91 (23.0)	0.85 (21.6)	0.58 (14.8)	0.23 (5.8)	Yes	WS50, HD60	-	0.1 oz (3.5g)	3

* How to Order: All part numbers ending with an "XXXX" requires the customer to specify a material type to complete part number. I.E. NFT020HD60 (for High Temp./Mark-Free material). See Chart below for material specifications.

Fittings: To order fittings, please reference the fitting groups section for the appropriate part numbers. NF indicates no fitting is required.

The weight of the cups shown is without fittings unless the fitting is standard ie: 1/4 NPTF. For fitting weights, see vacuum fitting section.

Material	Color	Temperature Range
WS50 - Silicone	White	-40°F to +482°F (-40°C to +250°C)
HD60 - High Temp./Mark Free	Blue	+14°F to +356°F (-10°C to +180°C)

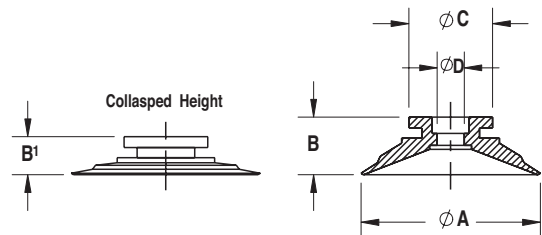

SPECIALTY CUPS – SHEET METAL



» The PRF Series of round flat cups offer a unique cleat profile for gripping sheet metal. The cleat profile prevents the cup from slipping on the work piece while providing a firm grip. The use of hard polyurethane material makes the cup resistant to abrasion and wear.



Specialty Cups – Sheet Metal: PRF Style

Part Number		A - O.D. in. (mm)	Approx. Area sq. in. (sq. mm)	B - Height in. (mm)	B ¹ - Collapsed Height in. (mm)	C in. (mm)	D - Thru Hole in. (mm)	Cleats	Standard Material	Optional Material	Weight oz (g)	Fitting Group
PRF030XXXG38F		1.34 (34.0)	1.37 (881.0)	1.36 (34.5)	1.20 (30.5)	0.73 (18.5)	0.28 (7.0)	Yes	PU70	-	0.1 oz (4.1g)	G 3/8 F
PRF030XXXN38F		1.34 (34.0)	1.37 (881.0)	1.36 (34.5)	1.20 (30.5)	0.73 (18.5)	0.20 (5.0)	Yes	PU70	-	0.1 oz (4.1g)	3/8 NPT F
PRF050XXXG38F		2.17 (55.0)	3.56 (2290.0)	1.65 (42.0)	1.35 (34.2)	0.87 (22.0)	0.28 (7.0)	Yes	PU70	-	0.4 oz (10.2g)	G 3/8 F
PRF050XXXN38F		2.17 (55.0)	3.56 (2290.0)	1.65 (42.0)	1.35 (34.2)	0.87 (22.0)	0.20 (5.0)	Yes	PU70	-	0.4 oz (10.2g)	G 3/8 F
PRF080XXXG38F		3.35 (85.0)	8.81 (5675.0)	1.85 (47.0)	1.34 (34.0)	0.71 (18.0)	0.28 (7.0)	Yes	PU70	-	0.9 oz (25.2g)	G 3/8 F
PRF080XXXN38F		3.35 (85.0)	8.81 (5675.0)	1.85 (47.0)	1.34 (34.0)	0.71 (18.0)	0.20 (5.0)	Yes	PU70	-	0.9 oz (25.2g)	3/8 NPT F
PRF100XXXG38F		4.15 (105.5)	12.95 (8332.0)	2.13 (54.0)	1.52 (38.5)	0.71 (18.0)	0.28 (7.0)	Yes	PU70	-	1.5 oz (42.0g)	G 3/8 F
PRF100XXXN38F		4.15 (105.5)	12.95 (8332.0)	2.13 (54.0)	1.52 (38.5)	0.71 (18.0)	0.20 (5.0)	Yes	PU70	-	1.5 oz (42.0g)	3/8 NPT F

* How to Order: All part numbers with an "XXXX" requires the customer to specify a material type to complete part number. I.E. PRF030PU70G38F (for Polyurethane material). See Chart below for material specifications.
 Fittings: To order fittings, please reference the fitting groups section for the appropriate part numbers. NF indicates no fitting is required.
 The weight of the cups shown is without fittings unless the fitting is standard ie: 1/4 NPTF. For fitting weights, see vacuum fitting section.

Material	Color	Temperature Range
PU70 - Polyurethane	Light Blue	-50°F to +140°F (10°C to +60°C)

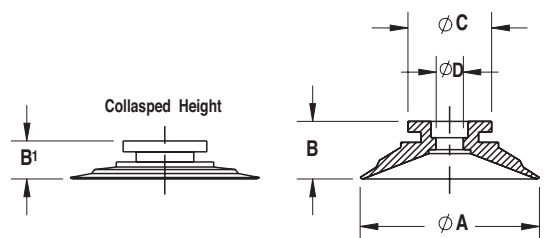



» The NOB Series of oval bellow cups offer a unique profile for gripping sheet metal. The cleat profile prevents the cup from slipping on the work piece while providing a firm grip. The use of 60 durometer NBR material makes the cup resistant to abrasion and wear. These cups are ideal for applications with curved surfaces, glass, oily materials, and automotive industries.



Specialty Cups – Sheet Metal: NOB Style

Part Number		A - O.D. in. (mm)	Approx. Area sq. in. (sq. mm)	B - Height in. (mm)	B' - Collapsed Height in. (mm)	C in. (mm)	D - Thru Hole in. (mm)	Cleats	Standard Material	Optional Material	Weight oz (g)	Fitting Group
NOB030X060XXXXG38F		1.31x2.44 (32.0x62.0)	2.24 (1444.0)	1.34 (34.0)	1.10 (28.0)	-	0.20 (5.0)	Yes	NB60	-	1.1 oz (31.2g)	G 3/8 F
NOB030X060XXXXN38F		1.31x2.44 (32.0x62.0)	2.24 (1444.0)	1.34 (34.0)	1.10 (28.0)	-	0.20 (5.0)	Yes	NB60	-	1.1 oz (31.2g)	3/8 NPT F
NOB040X080XXXXG38F		16.5x3.23 (42.0x82.0)	4.75 (3065.0)	1.46 (37.0)	1.11 (28.2)	-	0.20 (5.0)	Yes	NB60	-	1.4 oz (39.6g)	G 3/8 F
NOB040X080XXXXN38F		16.5x3.23 (42.0x82.0)	4.75 (3065.0)	1.46 (37.0)	1.11 (28.2)	-	0.20 (5.0)	Yes	NB60	-	1.4 oz (39.6g)	3/8 NPT F
NOB070X140XXXXG38F		2.83x5.63 (72.0x143.0)	13.90 (8968.0)	1.87 (47.5)	1.20 (30.5)	-	0.20 (5.0)	Yes	NB60	-	5.0 oz (140.4g)	G 3/8 F
NOB070X140XXXXN38F		2.83x5.63 (72.0x143.0)	13.90 (8968.0)	1.87 (47.5)	1.20 (30.5)	-	0.20 (5.0)	Yes	NB60	-	5.0 oz (140.4g)	3/8 NPT F

* How to Order: All part numbers with an "XXXX" requires the customer to specify a material type to complete part number.

I.E. NOB030X060NB60G38F (for NBR material). See Chart below for material specifications.

Fittings: To order fittings, please reference the fitting groups section for the appropriate part numbers. NF indicates no fitting is required.

The weight of the cups shown is without fittings unless the fitting is standard ie: 1/4 NPTF. For fitting weights, see vacuum fitting section.

Material	Color	Temperature Range
NB60 - NBR	Orange	-4°F to +230°F (-20°C to +110°C)

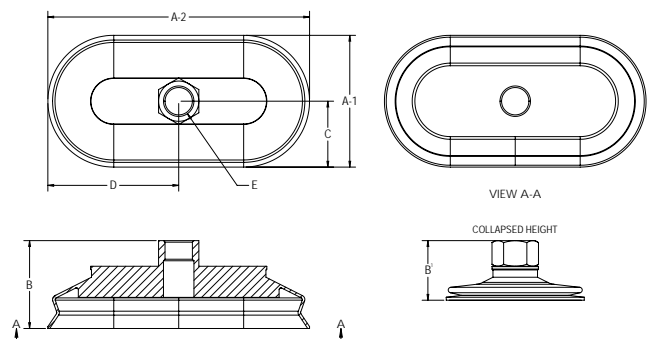

SPECIALTY CUPS – SHEET METAL



» The NOF Series of oval flat cups offer a unique cleat profile for gripping sheet metal. The cleat profile prevents the cup from slipping on the work piece while providing a firm grip. The use of NBR material makes the cup resistant to abrasion and wear making the cups ideal for applications with curved surfaces, glass, oily materials, and objects in automotive industry.



Specialty Cups – Sheet Metal: NOF Style

Part Number		A - O.D. in. (mm)	Approx. Area sq. in. (sq. mm)	B - Height in. (mm)	B ¹ - Collapsed Height in. (mm)	C in. (mm)	D - Thru Hole in. (mm)	Cleats	Standard Material	Optional Material	Weight oz (g)	Fitting Group
NOF023X060XXXG38F		0.98x2.44 (25.0x62.0)	2.19 (1416.0)	1.02 (26.0)	0.91 (23.0)	- (-)	0.20 (5.0)	Yes	NB60	NB45	1.0 oz (29.0g)	G 3/8 F
NOF023X060XXXN38F		0.98x2.44 (25.0x62.0)	2.19 (1416.0)	1.02 (26.0)	0.91 (23.0)	- (-)	0.20 (5.0)	Yes	NB60	NB45	1.0 oz (29.0g)	3/8 NPT F
NOF050X100XXXG38F		2.13x5.63 (54.0x103.0)	7.65 (4936.0)	1.18 (30.0)	1.00 (25.3)	- (-)	0.20 (5.0)	Yes	NB60	NB45	2.0 oz (56.0g)	G 3/8 F
NOF050X100XXXN38F		2.13x5.63 (54.0x103.0)	7.65 (4936.0)	1.18 (30.0)	1.00 (25.3)	- (-)	0.20 (5.0)	Yes	NB60	NB45	2.0 oz (56.0g)	3/8 NPT F
NOF070X140XXXG38F		2.99x5.63 (76.0x143.0)	14.92 (9628.0)	1.30 (33.0)	1.06 (27.0)	- (-)	0.20 (5.0)	Yes	NB60	NB45	2.7 oz (77.0g)	G 3/8 F
NOF070X140XXXN38F		2.99x5.63 (76.0x143.0)	14.92 (9628.0)	1.30 (33.0)	1.06 (27.0)	- (-)	0.20 (5.0)	Yes	NB60	NB45	2.0 oz (56.0g)	3/8 NPT F

* How to Order: All part numbers with an "XXXX" requires the customer to specify a material type to complete part number. I.E. NOF050X100NB60N38F (for NBR material). See Chart below for material specifications.
 Fittings: To order fittings, please reference the fitting groups section for the appropriate part numbers. NF indicates no fitting is required.
 The weight of the cups shown is without fittings unless the fitting is standard ie: 1/4 NPTF. For fitting weights, see vacuum fitting section.

Material	Color	Temperature Range
NB60 - NBR	Orange	-4°F to +230°F (-20°C to +110°C)

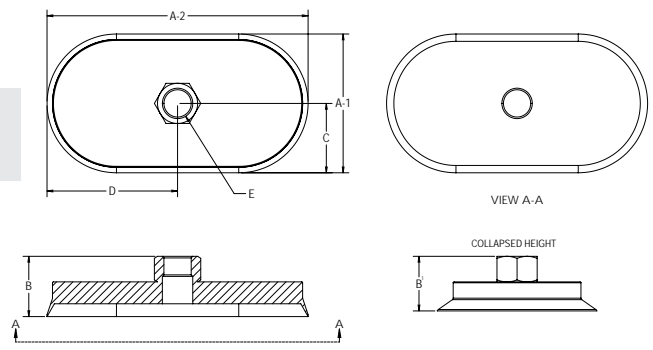



» The NRB Series of round bellow cups offer a unique cleat profile that prevents the cup from slipping on the work piece while still providing a firm grip. The use of 60 durometer NBR material makes the cup resistant to abrasion and wear.



Specialty Cups – Sheet Metal: NRB Style

Part Number		A - O.D. in. (mm)	Approx. Area sq. in. (sq. mm)	B - Height in. (mm)	B' - Collapsed Height in. (mm)	C in. (mm)	D - Thru Hole in. (mm)	Cleats	Standard Material	Optional Material	Weight oz (g)	Fitting Group
NRB030XXXXG38F		1.26 (32.0)	1.25 (804.0)	1.65 (42.0)	1.28 (32.5)	1.02 (25.8)	0.16 (4.0)	Yes	NB60	-	0.05 oz (14.4g)	G 3/8 F
NRB030XXXXN38F		1.26 (32.0)	1.25 (804.0)	1.65 (42.0)	1.28 (32.5)	1.02 (25.8)	0.16 (4.0)	Yes	NB60	-	0.05 oz (14.4g)	3/8 NPT F
NRB050XXXXG38F		2.05 (52.0)	3.30 (2124.0)	1.42 (36.0)	0.96 (24.5)	1.46 (37.0)	0.24 (6.0)	Yes	NB60	-	0.9 oz (25.2g)	G 3/8 F
NRB050XXXXN38F		2.05 (52.0)	3.30 (2124.0)	1.42 (36.0)	0.96 (24.5)	1.46 (37.0)	0.24 (6.0)	Yes	NB60	-	0.9 oz (25.2g)	3/8 NPT F
NRB080XXXXG38F		3.25 (82.0)	8.19 (5281.0)	1.95 (49.5)	1.06 (27.0)	1.57 (40.0)	0.24 (6.00)	Yes	NB60	-	2.2 oz (61.2g)	G 3/8 F
NRB080XXXXN38F		3.25 (82.0)	8.19 (5281.0)	1.95 (49.5)	1.06 (27.0)	1.57 (40.0)	0.24 (6.0)	Yes	NB60	-	2.2 oz (61.2g)	3/8 NPT F
NRB100XXXXG38F		4.06 (103.0)	12.79 (8252.0)	2.17 (55.0)	1.18 (30.0)	1.57 (40.0)	0.24 (6.0)	Yes	NB60	-	3.3 oz (92.4g)	G 3/8 F
NRB100XXXXN38F		4.06 (103.0)	12.79 (8252.0)	2.17 (55.0)	1.18 (30.0)	1.57 (40.0)	0.24 (6.0)	Yes	NB60	-	3.3 oz (92.4g)	3/8 NPT F

* How to Order: All part numbers with an "XXXX" requires the customer to specify a material type to complete part number. I.E. NRB030NB60N38F (for NBR material). See Chart below for material specifications.

Fittings: To order fittings, please reference the fitting groups section for the appropriate part numbers. NF indicates no fitting is required.

The weight of the cups shown is without fittings unless the fitting is standard ie: 1/4 NPTF. For fitting weights, see vacuum fitting section.

Material	Color	Temperature Range
NB60 - NBR	Orange	-4°F to +230°F (-20°C to +110°C)

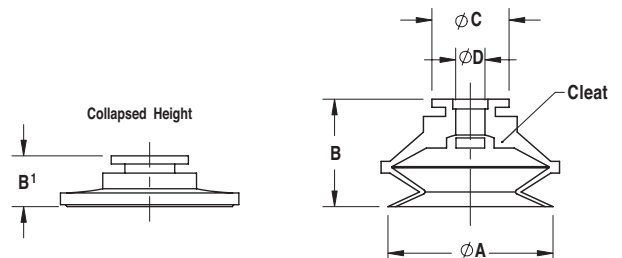

SPECIALTY CUPS – SHEET METAL



» The NRF Series of round flat cups offer a unique cleat profile for gripping sheet metal. The cleat profile prevents the cup from slipping on the work piece while providing a firm grip. The use of NBR material makes the cup resistant to abrasion and wear.



Specialty Cups: NRF Style

Part Number		A - O.D. in. (mm)	Approx. Area sq. in. (sq. mm)	B - Height in. (mm)	B ¹ - Collapsed Height in. (mm)	C in. (mm)	D - Thru Hole in. (mm)	Cleats	Standard Material	Optional Material	Weight oz (g)	Fitting Group
NRF030XXXG38F		1.26 (32.0)	1.25 (804.0)	1.32 (33.5)	1.21 (30.8)	1.02 (25.8)	0.16 (4.0)	Yes	NB60	NB45	0.05 oz (13.2g)	G 3/8 F
NRF030XXXN38F		1.26 (32.0)	1.25 (804.0)	1.32 (33.5)	1.21 (30.8)	1.02 (25.8)	0.16 (4.0)	Yes	NB60	NB45	0.05 oz (13.2g)	3/8 NPT F
NRF050XXXG38F		2.05 (52.0)	3.30 (2124.0)	1.10 (28.0)	0.92 (23.3)	1.46 (37.0)	0.24 (6.0)	Yes	NB60	NB45	0.8 oz (24.0g)	G 3/8 F
NRF050XXXN38F		2.05 (52.0)	3.30 (2124.0)	1.10 (28.0)	0.92 (23.3)	1.46 (37.0)	0.24 (6.0)	Yes	NB60	NB45	0.8 oz (24.0g)	3/8 NPT F
NRF080XXXG38F		3.23 (82.0)	8.19 (5281.0)	1.34 (34.0)	1.10 (28.0)	1.57 (40.0)	0.24 (6.0)	Yes	NB60	NB45	1.8 oz (51.6g)	G 3/8 F
NRF080XXXN38F		3.23 (82.0)	8.19 (5281.0)	1.34 (34.0)	1.10 (28.0)	1.57 (40.0)	0.24 (6.0)	Yes	NB60	NB45	1.8 oz (51.6g)	3/8 NPT F
NRF100XXXG38F		4.06 (103.0)	12.95 (8332.0)	1.42 (36.0)	1.06 (26.8)	1.57 (40.0)	0.24 (6.0)	Yes	NB60	NB45	2.4 oz (68.4g)	G 3/8 F
NRF100XXXN38F		4.06 (103.0)	12.95 (8332.0)	1.42 (36.0)	1.06 (26.8)	1.57 (40.0)	0.24 (6.0)	Yes	NB60	NB45	2.4 oz (68.4g)	3/8 NPT F

* How to Order: All part numbers with an "XXXX" requires the customer to specify a material type to complete part number. I.E. NRF100NB60N38F (for NBR material). See Chart below for material specifications.
 Fittings: To order fittings, please reference the fitting groups section for the appropriate part numbers. NF indicates no fitting is required.
 The weight of the cups shown is without fittings unless the fitting is standard ie: 1/4 NPTF. For fitting weights, see vacuum fitting section.

Material	Color	Temperature Range
NB60 - NBR	Orange	-4°F to +230°F (-20°C to +110°C)
NB45 - NBR	Green	-4°F to +230°F (-20°C to +110°C)

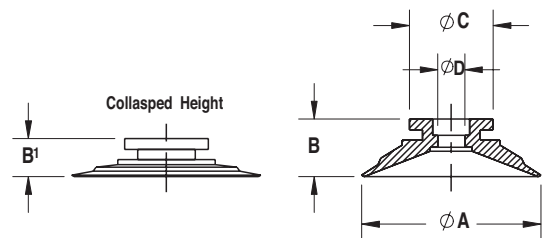



- » The NSF Series of vacuum cups are small flat vacuum cups that are designed to pick up small electronic components.



Specialty Cups: NSF Style

Part Number	A - O.D. in. (mm)	Approx. Area sq. in. (sq. mm)	B - Height in. (mm)	B' - Collapsed Height in. (mm)	C in. (mm)	D - Thru Hole in. (mm)	Cleats	Standard Material	Optional Material	Weight oz (g)	Fitting Group
NSF3.5XXXX	0.14 (3.5)	0.01 (10.0)	0.21 (5.4)	0.20 (5.0)	0.10 (2.5)	0.05 (1.1)	No	NB50, SI50	-	0.02 oz (0.0g)	1
NSF5.5XXXX	0.22 (5.5)	0.04 (24.0)	0.22 (5.5)	0.20 (5.0)	0.11 (2.8)	0.05 (1.2)	No	NB50, SI50	-	0.3 oz (0.0g)	1

* How to Order: All part numbers ending with an "XXXX" requires the customer to specify a material type to complete part number. I.E. BSF3.5NB55 (for NBR material). See Chart below for material specifications.

Fittings: To order fittings, please reference the fitting groups section for the appropriate part numbers. NF indicates no fitting is required. The weight of the cups shown is without fittings unless the fitting is standard ie: 1/4 NPTF. For fitting weights, see vacuum fitting section.

Material	Color	Temperature Range
NB50 - NBR	Black	-4°F to +230°F (-20°C to +110°C)
SI50 - Silicone	Red	-40°F to +482°F (-40°C to +250°C)

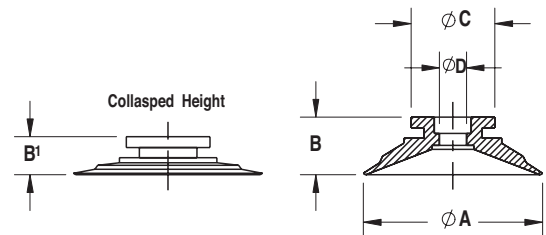

ULTRA MINIATURE FLAT CUPS



» Ultra-Miniature Cups are ideal for use in picking up extremely small parts.



Ultra-Miniature Cups: NVC Style

Part Number		A - O.D. in. (mm)	Approx. Area sq. in. (sq. mm)	B - Height in. (mm)	C in. (mm)	D in. (mm)	E in. (mm)	Cleats	Standard Material	Optional Material	Weight oz (g)	Fitting Group
NVC-VI093-*		0.09 (2.4)	0.01 (4.0)	0.16 (4.1)	0.08 (2.0)	0.03 (0.8)	0.02 (0.5)	No	B	S	0.00 oz (0.0g)	1
NVC-VI125-*		0.13 (3.2)	0.01 (8.0)	0.18 (4.6)	0.10 (2.5)	0.03 (0.8)	0.04 (0.9)	No	B	ESD or S	0.00 oz (0.0g)	1
NVC-VI250-*		0.25 (6.4)	0.05 (32.0)	0.20 (5.1)	0.13 (3.3)	0.06 (1.5)	0.04 (0.9)	No	B	ESD or S	0.00 oz (0.0g)	1
NVC-VI375-*		0.38 (9.5)	0.11 (71.0)	0.25 (6.4)	0.13 (3.3)	0.06 (1.5)	0.04 (0.9)	No	B	ESD or S	0.00 oz (0.1g)	1
NVC-VI500-*		0.50 (12.7)	0.20 (127.0)	0.30 (7.6)	0.16 (4.1)	0.06 (1.5)	0.04 (0.9)	No	B	ESD or S	0.00 oz (0.1g)	1
NVC-VI625-*		0.63 (15.9)	0.31 (198.0)	0.31 (7.9)	0.16 (4.1)	0.06 (1.5)	0.04 (0.9)	No	B	ESD or S	0.01 oz (0.3g)	1
NVC-VI750-*		0.75 (19.1)	0.44 (285.0)	0.32 (8.1)	0.16 (4.1)	0.06 (1.5)	0.04 (0.9)	No	B	ESD or S	0.02 oz (0.5g)	1

* How to Order: All part numbers ending with a dash require customer to specify a material type to complete part number. I.E. NVC-VI093-* (for Buna-N material). See Chart below for material specifications.

Material

- B** - Buna-N static dissipative (ESD-safe) non-marking
- ESD** - Hi-Temp conductive (ESD-safe) silicone
- S** - Hi-Temp (non-ESD-safe) silicone

Color Temperature Range

- Black -5°F to +250°F (-15°C to +121°C)
- Black -22°F to +392°F (-30°C to +200°C)
- Clear -4°F to +572°F (-20°C to +300°C)

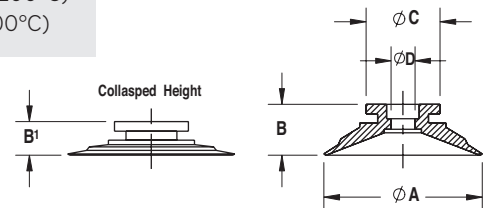





» NOV Series of vacuum cups are designed for unique applications. With a soft flexible oval cup, these cups are made to gently pick up parts. The use of vinyl material provides excellent wear characteristics. These cups are ideal for applications for curved surface objects, electronics (PCB), glass, oily materials, and pharmaceuticals.



Oval Cups: NOV Style

Part Number		A - O.D. in. (mm)	Approx. Area sq. in. (sq. mm)	B - Height in. (mm)	B' - Collapsed Height in. (mm)	C in. (mm)	D - Thru Hole in. (mm)	Cleats	Standard Material	Optional Material	Weight oz (g)	Fitting Group
NOV035X028VI55		1.38x1.10 (35.0x28.0)	1.26 (812.0)	0.96 (24.5)	0.49 (12.5)	- (-)	0.39 (10.0)	No	VI55	-	0.2 oz (5.9g)	6
NOV045X028VI55		1.77x1.10 (45.0x28.0)	1.69 (1092.0)	0.96 (24.5)	0.49 (12.5)	- (-)	0.39 (10.0)	No	VI55	-	0.3 oz (8.2g)	6

Fittings: To order fittings, please reference the fitting groups section for the appropriate part numbers. NF indicates no fitting is required. The weight of the cups shown is without fittings unless the fitting is standard ie: 1/4 NPTF. For fitting weights, see vacuum fitting section 5

Material	Color	Temperature Range
VI55 - Vinyl	Blue	-32°F to +140°F (0°C to +60°C)

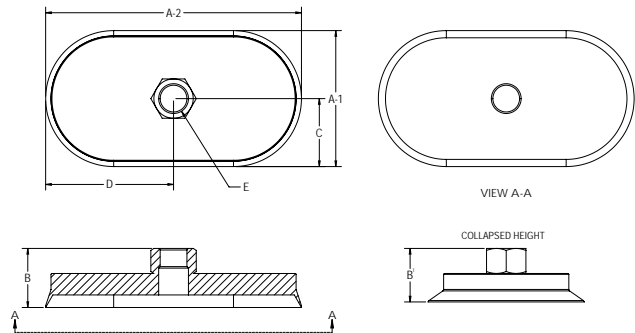

OVAL CUPS



» Oval cups have heavy load capabilities due to their rigid design and large vacuum work area. They have the largest lifting force because they provide the most surface area for a given footprint.



Oval Cups: NVC Style

Part Number		A-1 in. (mm)	A - 2 in. (mm)	Approx. Area sq. in. (sq. mm)	B - Height in. (mm)	B ¹ - Collapsed Height in. (mm)	C in. (mm)	D - Thru Hole in. (mm)	E	F	H	Cleats	Standard Material	Optional Material	Weight oz (g)
NVC-89		1.14 (29.0)	2.78 (70.6)	5.85 (3774.0)	1.13 (28.7)	0.95 (2.41)	0.57 (14.5)	1.39 (35.3)	1/4 NPTF	- (-)	- (-)	No	V	ORV, GS or P	1.0 oz (27g)
NVC-83		1.56 (39.6)	4.09 (103.9)	3.16 (2039.0)	1.30 (33.0)	1.20 (30.5)	0.78 (19.8)	2.05 (51.9)	1/4 NPTF	- (-)	- (-)	No	V	ORV, GS or P	3.2 oz (91g)
NVC-183-2X4		2.00 (50.8)	4.00 (101.6)	7.14 (4606.0)	1.00 (25.4)	0.70 (17.8)	1.00 (25.4)	2.00 (50.8)	1/4 NPTF	- (-)	- (-)	Yes	V	ORV, GS or P	2.7 oz (76g)
NVC-183-2X6		2.00 (50.8)	6.00 (152.4)	11.14 (7187.0)	0.98 (24.9)	0.75 (19.1)	1.00 (25.4)	4.00 (101.6)	1.00 (25.4)	1/4 NPTF	- (-)	Yes	V	ORV, GS or P	4.7 oz (134g)
NVC-90-2X10		2.00 (50.8)	10.00 (254.0)	19.14 (12348.0)	0.82 (20.8)	0.55 (14.0)	1.00 (25.4)	6.50 (165.1)	1.75 (44.5)	1/4 NPTF	- (-)	No	V	ORV, GS or P	4.9 oz (139g)
NVC-90-3X8		3.00 (76.2)	8.00 (203.2)	22.06 (14232.0)	1.10 (27.8)	0.75 (19.1)	1.50 (38.1)	5.00 (127.0)	1.50 (38.1)	3/8 NPTF	- (-)	Yes	V	ORV, GS or P	11.0 oz (312g)
NVC-90-3X10		3.00 (76.2)	10.00 (254.0)	28.06 (18103.0)	1.10 (27.8)	0.73 (18.5)	1.50 (38.1)	7.00 (177.8)	1.50 (38.1)	3/8 NPTF	- (-)	Yes	V	ORV, GS or P	14.0 oz (397g)
NVC-32-3.5X5.0		3.50 (88.9)	5.00 (127.0)	11.87 (7658.0)	1.82 (46.2)	1.02 (25.9)	1.75 (44.5)	2.50 (63.5)	3/8 NPTF	- (-)	- (-)	Yes	V	ORV, GS or P	6.7 oz (190g)
NVC-129		3.25 (82.6)	7.87 (199.9)	23.30 (15032.0)	1.83 (46.5)	0.80 (20.3)	1.63 (41.3)	3.94 (100.0)	1/2 NPTF	- (-)	- (-)	Yes	V	ORV, GS or P	13.2 oz (373g)
NVC-90-6X10		6.00 (152.4)	10.00 (254.0)	58.06 (37458.0)	1.19 (30.2)	0.73 (18.5)	2.00 (50.8)	6.00 (152.4)	2.00 (50.8)	6.00 (152.40)	Consult Factory	Yes	V	ORV, GS or P	24.0 oz (680g)

* How to Order: All part numbers ending with a dash require customer to specify a material type to complete part number. I.E. NVC-129-GS (for Silicone material). See Chart below for material specifications. Fittings: To order fittings, please reference the fitting groups section for the appropriate part numbers. The weight of the cups shown is without fittings unless the fitting is standard ie: 1/4 NPTF. For fitting weights, see vacuum fitting section.
Custom mounting holes available. Consult factory.

Material	Color	Temperature Range
V - Vinyl	Blue	+32°F to +125°F (0°C to +52°C)
ORV - Oil Resistant Vinyl	Black	+32°F to +125°F (0°C to +52°C)
P - Polyurethane	Green	+32°F to +140°F (0°C to +60°C)
GS - Silicone	Gray	-50°F to +392°F (-46°C to +200°C)



Oval

NVC-89

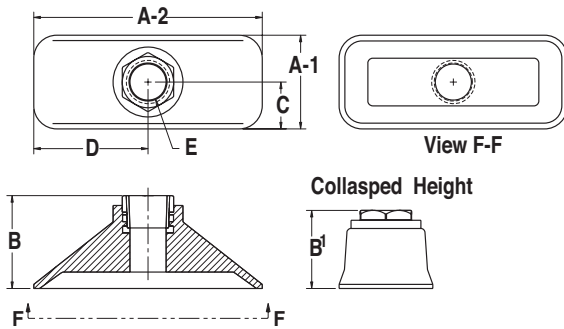

NVC-83

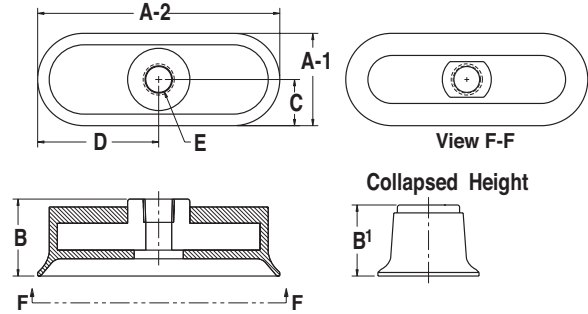

NVC-183-2X4

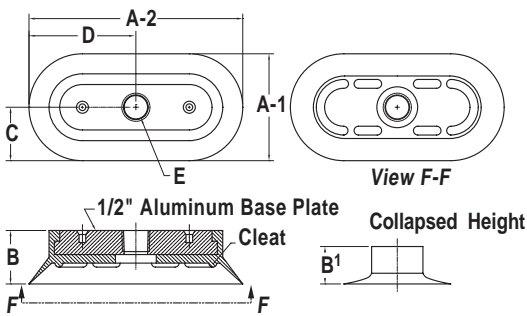

NVC-183-2X6

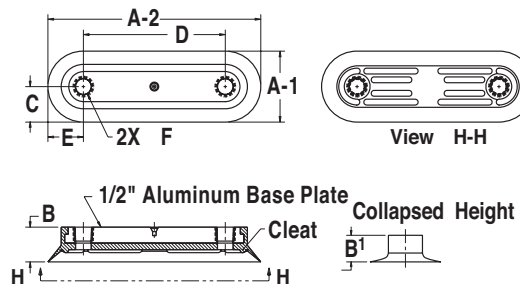

NVC-90-2X10

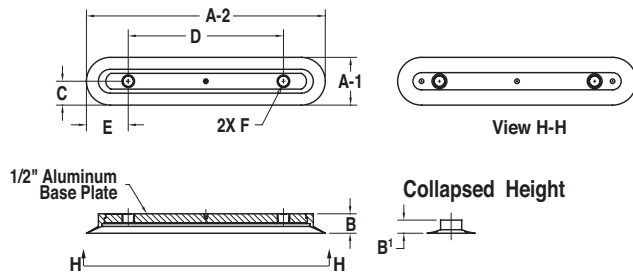

NVC-90-3X10

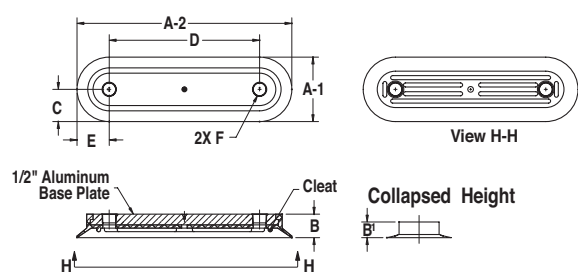

Custom mounting holes available. Consult factory.

OVAL CUPS



Oval

NVC-90-3X8

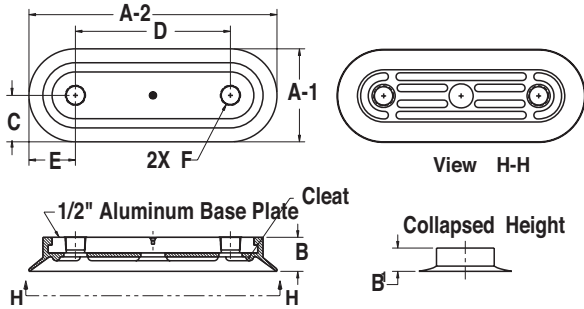

NVC-129

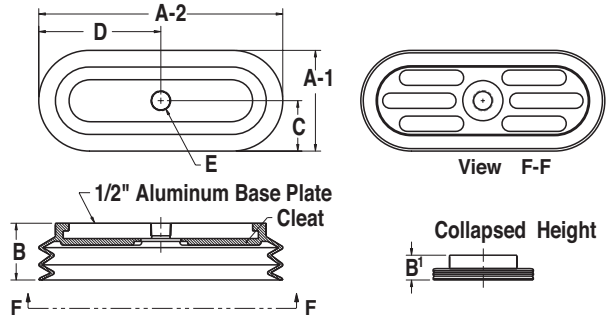

NVC-32-3.5X5.0

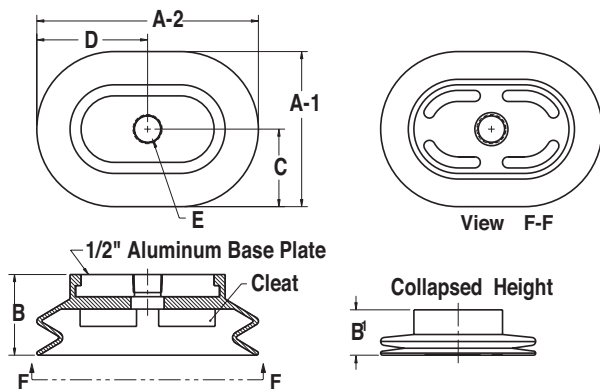

NVC-90-6X10

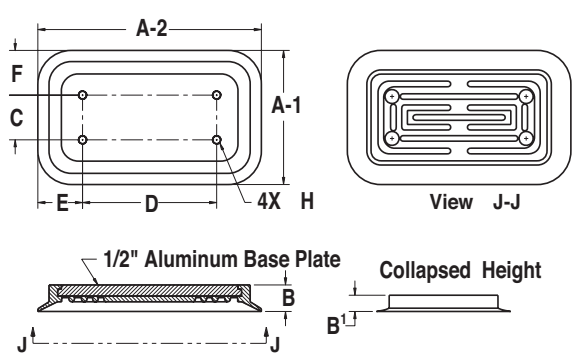

Custom mounting holes available. Consult factory.



» The NBG Series of vacuum cups are a general purpose line of single bellow cups. The single bellow allows the cup to conform to the work piece while accommodating variations in part presentation. With a choice between NBR material for excellent wear capabilities and white silicone for FDA approved for food handling applications, the NBG Series is an ideal fit.



Single Bellows Cups: NBG Style

Part Number		A - O.D. in. (mm)	Approx. Area sq. in. (sq. mm)	B - Height in. (mm)	B' - Collapsed Height in. (mm)	C in. (mm)	D - Thru Hole in. (mm)	Cleats	Standard Material	Optional Material	Weight oz (g)	Fitting Group
NBG006XXXX		0.24 (6.0)	0.04 (28.0)	0.35 (9.0)	0.19 (4.8)	0.30 (7.5)	0.16 (4.0)	Yes	NB55, WS50	CN55, CS50, EP55, FL65, HP55	0.0 oz (0.2g)	13
NBG008XXXX		0.31 (8.00)	0.08 (50.0)	0.35 (9.0)	0.20 (5.0)	0.31 (8.0)	0.16 (4.0)	Yes	NB55, WS50	CN55, CS50, EP55, FL65, HP55	0.0 oz (0.3g)	13
NBG010XXXX		0.39 (10.0)	0.12 (79.0)	0.37 (9.5)	0.26 (6.5)	0.43 (11.0)	0.16 (4.0)	Yes	NB55, WS50	CN55, CS50, EP55, FL65, HP55	0.0 oz (0.6g)	13
NBG015XXXX		0.59 (15.0)	0.27 (177.0)	0.43 (11.0)	0.30 (7.7)	0.47 (12.0)	0.16 (4.0)	Yes	NB55, WS50	CN55, CS50, EP55, FL65, HP55	0.0 oz (0.8g)	13
NBG020XXXX		0.79 (20.0)	0.49 (314.0)	0.51 (13.0)	0.30 (7.5)	0.59 (15.0)	0.18 (4.6)	Yes	NB55, WS50	CN55, CS50, EP55, FL65, HP55	0.1 oz (1.9g)	4
NBG025XXXX		0.98 (25.0)	0.76 (491.0)	0.61 (15.5)	0.35 (9.0)	0.69 (17.5)	0.18 (4.6)	Yes	NB55, WS50	CN55, CS50, EP55, FL65, HP55	0.1 oz (3.2g)	4
NBG030XXXX		1.18 (30.0)	1.10 (707.0)	0.71 (18.0)	0.43 (11.0)	0.79 (20.0)	0.23 (5.8)	Yes	NB55, WS50	CN55, CS50, EP55, FL65, HP55	0.2 oz (5.0g)	45
NBG035XXXX		1.38 (35.0)	2.49 (962.0)	0.72 (18.0)	0.43 (11.0)	0.98 (25.0)	0.23 (5.8)	Yes	NB55, WS50	CN55, CS50, EP55, FL65, HP55	0.3 oz (8.1g)	45
NBG040XXXX		1.57 (40.0)	1.95 (1257.0)	0.71 (18.0)	0.43 (10.8)	0.98 (25.0)	0.23 (5.8)	Yes	NB55, WS50	CN55, CS50, EP55, FL65, HP55	0.4 oz (11.1g)	45
NBG050XXXX		1.97 (50.0)	3.04 (1963.0)	0.79 (20.0)	0.43 (11.0)	1.18 (30.0)	0.30 (7.8)	Yes	NB55, WS50	CN55, CS50, EP55, FL65, HP55	0.8 oz (21.3g)	5
NBG060XXXX		2.36 (60.0)	4.38 (2827.0)	0.79 (20.0)	0.47 (12.0)	1.57 (40.0)	M10X1.25	Yes	NB55, WS50	CN55, CS50, EP55, FL65, HP55	1.3 oz (35.5g)	M10x1.25

* How to Order: All part numbers ending with an "XXXX" requires the customer to specify a material type to complete part number. I.E. NBG015WS50 (for Silicone material). See Chart below for material specifications.

Fittings: To order fittings, please reference the fitting groups section for the appropriate part numbers. NF indicates no fitting is required.

The weight of the cups shown is without fittings unless the fitting is standard ie: 1/4 NPTF. For fitting weights, see vacuum fitting section.

Material	Color	Temperature Range
NB55 - NBR	Black	-4°F to +230°F (-20°C to +110°C)
WS50 - Silicone	White	-40°F to +482°F (-40°C to +250°C)
CN55 - Conductive NBR	Black	-14°F to +212°F (-10°C to +100°C)
CS50 - Conductive Silicone	Black	-22°F to +392°F (-30°C to +200°C)
FL65 - Fluorine Rubber	Black	14°F to +662°F (-10°C to +350°C)
EP55 - EPDM	Grey	-22°F to +302°F (-30°C to +150°C)
HP55 - Mark Free NBR	Black	-4°F to +230°F (-20°C to +110°C)

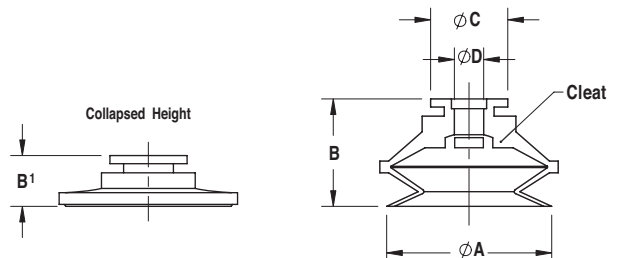

SINGLE BELLOWS CUPS



» The NDB Series of vacuum cups is a polyurethane series of bellow cups. This series is offered in both single durometer and dual durometer material. Single durometer cups provide a lower pricepoint, but dual durometer cups provide a longer overall life. The single bellow cups allow the cup to conform to the work piece while accommodating variation in part presentation.



Single Bellows Cups: NDB Style

Part Number		A - O.D. in. (mm)	Approx. Area sq. in. (sq. mm)	B - Height in. (mm)	B' - Collapsed Height in. (mm)	C in. (mm)	D - Thru Hole in. (mm)	Cleats	Standard Material	Optional Material	Weight oz (g)	Fitting Group
NDB010PU40		0.43 (10.9)	0.15 (93.0)	0.65 (16.5)	0.45 (11.5)	0.35 (9.0)	0.20 (5.0)	Yes	PU40, PU60, PD36	-	0.0 oz (0.9g)	2
NDB015XXXX		0.63 (16.0)	0.31 (201.0)	0.75 (19.0)	0.52 (13.2)	0.35 (9.0)	0.22 (5.5)	Yes	PU40, PU60, PD36	-	0.1 oz (1.5g)	2
NDB020XXXX		0.83 (21.0)	0.54 (346.0)	0.71 (18.0)	0.41 (10.5)	0.47 (12.0)	0.20 (5.0)	Yes	PU40, PU60, PD36	-	0.1 oz (1.9g)	4
NDB030XXXX		1.24 (31.5)	1.21 (779.0)	0.66 (16.8)	0.40 (10.2)	0.66 (16.8)	0.26 (6.5)	Yes	PU40, PU60, PD36	-	0.2 oz (4.6g)	45
NDB040XXXX		1.65 (42.0)	2.15 (1385.0)	0.88 (22.4)	0.54 (13.6)	0.88 (22.4)	0.26 (6.5)	Yes	PU40, PU60, PD36	-	0.4 oz (11.6g)	45
NDB050XXXX		2.07 (52.5)	3.36 (2165.0)	1.15 (29.3)	0.67 (17.0)	1.10 (28.0)	0.41 (10.5)	Yes	PU40, PU60, PD36	-	0.7 oz (20.4g)	12
NDB070XXXXG38F		2.87 (73.0)	5.97 (3848.0)	1.89 (48.0)	0.79 (20.0)	1.38 (35.0)	0.28 (7.0)	Yes	PU40, PU60, PD36	-	2.1 oz (60g)	G 3/8 F
NDB070XXXXG38M		2.87 (73.0)	5.97 (3848.0)	1.83 (46.5)	0.79 (20.0)	1.38 (35.0)	0.24 (6.0)	Yes	PU40, PU60, PD36	-	2.1 oz (60g)	G 3/8 M

* How to Order: All part numbers with an "XXXX" requires the customer to specify a material type to complete part number. I.E. NDB015PU40 (for Polyurethane material). See Chart below for material specifications.
 Fittings: To order fittings, please reference the fitting groups section for the appropriate part numbers. NF indicates no fitting is required.
 The weight of the cups shown is without fittings unless the fitting is standard ie: 1/4 NPTF. For fitting weights, see vacuum fitting section.

Material	Color	Temperature Range
PU40 - Polyurethane	Yellow	+50°F to +140°F (+10°C to +60°C)
PU60 - Polyurethane	Green	+50°F to +140°F (+10°C to +60°C)
PD36 - Polyurethane	Light Blue	+50°F to +140°F (+10°C to +60°C)

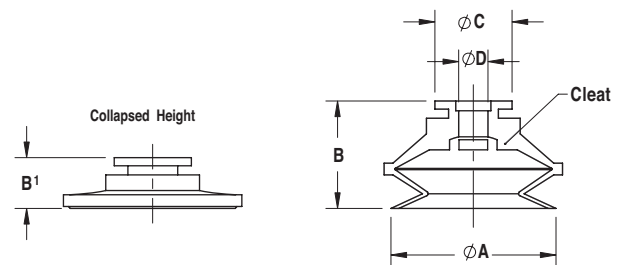

6 SINGLE BELLOWS CUPS



» The NUB Series of vacuum cups are a universal series of single bellow cups. The NUB, NUC, NFD, and NUU Series share common fitting series and offer interchangeability to adapt to different applications. The single bellow NUB Series allows the cup to conform to the work piece while accommodating variation in part presentation.



Single Bellows Cups: NUB Style

Part Number		A - O.D. in. (mm)	Approx. Area sq. in. (sq. mm)	B - Height in. (mm)	B' - Collapsed Height in. (mm)	C in. (mm)	D - Thru Hole in. (mm)	Cleats	Standard Material	Optional Material	Weight oz (g)	Fitting Group
NUB013XXXX		0.51 (13.0)	0.21 (133.0)	0.73 (18.5)	0.43 (11.0)	0.41 (10.40)	0.16 (4.0)	No	NB50, WS45	CN55, CS55, FL65, EP55, HP50	0.1 oz (1.7g)	2
NUB016XXXX		0.63 (16.0)	0.31 (201.0)	0.79 (20.0)	0.45 (11.5)	0.47 (11.90)	0.16 (4.0)	No	NB50, WS45	CN55, CS55, FL65, EP55, HP50	0.1 oz (2.1g)	2
NUB020XXXX		0.79 (20.0)	0.49 (314.0)	0.93 (23.5)	0.51 (13.0)	0.43 (11.00)	0.16 (4.0)	No	NB50, WS45	CN55, CS55, FL65, EP55, HP50	0.1 oz (3.0g)	7
NUB032XXXX		1.26 (32.0)	1.25 (804.0)	1.14 (29.0)	0.59 (15.0)	0.43 (11.00)	0.16 (4.0)	No	NB50, WS45	CN55, CS55, FL65, EP55, HP50	0.3 oz (7.2g)	7
NUB040XXXX		1.57 (40.0)	1.95 (1257.0)	1.95 (34.0)	0.71 (18.0)	0.57 (14.50)	0.28 (7.0)	No	NB50, WS45	CN55, CS55, FL65, EP55, HP50	0.5 oz (13.6g)	27
NUB050XXXX		1.97 (50.0)	3.04 (1963.0)	1.50 (38.0)	0.75 (19.0)	0.57 (14.50)	0.29 (7.0)	No	NB50, WS45	CN55, CS55, FL65, EP55, HP50	0.7 oz (19.9g)	27

* How to Order: All part numbers ending with an "XXXX" requires the customer to specify a material type to complete part number. I.E. NUB020NB50 (for NBR material). See Chart below for material specifications.
 Fittings: To order fittings, please reference the fitting groups section for the appropriate part numbers. NF indicates no fitting is required.
 The weight of the cups shown is without fittings unless the fitting is standard ie: 1/4 NPTF. For fitting weights, see vacuum fitting section.

Material	Color	Temperature Range
NB50 - NBR	Black	-4°F to +230°F (-20°C to +110°C)
WS45 - Silicone	White	-40°F to +482°F (-40°C to +250°C)
CN55 - Conductive NBR	Black	-14°F to +212°F (-10°C to +100°C)
CS55 - Conductive Silicone	Black	-22°F to +392°F (-30°C to +200°C)
FL65 - Fluorine Rubber	Black	14°F to +662°F (-10°C to +350°C)
EP55 - EPDM	Grey	-22°F to +302°F (-30°C to +150°C)
HP50 - Mark Free NBR	Black	-4°F to +230°F (-20°C to +110°C)

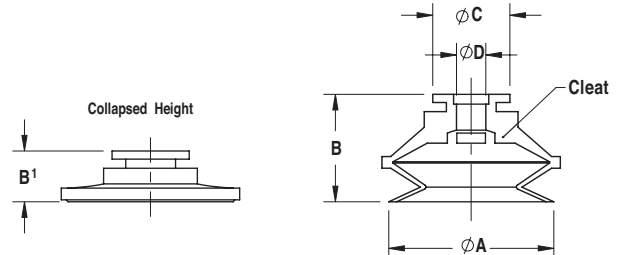

SINGLE BELLOWS CUPS



» The NHB Series of vacuum cups is designed for lifting heavy loads. Unlike most cups where a fitting is pushed into the cup, the NHB Series uses screws to mechanically couple the fitting to the cup. This mechanical cup prevents the cup from separating from the cup.



Single Bellows Cups: NHB Style

Part Number		A - O.D. in. (mm)	Approx. Area sq. in. (sq. mm)	B - Height in. (mm)	B ¹ - Collapsed Height in. (mm)	C in. (mm)	D - Thru Hole in. (mm)	Cleats	Standard Material	Optional Material	Weight oz (g)	Fitting Group
NHB040XXXX		1.63 (41.5)	2.10 (1353.0)	0.51 (13.0)	0.30 (7.5)	1.18 (30.0)	0.24 (6.0)	No	NB55. WS50	FL65	0.6 oz (16.2g)	22
NHB050XXXX		2.05 (52.0)	3.29 (2124.0)	0.65 (16.5)	1.18 (30.0)	1.59 (40.5)	0.24 (6.0)	No	NB55. WS50	FL65	1.1 oz (31.9g)	22
NHB063XXXX		2.56 (65.0)	5.14 (3318.0)	0.85 (21.1)	0.24 (6.0)	1.97 (50.0)	0.31 (8.0)	No	NB55. WS50	FL65	2.2 oz (61g)	23
NHB080XXXX		3.27 (83.0)	8.39 (5411.0)	1.08 (27.5)	0.37 (9.5)	2.52 (64.0)	0.31 (8.0)	No	NB55. WS50	FL65	3.7 oz (103.8g)	23
NHB100XXXX		4.06 (103.0)	12.92 (8332.0)	1.87 (47.5)	0.47 (12.0)	3.15 (80.0)	0.39 (10.0)	No	NB55. WS50	FL65	7.0 oz (198.5g)	24
NHB125XXXX		5.06 (128.5)	20.10 (12969.0)	2.20 (56.0)	0.47 (12.0)	4.13 (105.0)	0.39 (10.0)	No	NB55. WS50	FL65	13.4 oz (380.7g)	24

* How to Order: All part numbers ending with an "XXXX" requires the customer to specify a material type to complete part number. I.E. NHB080WS50 (for Silicone material). See Chart below for material specifications.
 Fittings: To order fittings, please reference the fitting groups section for the appropriate part numbers. NF indicates no fitting is required.
 The weight of the cups shown is without fittings unless the fitting is standard ie: 1/4 NPTF. For fitting weights, see vacuum fitting section.

Material	Color	Temperature Range
NB55 - NBR	Black	-4°F to +230°F (-20°C to +110°C)
WS50 - Silicone	White	-40°F to +482°F (-40°C to +250°C)
FL65 - Fluorine Rubber	Black	+14°F to +662°F (-10°C to +350°C)

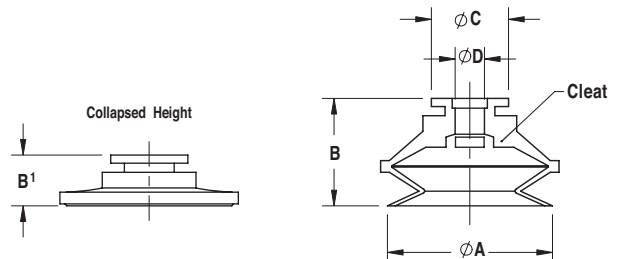

6 SINGLE BELLOWS CUPS



» The NSB Series of vacuum cups is a general purpose line of single bellow cups. The single bellow cup allows the cup to conform to the work piece while accommodating variation in part presentation. With a choice between NBR material for excellent wear capabilities and red silicone material for wide temperature ranges, the NSB Series is an economical choice for various applications.



Single Bellows Cups: NSB Style

Part Number		A - O.D. in. (mm)	Approx. Area sq. in. (sq. mm)	B - Height in. (mm)	B ¹ - Collapsed Height in. (mm)	C in. (mm)	D - Thru Hole in. (mm)	Cleats	Standard Material	Optional Material	Weight oz (g)	Fitting Group
NSB005XXXX		0.23 (5.8)	0.04 (26.0)	0.36 (9.2)	0.30 (7.5)	0.20 (5.2)	0.08 (2.0)	Yes	NB50, SI50	CS55, WS50	0.0 oz (0.2g)	1
NSB008XXXX		0.35 (8.8)	0.09 (61.0)	0.53 (13.5)	0.21 (5.4)	0.24 (6.0)	0.08 (2.0)	Yes	NB50, SI50	CS55, WS50	0.0 oz (0.4g)	1
NSB010XXXX		0.43 (11.0)	0.15 (95.0)	0.63 (16.0)	0.35 (9.0)	0.37 (9.3)	0.14 (3.5)	Yes	NB50, SI50	CS55, WS50	0.0 oz (0.7g)	2
NSB012XXXX		0.47 (12.0)	0.18 (113.0)	0.65 (16.5)	0.43 (11.0)	0.42 (10.8)	0.14 (3.5)	Yes	NB50, SI50	CS55, WS50	0.0 oz (1.3g)	2
NSB020XXXX		0.87 (22.0)	0.59 (380.0)	0.75 (19.0)	0.39 (10.0)	0.57 (14.5)	0.20 (5.0)	Yes	NB50, SI50	CS55, WS50	0.1 oz (3.1g)	4
NSB030XXXX		1.34 (34.0)	1.41 (908.0)	1.02 (26.0)	0.28 (7.0)	0.78 (19.9)	0.25 (6.4)	Yes	NB50, SI50	CS55, WS50	0.3 oz (7.5g)	45
NSB050XXXX		2.09 (53.0)	3.42 (2206.0)	1.38 (35.0)	0.59 (15.0)	1.06 (27.0)	0.41 (10.5)	Yes	NB50, SI50	CS55, WS50	0.8 oz (21.5g)	12

* How to Order: All part numbers ending with an "XXXX" requires the customer to specify a material type to complete part number. I.E. NSB005SI50 (for Silicone material). See Chart below for material specifications.
 Fittings: To order fittings, please reference the fitting groups section for the appropriate part numbers. NF indicates no fitting is required.
 The weight of the cups shown is without fittings unless the fitting is standard ie: 1/4 NPTF. For fitting weights, see vacuum fitting section.

Material	Color	Temperature Range
NB50 - NBR	Black	-4°F to +230°F (-20°C to +110°C)
SI50 - Silicone	Red	-40°F to +482°F (-40°C to +250°C)
CS55 - Conductive Silicone	Black	+14°F to +212°F (-10°C to +100°C)
WS50 - White Silicone	White	-22°F to +392°F (-30°C to +200°C)

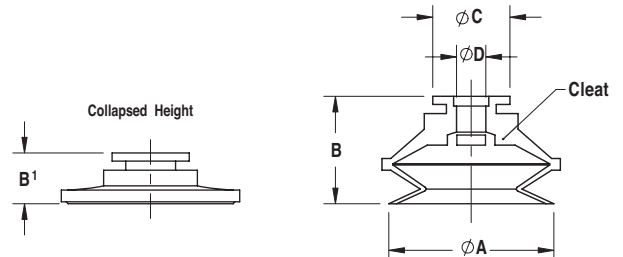

SINGLE BELLOWS CUPS (1 CONVOLUTION)



» Bellows cups conform to curved or uneven surfaces and the bellows sections compensate for inconsistent stack heights.



Single Bellows Cups (1 Convolution): NVC Style

Bellows cups have a pliable outer rim that will conform to curved or uneven surfaces while the bellows sections compensate for inconsistent stack heights. Under vacuum the accordion-style bellows cup will collapse on contact. The collapsing action simulates a short cylinder stroke lifting the product for a short distance, possibly saving the need for a separate lifting mechanism.

This bellows has a total of 2 convolutions

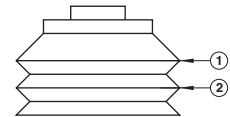

Part Number	Convolution	A - O.D. in. (mm)	Approx. Area sq. in. (sq. mm)	B - Height in. (mm)	B ¹ - Collapsed Height in. (mm)	C in. (mm)	D - Thru Hole in. (mm)	Cleats	Standard Material	Optional Material	Weight oz (g)	Fitting Group	
NVC-B5		1	0.18 (4.6)	0.03 (20.0)	0.50 (12.7)	0.45 (11.4)	0.12 (3.0)	0.06 (1.5)	No	V	ORV, GS or P	0.00 oz (0.0g)	1
NVC-B6		1	0.25 (6.4)	0.05 (31.0)	0.45 (11.4)	0.39 (9.9)	0.14 (3.6)	0.06 (1.5)	No	V	ORV, GS or P	0.00 oz (0.0g)	1
NVC-B10-5		1	0.41 (10.4)	0.13 (85.0)	0.65 (16.5)	0.48 (12.2)	0.31 (7.9)	0.16 (4.1)	No	V	ORV, GS or P	0.02 oz (0.6g)	2
NVC-B3		1	0.51 (13.0)	0.20 (132.0)	0.56 (14.2)	0.28 (7.1)	0.31 (7.9)	0.15 (3.8)	No	V	ORV, GS or P	0.02 oz (0.6g)	2

* How to Order: All part numbers ending with a dash require customer to specify a material type to complete part number. See Chart below for material specifications. Fittings: To order fittings, please reference the fitting groups section for the appropriate part numbers. NF indicates no fitting is required. The weight of the cups shown is without fittings unless the fitting is standard ie: 1/4 NPTF. For fitting weights, see vacuum fitting section.

Material	Color	Temperature Range
V - Vinyl	Blue	+32°F to +125°F (0°C to +52°C)
ORV - Oil Resistant Vinyl	Black	+32°F to +125°F (0°C to +52°C)
P - Polyurethane	Green	+32°F to +140°F (0°C to +60°C)
N - Nitrile	Black	+32°F to +194°F (0°C to +90°C)
C - Chloroprene	Black	-40°F to +230°F (-40°C to +110°C)
GS - Silicone	Gray	-50°F to +392°F (-46°C to +200°C)
S - Silicone	Translucent	-92°F to +392°F (-69°C to +200°C)

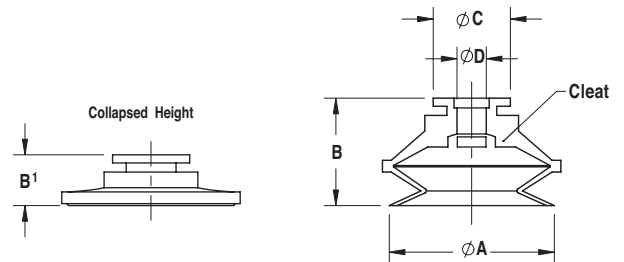



Single Bellows Cups (1 Convolution): NVC Style

Bellows cups have a pliable outer rim that will conform to curved or uneven surfaces while the bellows sections compensate for inconsistent stack heights. Under vacuum the accordion-style bellows cup will collapse on contact. The collapsing action simulates a short cylinder stroke lifting the product for a short distance, possibly saving the need for a separate lifting mechanism.

This bellows has a total of 2 convolutions

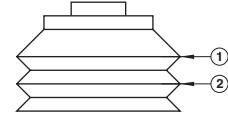

Part Number		Convolutions	A - O.D. in. (mm)	Approx. Area sq. in. (sq.mm)	B - Height in. (mm)	B' - Collapsed Height in. (mm)	C in. (mm)	D - Thru Hole in. (mm)	Cleats	Standard Material	Optional Material	Weight oz (g)	Fitting Group
NVC-B15		1	0.61 (15.5)	0.29 (189.0)	0.81 (20.6)	0.57 (14.5)	0.36 (9.1)	0.14 (3.6)	No	V	ORV, GS or P	0.05 oz (1.0g)	3
NVC-B2		1	0.75 (19.1)	0.44 (285.0)	0.71 (18.0)	0.43 (10.9)	0.51 (13.0)	0.26 (6.6)	No	V	ORV, GS or P	0.07 oz (2.0g)	NF
NVC-B20		1	0.80 (20.3)	0.50 (324.0)	0.78 (19.8)	0.63 (16.0)	0.38 (9.7)	0.16 (4.1)	No	V	ORV, GS or P	0.07 oz (2.0g)	3
NVC-124		1	1.02 (25.9)	0.82 (527.0)	1.45 (36.8)	0.97 (24.6)	0.64 (16.3)	0.34 (8.6)	No	V	ORV, GS or P	0.18 oz (5.0g)	NF
NVC-B1		1	1.20 (30.5)	1.13 (730.0)	1.23 (31.2)	0.84 (21.3)	0.54 (13.7)	- (-)	No	V	ORV, GS or P	0.42 oz (12.0g)	1/8 NPTF
NVC-32C		1	2.00 (50.8)	3.14 (2027.0)	1.61 (40.9)	0.85 (21.6)	0.73 (18.5)	0.38 (9.7)	Yes	V	ORV, GS or P	0.67 oz (19.0g)	NF
NVC-32C-1		1	2.00 (50.8)	3.14 (2027.0)	1.59 (40.4)	0.85 (21.6)	0.75 (19.1)	0.50 (12.7)	Yes	V	ORV, GS or P	0.53 oz (15.0g)	NF
NVC-32C1-F		1	2.00 (50.8)	3.14 (2027.0)	1.50 (38.1)	0.85 (21.6)	1.00 (25.4)	- (-)	Yes	V	ORV, GS or P	1.13 oz (32.0g)	1/4 NPTF
NVC-32B		1	2.78 (70.6)	6.07 (3916.0)	1.82 (46.2)	0.79 (20.1)	1.00 (25.4)	- (-)	Yes	V	ORV, GS or P	1.66 oz (47.0g)	1/4 NPTF

* How to Order: All part numbers ending with a dash require customer to specify a material type to complete part number. See Chart below for material specifications. Fittings: To order fittings, please reference the fitting groups section for the appropriate part numbers. NF indicates no fitting is required. The weight of the cups shown is without fittings unless the fitting is standard ie: 1/4 NPTF. For fitting weights, see vacuum fitting section.

Material	Color	Temperature Range
V - Vinyl	Blue	+32°F to +125°F (0°C to +52°C)
ORV - Oil Resistant Vinyl	Black	+32°F to +125°F (0°C to +52°C)
P - Polyurethane	Green	+32°F to +140°F (0°C to +60°C)
N - Nitrile	Black	+32°F to +194°F (0°C to +90°C)
C - Chloroprene	Black	-40°F to +230°F (-40°C to +110°C)
GS - Silicone	Gray	-50°F to +392°F (-46°C to +200°C)
S - Silicone	Translucent	-92°F to +392°F (-69°C to +200°C)

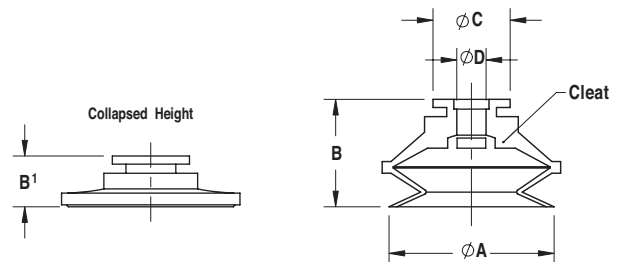

MULTI BELLOWS CUPS



» The NCG Series of vacuum cups is a general purpose line of multi-bellow cups. The multiple bellows allows the cup to conform to the work piece while accommodating variations in part presentation. This cup is offered in NBR material which provides excellent wear capabilities and white silicone FDA compliance material.



Multi Bellows Cups: NCG Style

Part Number		A - O.D. in. (mm)	Approx. Area sq. in. (sq. mm)	B - Height in. (mm)	B' - Collapsed Height in. (mm)	C in. (mm)	D - Thru Hole in. (mm)	Cleats	Standard Material	Optional Material	Weight oz (g)	Fitting Group
NCG010XXXX		0.35 (9.0)	0.10 (64.0)	0.59 (15.0)	0.35 (9.0)	0.35 (9.0)	0.20 (5.0)	Yes	NB55, WS50	CN55, CN50, EP55	0.0 oz (0.7g)	3
NCG015XXXX		0.60 (15.2)	0.28 (181.0)	0.90 (22.8)	0.35 (9.0)	0.39 (10.0)	0.20 (5.0)	Yes	NB55, WS50	CN55, CN50, EP55	0.1 oz (1.7g)	3
NCG018XXXX		0.73 (18.6)	0.42 (272.0)	0.91 (23.0)	0.35 (9.0)	0.39 (10.0)	0.20 (5.0)	Yes	NB55, WS50	CN55, CN50, EP55	0.1 oz (2.0g)	3
NCG020XXXX		0.81 (20.6)	0.52 (333.0)	0.91 (23.0)	0.35 (9.0)	0.39 (10.0)	0.20 (5.0)	Yes	NB55, WS50	CN55, CN50, EP55	0.1 oz (3.1g)	3
NCG030XXXX		1.26 (32.0)	1.25 (804.0)	1.48 (37.5)	0.67 (17.0)	0.71 (18.0)	0.31 (8.0)	Yes	NB55, WS50	CN55, CN50, EP55	0.4 oz (10.8g)	8
NCG040XXXX		1.65 (42.0)	2.15 (1385.0)	1.81 (46.0)	0.67 (17.0)	0.79 (20.0)	0.31 (8.0)	Yes	NB55, WS50	CN55, CN50, EP55	0.8 oz (21.4g)	8
NCG060XXXX		2.44 (62.0)	4.68 (3019.0)	2.17 (55.0)	0.71 (18.0)	0.85 (21.5)	0.31 (8.0)	Yes	NB55, WS50	CN55, CN50, EP55	2.1 oz (58.5g)	8
NCG090XXXX		3.46 (88.0)	9.43 (6082.0)	3.44 (87.5)	1.02 (26.0)	0.98 (25.0)	0.47 (12.0)	Yes	NB55, WS50	CN55, CN50, EP55	5.6 oz (160.0g)	9

* How to Order: All part numbers ending with an "XXXX" requires the customer to specify a material type to complete part number.

I.E. NCG040NB55 (for NBR material). See Chart below for material specifications.

Fittings: To order fittings, please reference the fitting groups section for the appropriate part numbers. NF indicates no fitting is required.

The weight of the cups shown is without fittings unless the fitting is standard ie: 1/4 NPTF. For fitting weights, see vacuum fitting section.

Material	Color	Temperature Range
NB55 - NBR	Black	-4°F to +230°F (-20°C to +110°C)
WS50 - Silicone	White	-40°F to +482°F (-40°C to +250°C)
PU40 - Polyurethane	Yellow	+50°F to +140°F (+10°C to +60°C)
PU60 - Polyurethane	Green	+50°F to +140°F (+10°C to +60°C)
PD36 - Polyurethane	Light Blue	+50°F to +140°F (+10°C to +60°C)
CN55 - Conductive NBR	Black	-14°F to +212°F (-10°C to +100°C)
CN50 - Conductive Silicone	Black	-22°F to +392°F (-30°C to +200°C)
EP55 - EPDM	Black	-22°F to +302°F (-30°C to +150°C)

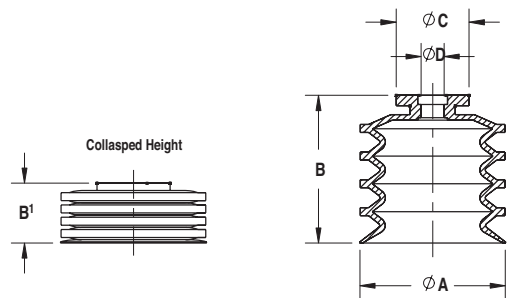

6 MULTI BELLOWS CUPS



» The NSM Series of vacuum cups is a polyurethane series of multi-bellow cups and is offered in both single durometer and dual durometer material. The single durometer cups have a lower pricepoint, but the dual durometer will provide a longer life. The NSM Series has a thinner lip and softer materials allowing for the cup to better conform to curved or uneven surfaces.



Multi Bellows Cups: NSM Style

Part Number		A - O.D. in. (mm)	Approx. Area sq. in. (sq. mm)	B - Height in. (mm)	B' - Collapsed Height in. (mm)	C in. (mm)	D - Thru Hole in. (mm)	Cleats	Standard Material	Optional Material	Weight oz (g)	Fitting Group
NSM025XXXX		0.98 (25.0)	0.76 (491.0)	0.61 (15.5)	0.39 (10.0)	0.47 (12.0)	0.20 (5.0)	Yes	PU55, PD35	-	0.1 oz (1.9g)	4
NSM035XXXX		1.38 (35.0)	1.49 (962.0)	0.88 (22.3)	0.55 (13.9)	0.65 (16.5)	0.20 (5.0)	Yes	PU55, PD35	-	0.2 oz (4.5g)	4
NSM045XXXX		1.77 (45.0)	2.47 (1590.0)	1.15 (29.3)	0.70 (17.8)	0.66 (16.8)	0.26 (6.6)	Yes	PU55, PD35	-	0.4 oz (10.4g)	5
NSM055XXXX		2.17 (55.0)	3.68 (2376.0)	1.43 (36.3)	0.92 (23.4)	1.08 (27.5)	0.41 (10.5)	Yes	PU55, PD35	-	2.3 oz (65.0g)	6

* How to Order: All part numbers ending with an "XXXX" requires the customer to specify a material type to complete part number. I.E. NSM045PU55 (for Polyurethane material). See Chart below for material specifications.
 Fittings: To order fittings, please reference the fitting groups section for the appropriate part numbers. NF indicates no fitting is required.
 The weight of the cups shown is without fittings unless the fitting is standard ie: 1/4 NPTF. For fitting weights, see vacuum fitting section.

Material	Color	Temperature Range
PU55 - Polyurethane	Green	+50°F to +140°F (+10°C to +60°C)
PD35 - Polyurethane	Light Blue/Dark Blue	+50°F to +140°F (+10°C to +60°C)

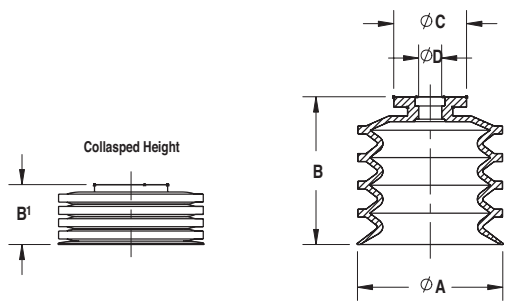

MULTI BELLOWS CUPS



» The NDM Series of vacuum cups is a polyurethane series of multi-bellow cups and is offered in both single and dual durometer material. The single durometer cups have a lower pricepoint, but the dual durometer will provide a longer life. These cups are ideal for applications such as automotive, curved surface objects, masonry, and packaging boxes.



Multi Bellows Cups: NDM Style

Part Number		A - O.D. in. (mm)	Approx. Area sq. in. (sq. mm)	B - Height in. (mm)	B' - Collapsed Height in. (mm)	C in. (mm)	D - Thru Hole in. (mm)	Cleats	Standard Material	Optional Material	Weight oz (g)	Fitting Group
NDM020XXXX		0.83 (21.0)	0.54 (346.0)	0.55 (14.0)	0.41 (10.3)	0.47 (12.0)	0.16 (4.0)	Yes	PU55, PU60, PD36	-	0.1 oz (1.8g)	4
NDM025XXXX		1.02 (26.0)	0.82 (531.0)	0.55 (14.0)	0.46 (11.6)	0.61 (15.4)	0.16 (4.0)	Yes	PU55, PU60, PD36	-	0.1 oz (3.4g)	4
NDM030XXXX		1.18 (30.0)	1.10 (707.0)	0.55 (14.0)	0.52 (13.3)	0.65 (16.5)	0.16 (4.0)	Yes	PU55, PU60, PD36	-	0.1 oz (1.6g)	4
NDM035XXXX		1.38 (35.0)	1.49 (962.0)	0.55 (14.0)	0.61 (15.5)	0.83 (21.0)	0.16 (4.0)	Yes	PU55, PU60, PD36	-	0.2 oz (5.1g)	45
NDM040XXXX		1.57 (40.0)	1.95 (1257.0)	0.55 (14.0)	0.70 (17.8)	0.87 (22.0)	0.16 (4.0)	Yes	PU55, PU60, PD36	-	0.4 oz (10.0g)	45
NDM050XXXX		1.97 (50.0)	3.04 (1963.0)	0.57 (14.5)	0.87 (22.1)	1.08 (27.5)	0.16 (4.0)	Yes	PU55, PU60, PD36	-	0.7 oz (19.7g)	12
NDM070XXXXG38F		2.76 (70.0)	5.97 (3848.0)	0.73 (18.5)	1.18 (29.9)	1.56 (39.7)	0.28 (7.0)	Yes	PU55, PU60, PD36	-	2.3 oz (65.0g)	G 3/8 F
NDM070XXXXG38M		2.76 (70.0)	5.97 (3848.0)	0.77 (19.5)	1.18 (29.9)	1.56 (39.7)	0.24 (6.0)	Yes	PU55, PU60, PD36	-	2.3 oz (65.0g)	G 3/8 M

* How to Order: All part numbers with an "XXXX" requires the customer to specify a material type to complete part number. I.E. NDM070PU60G38M (for Polyurethane material). See Chart below for material specifications.
 Fittings: To order fittings, please reference the fitting groups section for the appropriate part numbers. NF indicates no fitting is required.
 The weight of the cups shown is without fittings unless the fitting is standard ie: 1/4 NPTF. For fitting weights, see vacuum fitting section.

Material	Color	Temperature Range
PU55 - Polyurethane	Green	+50°F to +140°F (+10°C to +60°C)
PU60 - Polyurethane	Blue	+50°F to +140°F (+10°C to +60°C)
PU36 - Dual Durometer	Light Blue/Dark Blue	+50°F to +122°F (+10°C to +50°C)

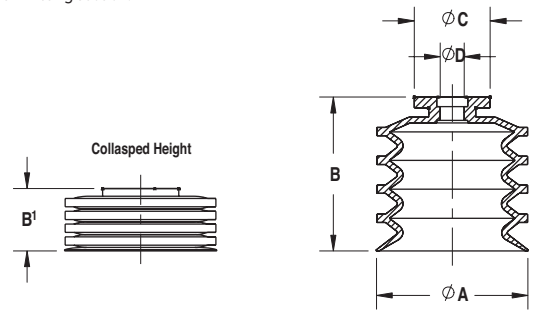

MULTI BELLOWS CUPS (2,3,4 CONVOLUTIONS)



» Bellows cups have a pliable outer rim that will conform to curved or uneven surfaces while the bellows sections compensate for inconsistent stack heights. Under vacuum the accordion-style bellows cup will collapse on contact. The collapsing action simulates a short cylinder stroke lifting the product for a short distance, possibly saving the need for a separate lifting mechanism.



Multi-Bellows Cups (2, 3, 4 Convolution): NVC Style

Part Number	Convolutions	A - O.D. in. (mm)	Approx. Area sq. in. (sq. mm)	B - Height in. (mm)	B' - Collapsed Height in. (mm)	C in. (mm)	D - Thru Hole in. (mm)	Cleats	Standard Material	Optional Material	Weight oz (g)	Fitting Group	
NVC-B10-2		2	0.38 (9.7)	0.11 (73.0)	0.75 (19.1)	0.48 (12.2)	0.19 (4.8)	0.06 (1.5)	No	V	ORV, GS or P	0.0 oz (0.0g)	1
NVC-33A5		3	0.75 (19.1)	0.44 (285.0)	1.00 (25.4)	0.37 (9.4)	0.67 (17.0)	0.44 (11.2)	No	V	ORV, GS or P	0.11 oz (3.0g)	NF
NVC-33A3		2	0.89 (22.6)	0.62 (401.0)	1.02 (25.9)	0.55 (14.0)	0.67 (17.0)	0.43 (10.9)	No	V	ORV, GS or P	0.14 oz (4.0g)	NF
NVC-33A2		2	1.25 (31.8)	1.23 (792.0)	1.43 (36.3)	0.87 (22.1)	0.68 (17.3)	- (-)	No	V	ORV, GS or P	0.6 oz (17.0g)	1/4 NPTF
NVC-33A		3	1.42 (36.1)	1.58 (1022.0)	2.08 (52.8)	1.14 (29.0)	0.68 (17.3)	- (-)	No	V	ORV, GS or P	0.71 oz (20.0g)	1/4 NPTF
NVC-32D		2	2.00 (50.8)	3.14 (2027.0)	1.65 (41.9)	0.75 (19.1)	0.75 (19.1)	- (-)	No	V	ORV, GS or P	1.02 oz (29.0g)	1/4 NPTF
NVC-130		4	3.31 (84.1)	8.60 (5551.0)	2.75 (69.9)	1.14 (29.0)	2.42 (61.5)	- (-)	Yes	V	ORV, GS or P	4.76 oz (135.0g)	3/4 NPTF
NVC-104-4.5		2	4.50 (114.3)	15.90 (10261.0)	2.50 (63.5)	1.50 (38.1)	3.50 (88.9)	- (-)	Yes	V	ORV, GS or P	7.4 oz (209.0g)	3/8 NPTF

* How to Order: All part numbers ending with a dash require customer to specify a material type to complete part number. See Chart below for material specifications.
Fittings: To order fittings, please reference the fitting groups section for the appropriate part numbers. NF indicates no fitting is required. The weight of the cups shown is without fittings unless the fitting is standard ie: 1/4 NPTF. For fitting weights, see vacuum fitting section.

Material

V - Vinyl

ORV - Oil Resistant Vinyl

P - Polyurethane

N - Nitrile

C - Chloroprene

GS - Silicone

S - Silicone

Color

Blue

Black

Green

Black

Black

Gray

Translucent

Temperature Range

+32°F to +125°F (0°C to +52°C)

+32°F to +125°F (0°C to +52°C)

+32°F to +150°F (0°C to +66°C)

+32°F to +194°F (0°C to +90°C)

-40°F to +230°F (-40°C to +110°C)

-50°F to +392°F (-46°C to +200°C)

-92°F to +392°F (-69°C to +200°C)

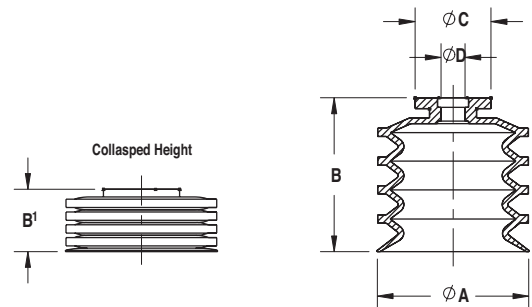

FLAT CUPS



» The NSG Series is a line of flat vacuum cups that have a thin lip. Flat cups allow for a firm grip on the work piece. The flexible lip allows the cup to conform better to variations in workpiece surfaces.



Flat Cups: NSG Style

Part Number		A - O.D. in. (mm)	Approx. Area sq. in. (sq. mm)	B - Height in. (mm)	B ¹ - Collapsed Height in. (mm)	C in. (mm)	D - Thru Hole in. (mm)	Cleats	Standard Material	Optional Material	Weight oz (g)	Fitting Group
NSG015XXXX		0.59 (15.0)	0.27 (177.0)	0.30 (7.5)	0.26 (6.6)	0.33 (8.5)	0.08 (2.0)	Yes	NB55, WS50	CN55, CS55	0.0 oz (0.3g)	13
NSG020XXXX		0.79 (20.0)	0.49 (314.0)	0.39 (10.0)	0.35 (8.8)	0.35 (9.0)	0.08 (2.0)	Yes	NB55, WS50	CN55, CS55	0.0 oz (0.9g)	13
NSG025XXXX		0.98 (25.0)	0.76 (491.0)	0.39 (10.0)	0.33 (8.5)	0.87 (22.0)	0.12 (3.0)	Yes	NB55, WS50	CN55, CS55	0.1 oz (2.3g)	M6X1
NSG030XXXX		1.18 (30.0)	1.10 (707.0)	0.43 (11.0)	0.36 (9.2)	0.87 (22.0)	0.12 (3.0)	Yes	NB55, WS50	CN55, CS55	0.1 oz (2.7g)	M6X1

* How to Order: All part numbers ending with an "XXXX" requires the customer to specify a material type to complete part number. I.E. NSG020NB55 (for NBR material). See Chart below for material specifications.
 Fittings: To order fittings, please reference the fitting groups section for the appropriate part numbers. NF indicates no fitting is required.
 The weight of the cups shown is without fittings unless the fitting is standard ie: 1/4 NPTF. For fitting weights, see vacuum fitting section 5

Material	Color	Temperature Range
NB55 - NBR	Black	-4°F to +230°F (-20°C to +110°C)
CN55 - Conductive NBR	Black	-14°F to +212°F (-10°C to +100°C)
CS55 - Conductive Silicone	Black	-22°F to +392°F (-30°C to +200°C)
WS50 - Silicone	White	-40°F to +482°F (-40°C to +250°C)

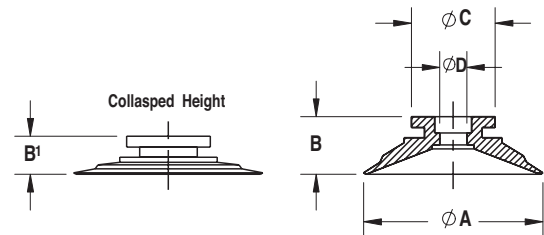





» The NFR Series of flat cups have a thin lip and short travel. This series is very similar to the NSG Series by offering a thin lip to better conform to the workpiece. The shorter stroke of the NFR Series allows for faster cycle times by gripping the workpiece more quickly.

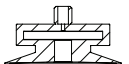

Flat Cups: NFR Style

Part Number		A - O.D. in. (mm)	Approx. Area sq. in. (sq. mm)	B - Height in. (mm)	B' - Collapsed Height in. (mm)	C in. (mm)	D - Thru Hole in. (mm)	Cleats	Standard Material	Optional Material	Weight oz (g)	Fitting Group
NFR015XXX		0.59 (15.0)	0.27 (177.0)	0.30 (7.5)	0.28 (7.0)	0.33 (8.5)	0.08 (2.0)	Yes	NB55, WS50	CN55, CS55	0.0 oz (0.4g)	13
NFR020XXX		0.79 (20.0)	0.49 (314.0)	0.39 (10.0)	0.36 (9.2)	0.33 (8.5)	0.08 (2.0)	Yes	NB55, WS50	CN55, CS55	0.0 oz (0.9g)	13
NFR030XXX		1.18 (30.0)	1.10 (707.0)	0.43 (11.0)	0.42 (10.7)	0.59 (15.0)	0.12 (3.0)	Yes	NB55, WS50	CN55, CS55	0.1 oz (3.3g)	M6X1

* How to Order: All part numbers ending with an "XXXX" requires the customer to specify a material type to complete part number. I.E. NFR015NB55 (for NBR material). See Chart below for material specifications.

Fittings: To order fittings, please reference the fitting groups section for the appropriate part numbers. NF indicates no fitting is required.

The weight of the cups shown is without fittings unless the fitting is standard ie: 1/4 NPTF. For fitting weights, see vacuum fitting sections 5

Material	Color	Temperature Range
NB55 - NBR	Black	-4°F to +230°F (-20°C to +110°C)
CN55 - Conductive NBR	Black	-14°F to +212°F (-10°C to +100°C)
CS55 - Conductive Silicone	Black	-22°F to +392°F (-30°C to +200°C)
WS50 - Silicone	White	-40°F to +482°F (-40°C to +250°C)

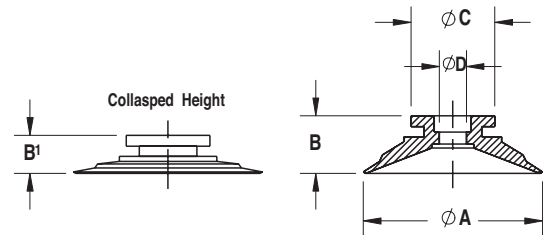

FLAT CUPS



» The NCF Series of vacuum cups is a general-purpose line of flat cups. The NCF Series offers larger diameters and includes cleats. The cleat allows the cup to grip firmly to flat work pieces without losing vacuum.



Flat Cups: NCF Style

Part Number		A - O.D. in. (mm)	Approx. Area sq. in. (sq. mm)	B - Height in. (mm)	B' - Collapsed Height in. (mm)	C in. (mm)	D - Thru Hole in. (mm)	Cleats	Standard Material	Optional Material	Weight oz (g)	Fitting Group
NCF020XXXX		0.87 (22.0)	0.59 (380.0)	0.31 (8.0)	0.28 (7.0)	0.55 (14.0)	0.20 (5.0)	Yes	NB55, SI50	CS55, WS50	0.0 oz (0.2g)	4
NCF025XXXX		1.06 (27.0)	0.89 (573.0)	0.35 (9.0)	0.31 (8.0)	0.55 (13.9)	0.20 (5.0)	Yes	NB55, SI50	CS55, WS50	0.0 oz (0.2g)	4
NCF030XXXX		1.26 (32.0)	1.25 (804.0)	0.39 (10.0)	0.35 (8.8)	0.39 (10.0)	0.20 (5.0)	Yes	NB55, SI50	CS55, WS50	0.0 oz (0.2g)	4

* How to Order: All part numbers ending with an "XXXX" requires the customer to specify a material type to complete part number. I.E. NCF020CS55 (for conductive silicone material). See Chart below for material specifications.
 Fittings: To order fittings, please reference the fitting groups section for the appropriate part numbers. NF indicates no fitting is required.
 The weight of the cups shown is without fittings unless the fitting is standard ie: 1/4 NPTF. For fitting weights, see vacuum fitting section 5

Material	Color	Temperature Range
NB55 - NBR	Black	-4°F to +230°F (-20°C to +110°C)
SI50 - Silicone	Red	-40°F to +482°F (-40°C to +250°C)
CS55 - Conductive Silicone	Black	-22°F to +392°F (-30°C to +200°C)
WS50 - Silicone	White	-40°F to +482°F (-40°C to +250°C)

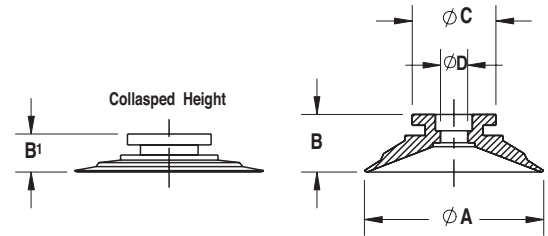



» The NFG Series offers a wide range for flat vacuum cups from 2.5mm to 200mm. Flat cups are ideal for gripping smooth flat surfaces. This series is available in standard NBR material and silicone or 6 other alternative materials and can be adapted to most applications.



Flat Cups: NFG Style

Part Number		A - O.D. in. (mm)	Approx. Area sq. in. (sq. mm)	B - Height in. (mm)	B' - Collapsed Height in. (mm)	C in. (mm)	D - Thru Hole in. (mm)	Cleats	Standard Material	Optional Material	Weight oz (g)	Fitting Group
NFG002XXXX		0.10 (2.5)	0.01 (5.0)	0.16 (4.0)	0.14 (3.5)	0.16 (4.0)	0.08 (2.0)	No	NB55, WS50	CN55, CS55, FL65, EP55, HP50	0.0 oz (0.2g)	25
NFG3.5XXXX		0.15 (3.9)	0.02 (12.0)	0.16 (4.0)	0.14 (3.5)	0.16 (4.0)	0.08 (2.0)	No	NB55, WS50	CN55, CS55, FL65, EP55, HP50	0.0 oz (0.4g)	25
NFG005XXXX		0.20 (5.0)	0.03 (20.0)	0.26 (6.5)	0.22 (5.7)	0.30 (7.5)	0.16 (4.0)	No	NB55, WS50	CN55, CS55, FL65, EP55, HP50	0.0 oz (0.2g)	13
NFG006XXXX		0.26 (6.5)	0.05 (33.0)	0.26 (6.5)	0.22 (5.7)	0.30 (7.5)	0.16 (4.0)	No	NB55, WS50	CN55, CS55, FL65, EP55, HP50	0.0 oz (0.2g)	13
NFG010XXXX		0.41 (10.5)	0.13 (87.0)	0.30 (7.5)	0.24 (6.0)	0.33 (8.5)	0.16 (4.0)	No	NB55, WS50	CN55, CS55, FL65, EP55, HP50	0.0 oz (0.3g)	13
NFG015XXXX		0.61 (15.5)	0.29 (189.0)	0.31 (8.0)	0.24 (6.1)	0.47 (12.0)	0.16 (4.0)	No	NB55, WS50	CN55, CS55, FL65, EP55, HP50	0.0 oz (0.5g)	13
NFG020XXXX		0.83 (21.0)	0.54 (346.0)	0.39 (10.0)	0.30 (7.7)	0.59 (15.0)	0.24 (6.0)	No	NB55, WS50	CN55, CS55, FL65, EP55, HP50	0.1 oz (1.6g)	4
NFG025XXXX		1.00 (25.5)	0.79 (511.0)	0.55 (14.0)	0.43 (11.0)	0.63 (16.0)	0.24 (6.0)	No	NB55, WS50	CN55, CS55, FL65, EP55, HP50	0.1 oz (2.8g)	45
NFG030XXXX		1.18 (30.0)	1.10 (707.0)	0.47 (12.0)	0.39 (10.0)	0.55 (14.0)	0.24 (6.0)	No	NB55, WS50	CN55, CS55, FL65, EP55, HP50	0.1 oz (3.5g)	45
NFG035XXXX		1.42 (36.0)	1.58 (1018.0)	0.55 (14.0)	0.43 (11.0)	0.83 (21.0)	0.24 (6.0)	No	NB55, WS50	CN55, CS55, FL65, EP55, HP50	0.2 oz (6.4g)	45
NFG040XXXX		1.65 (42.0)	2.15 (1385.0)	0.55 (14.0)	0.41 (10.5)	0.94 (24.0)	0.24 (6.0)	No	NB55, WS50	CN55, CS55, FL65, EP55, HP50	0.3 oz (8.5g)	45
NFG050XXXX		2.01 (51.0)	3.17 (2043.0)	0.59 (15.0)	0.43 (11.0)	1.06 (27.0)	0.31 (8.0)	No	NNB55, WS50	CN55, CS55, FL65, EP55, HP50	0.3 oz (9.8g)	5
NFG060XXXX		2.36 (60.0)	4.38 (2827.0)	0.63 (16.0)	0.43 (11.0)	1.50 (38.0)	0.35 (8.8)	No	NB55, WS50	CN55, CS55, FL65, EP55, HP50	0.9 oz (25.2g)	G 1/8 F
NFG080XXXX		3.15 (80.0)	7.79 (5027.0)	0.71 (18.0)	0.47 (12.0)	2.07 (52.5)	0.35 (8.8)	No	NB55, WS50	CN55, CS55, FL65, EP55, HP50	1.7 oz (48.0g)	1/8 NPT F
NFG095XXXX		3.66 (93.0)	10.53 (6793.0)	0.73 (18.5)	0.47 (12.0)	2.64 (67.0)	0.35 (8.8)	No	NB55, WS50	CN55, CS55, FL65, EP55, HP50	2.6 oz (72.5g)	1/8 NPT F
NFG120XXXX		4.72 (120.0)	17.53 (11310.0)	0.94 (24.0)	0.71 (18.0)	3.57 (90.6)	0.55 (14.0)	No	NB55, WS50	CN55, CS55, FL65, EP55, HP50	5.7 oz (162.0g)	24
NFG150XXXX		5.91 (150.0)	27.39 (17671.0)	1.22 (31.0)	0.87 (22.0)	4.13 (105.0)	0.51 (13.0)	No	NB55, WS50	CN55, CS55, FL65, EP55, HP50	11.6 oz (330.1g)	24

Flat Cups: NFG Style

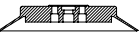
Part Number	A - O.D. in. (mm)	Approx. Area sq. in. (sq. mm)	B - Height in. (mm)	B' - Collapsed Height in. (mm)	C in. (mm)	D - Thru Hole in. (mm)	Cleats	Standard Material	Optional Material	Weight oz (g)	Fitting Group
NFG150WS60 	5.91 (150.0)	27.39 (17671.0)	1.22 (31.0)	0.87 (22.0)	4.13 (105.0)	0.51 (13.0)	No	NB55, WS50	CN55, CS55, FL65, EP50, HD60	11.6 oz (330.1g)	24
NFG200XXX 	5.91 (150.0)	48.69 (31416.0)	1.42 (36.0)	0.91 (23.0)	5.54 (140.8)	0.51 (13.0)	No	NB55, WS50	CN55, CS55, FL65, EP50, HD60	19.4 oz (550.0g)	24

* How to Order: All part numbers with an "XXXX" requires the customer to specify a material type to complete part number. I.E. NFG002NB55 (for NBR material). See Chart below for material specifications.
 Fittings: To order fittings, please reference the fitting groups section for the appropriate part numbers. NF indicates no fitting is required.
 The weight of the cups shown is without fittings unless the fitting is standard ie: 1/4 NPTF. For fitting weights, see vacuum fitting section 5

Material	Color	Temperature Range
NB55 - NBR	Black	4°F to +230°F (-20°C to +110°C)
WS50 - Silicone	White	-40°F to +482°F (-40°C to +250°C)
CN55 - Conductive NBR	Black	-14°F to +212°F (-10°C to +100°C)
CS55 - Conductive Silicone	Black	-22°F to +392°F (-30°C to +200°C)
FL65 - Fluorine Rubber	Black	14°F to +662°F (-10°C to +350°C)
EP50 - EPDM	Grey	-22°F to +302°F (-30°C to +150°C)
HD60 - High Temp./Mark Free	Blue	+14°F to +356°F (-10°C to +180°C)

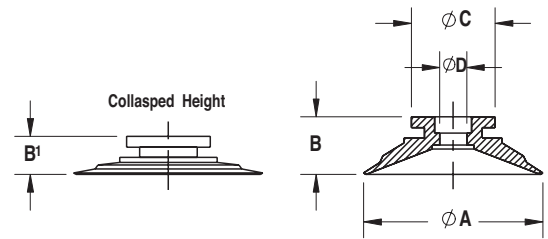



» The NUU is part of the universal cup group that uses common fitting series. The smooth cup allows the cup to apply even gripping forces to the work piece.



Flat Cups: NUU Style

Part Number		A - O.D. in. (mm)	Approx. Area sq. in. (sq. mm)	B - Height in. (mm)	B' - Collapsed Height in. (mm)	C in. (mm)	D - Thru Hole in. (mm)	Cleats	Standard Material	Optional Material	Weight oz (g)	Fitting Group
NUU020XXXX		0.79 (20.0)	0.49 (314.0)	0.55 (14.0)	0.39 (10.0)	0.59 (15.0)	0.16 (4.0)	No	NB50, WS45	CN55, CS55, FL65, EP55, HP50	0.1 oz (1.5g)	7
NUU025XXXX		0.98 (25.0)	0.76 (491.0)	0.55 (14.0)	0.39 (10.0)	0.59 (15.0)	0.16 (4.0)	No	NB50, WS45	CN55, CS55, FL65, EP55, HP50	0.1 oz (2.0g)	7
NUU032XXXX		1.26 (32.0)	1.25 (804.0)	0.57 (14.5)	0.39 (10.0)	0.59 (15.0)	0.16 (4.0)	No	NB50, WS45	CN55, CS55, FL65, EP55, HP50	0.1 oz (2.4g)	7
NUU040XXXX		1.57 (40.0)	1.95 (1257.0)	0.73 (18.5)	0.47 (12.0)	0.71 (18.0)	0.28 (7.0)	No	NB50, WS45	CN55, CS55, FL65, EP55, HP50	0.2 oz (6.0g)	27
NUU050XXXX		1.97 (50.0)	3.04 (1963.0)	0.77 (19.5)	0.47 (12.0)	0.71 (18.0)	0.28 (7.0)	No	NB50, WS45	CN55, CS55, FL65, EP55, HP50	0.3 oz (7.9g)	27

* How to Order: All part numbers ending with an "XXXX" requires the customer to specify a material type to complete part number. I.E. NUU020NB50 (for NBR material). See Chart below for material specifications.

Fittings: To order fittings, please reference the fitting groups section for the appropriate part numbers. NF indicates no fitting is required.

The weight of the cups shown is without fittings unless the fitting is standard ie: 1/4 NPTF. For fitting weights, see vacuum fitting section.

Material	Color	Temperature Range
NB50 - NBR	Black	-4°F to +230°F (-20°C to +110°C)
WS45 - Silicone	White	-40°F to +482°F (-40°C to +250°C)
CN55 - Conductive NBR	Black	-14°F to +212°F (-10°C to +100°C)
CS55 - Conductive Silicone	Black	-22°F to +392°F (-30°C to +200°C)
FL65 - Fluorine Rubber	Black	14°F to +662°F (-10°C to +350°C)
EP55 - EPDM	Grey	-22°F to +302°F (-30°C to +150°C)
HP50 - Mark Free NBR	Black	-4°F to +230°F (-20°C to +110°C)

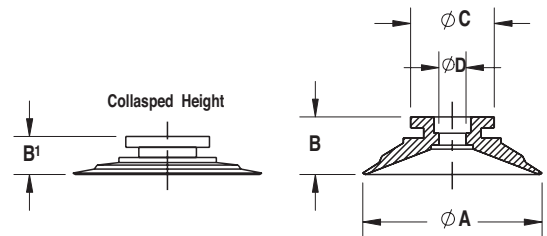

FLAT CUPS



» The NUC Series is designed to lift large heavy objects.
The cup bolts onto a ridged plate ensuring the cup will not peel off the fitting when carrying large objects.



Flat Cups: NUC Style

Part Number		A - O.D. in. (mm)	Approx. Area sq. in. (sq. mm)	B - Height in. (mm)	B' - Collapsed Height in. (mm)	C in. (mm)	D - Thru Hole in. (mm)	Cleats	Standard Material	Optional Material	Weight oz (g)	Fitting Group
NUC020XXXX		0.79 (20.0)	0.49 (314.0)	0.55 (14.0)	0.48 (12.2)	0.59 (15.0)	0.16 (4.0)	Yes	NB50, WS45	CN55, CS55, FL65, EP55	0.1 oz (1.7g)	7
NUC025XXXX		0.98 (25.0)	0.76 (491.0)	0.55 (14.0)	0.48 (12.2)	0.59 (15.0)	0.16 (4.0)	Yes	NB50, WS45	CN55, CS55, FL65, EP55	0.1 oz (2.0g)	7
NUC032XXXX		1.26 (32.0)	1.25 (804.0)	0.57 (14.5)	0.48 (12.2)	0.59 (15.0)	0.16 (4.0)	Yes	NB50, WS45	CN55, CS55, FL65, EP55	0.1 oz (2.7g)	7
NUC040XXXX		1.57 (40.0)	1.95 (1257.0)	0.73 (18.5)	0.60 (15.2)	0.71 (18.0)	0.28 (7.0)	Yes	NB50, WS45	CN55, CS55, FL65, EP55	0.2 oz (6.1g)	27
NUC050XXXX		1.97 (50.0)	3.04 (1963.0)	0.77 (19.5)	0.62 (15.7)	0.71 (18.0)	0.28 (7.0)	Yes	NB50, WS45	CN55, CS55, FL65, EP55	0.3 oz (8.3g)	27

* How to Order: All part numbers ending with an "XXXX" requires the customer to specify a material type to complete part number. I.E. NUC050NB50 (for NBR material). See Chart below for material specifications.
Fittings: To order fittings, please reference the fitting groups section for the appropriate part numbers. NF indicates no fitting is required.
The weight of the cups shown is without fittings unless the fitting is standard ie: 1/4 NPTF. For fitting weights, see vacuum fitting section.

Material	Color	Temperature Range
NB50 - NBR	Black	-4°F to +230°F (-20°C to +110°C)
WS45 - Silicone	White	-40°F to +482°F (-40°C to +250°C)
CN55 - Conductive NBR	Black	-14°F to +212°F (-10°C to +100°C)
CS55 - Conductive Silicone	Black	-22°F to +392°F (-30°C to +200°C)
FL65 - Fluorine Rubber	Black	14°F to +662°F (-10°C to +350°C)
EP55 - EPDM	Black	-22°F to +302°F (-30°C to +150°C)

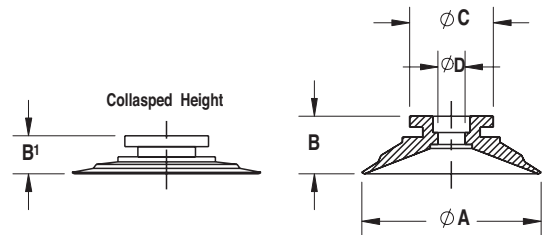



» The NFH Series is designed to lift large heavy objects. The cup bolts onto a ridged plate ensuring the cup will not peel off the fitting when carrying large objects.



Flat Cups: NFH Style

Part Number		A - O.D. in. (mm)	Approx. Area sq. in. (sq. mm)	B - Height in. (mm)	B' - Collapsed Height in. (mm)	C in. (mm)	D - Thru Hole in. (mm)	Cleats	Standard Material	Optional Material	Weight oz (g)	Fitting Group
NFH040NB55		1.65 (42.0)	2.15 (1385.0)	0.45 (11.5)	0.28 (7.0)	1.26 (32.0)	0.24 (6.0)	Yes	NB55, WS50	FL65	0.5 oz (13.9g)	22
NFH050XXXX		2.05 (52.0)	3.29 (2124.0)	0.45 (11.5)	0.33 (8.5)	1.65 (42.0)	0.24 (6.0)	Yes	NB55, WS50	FL65	0.9 oz (25.4g)	22
NFH063XXXX		2.56 (65.0)	5.14 (3318.0)	0.57 (14.5)	0.33 (8.5)	2.01 (51.0)	0.31 (8.0)	Yes	NB55, WS50	FL65	1.8 oz (50.1g)	23
NFH080XXXX		3.23 (82.0)	8.19 (5281.0)	0.65 (16.5)	0.33 (8.5)	2.68 (68.0)	0.31 (8.0)	Yes	NB55, WS50	FL65	2.7 oz (77.1g)	23
NFH100XXXX		4.06 (103.0)	12.92 (8332.0)	0.83 (21.0)	0.33 (8.5)	3.15 (80.0)	0.39 (10.0)	Yes	NB55, WS50	FL65	5.5 oz (154.8g)	24
NFH125XXXX		5.00 (127.0)	19.63 (12668.0)	0.83 (21.0)	0.45 (11.5)	4.09 (104.0)	0.39 (10.0)	Yes	NB55, WS50	FL65	9.7 oz (274.0g)	24

* How to Order: All part numbers ending with an "XXXX" requires the customer to specify a material type to complete part number. I.E. NFH125WS50 (for Silicone material). See Chart below for material specifications.

Fittings: To order fittings, please reference the fitting groups section for the appropriate part numbers. NF indicates no fitting is required. The weight of the cups shown is without fittings unless the fitting is standard ie: 1/4 NPTF. For fitting weights, see vacuum fitting section.

Material	Color	Temperature Range
NB55 - NBR	Black	-4°F to +230°F (-20°C to +110°C)
WS50 - Silicone	White	-40°F to +482°F (-40°C to +250°C)
FL65 - Fluorine Rubber	Black	14°F to +662°F (-10°C to +350°C)

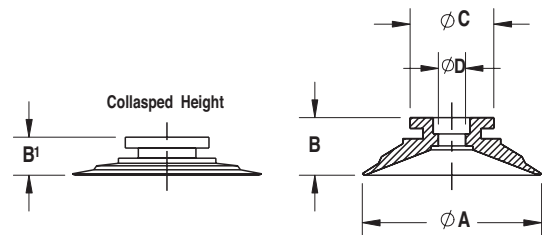

FLAT CUPS



» The NPF Series of polyurethane round flat cups with cleats offers extended life compared to the NBR or silicone material. These cups have integrated cleats providing an excellent grip on the work piece and reduces lateral slippage.



Flat Cups: NPF Style

Part Number		A - O.D. in. (mm)	Approx. Area sq. in. (sq. mm)	B - Height in. (mm)	B' - Collapsed Height in. (mm)	C in. (mm)	D - Thru Hole in. (mm)	Cleats	Standard Material	Optional Material	Weight oz (g)	Fitting Group
NPF020XXXX		0.26 (22.0)	0.59 (380.0)	0.34 (8.6)	0.28 (7.0)	0.47 (12.0)	0.20 (5.0)	Yes	PU40, PU60	-	0.0 oz (1.2g)	4
NPF030XXXX		1.22 (31.0)	1.17 (755.0)	0.41 (10.5)	0.33 (8.5)	0.62 (15.8)	0.20 (5.0)	Yes	PU40, PU60	-	0.1 oz (2.4g)	4
NPF040XXXX		1.61 (41.0)	2.05 (1320.0)	0.55 (14.0)	0.45 (11.5)	0.83 (21.0)	0.26 (6.5)	Yes	PU40, PU60	-	0.2 oz (5.7g)	45

* How to Order: All part numbers ending with an "XXXX" requires the customer to specify a material type to complete part number. I.E. NPF020UU40 (for Polyurethane material). See Chart below for material specifications.
 Fittings: To order fittings, please reference the fitting groups section for the appropriate part numbers. NF indicates no fitting is required.
 The weight of the cups shown is without fittings unless the fitting is standard ie: 1/4 NPTF. For fitting weights, see vacuum fitting section.

Material	Color	Temperature Range
PU40 - Polyurethane	Yellow	+50°F to +122°F (+10°C to +60°C)
PU60 - Polyurethane	Green	+50°F to +122°F (+10°C to +60°C)

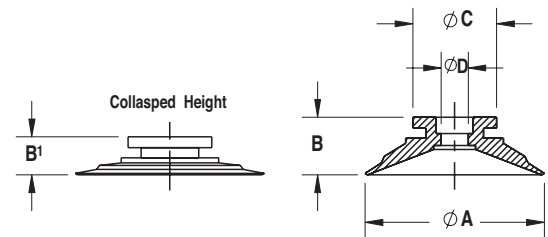



» Flat cups without cleats are flexible and work well in applications that do not require lifting heavy loads. Flat cups with cleats are strong with a rigid, low profile that will lift heavy loads. The low profile allows heavy loads to be lifted vertically without the cup "peeling" away from the product surface or deforming the object being lifted. These cups perform well when gripping smooth, flat, heavy objects such as steel or glass.



Flat Cups (with or without Cleats): NVC Style

Part Number		A - O.D. in. (mm)	Approx. Area sq. in. (sq. mm)	B - Height in. (mm)	B' - Collapsed Height in. (mm)	C in. (mm)	D - Thru Hole in. (mm)	Cleats	Standard Material	Optional Material	Weight oz (g)	Fitting Group
NVC-1		0.22 (5.6)	0.04 (25.0)	0.21 (5.3)	0.19 (4.8)	0.22 (5.6)	0.06 (1.5)	No	V	ORV, GS or P	0.0 oz (0.0g)	NF
NVC-165A		0.37 (9.4)	0.11 (69.0)	0.25 (6.4)	0.22 (5.6)	0.37 (9.4)	0.21 (5.3)	No	V	ORV, GS or P	0.0 oz (0.0g)	NF
NVC-25		0.59 (15.0)	0.27 (176.0)	0.53 (13.5)	0.53 (13.5)	0.46 (11.7)	0.25 (6.4)	No	V	ORV, GS or P	0.04 oz (1.0g)	NF
NVC-36B		1.02 (25.9)	0.82 (527.0)	0.34 (8.6)	0.25 (6.4)	0.56 (14.2)	0.24 (6.1)	Yes	V	ORV, GS or P	0.04 Oz (1.0g)	NF
NVC-10		1.04 (26.4)	0.85 (548.0)	0.90 (22.9)	0.70 (17.8)	0.62 (15.7)	- (-)	No	V	ORV, GS or P	0.32 oz (9g)	1/8 NPTF
NVC-11		1.19 (30.2)	1.11 (718.0)	0.88 (22.4)	0.75 (19.1)	0.75 (19.1)	- (-)	No	V	ORV, GS or P	0.49 oz (14g)	1/4 NPTF
NVC-2EA		1.34 (34.0)	1.41 (910.0)	0.90 (22.9)	0.83 (21.1)	0.62 (15.7)	- (-)	Yes	V	ORV, GS or P	0.21 oz (6g)	1/8 NPTM
NVC-12		1.40 (35.6)	1.54 (993.0)	0.82 (20.8)	0.75 (19.1)	0.75 (19.1)	- (-)	No	V	ORV, GS or P	0.56 oz (16g)	1/4 NPTF
NVC-37A		1.51 (38.4)	1.79 (1115.0)	1.19 (30.2)	0.92 (23.4)	0.89 (22.6)	- (-)	No	V	ORV, GS or P	0.67 oz (19g)	1/4 NPTF
NVC-8		1.51 (38.4)	1.79 (1155.0)	0.56 (14.2)	0.43 (10.9)	0.55 (14.0)	0.23 (5.8)	No	V	ORV, GS or P	0.21 oz (6g)	NF
NVC-168		2.00 (50.8)	3.14 (2027.0)	1.02 (25.9)	0.68 (17.3)	1.10 (27.9)	- (-)	No	V	ORV, GS or P	0.99 oz (28g)	1/4 NPTF
NVC-59		2.00 (50.8)	3.14 (2027.0)	1.00 (25.4)	0.82 (20.8)	1.53 (38.9)	- (-)	Yes	V	ORV, GS or P	2.08 oz (59g)	1/4 NPTF
NVC-49		2.44 (62.0)	4.68 (3017.0)	2.20 (55.9)	1.99 (50.5)	1.04 (26.4)	- (-)	Yes	V	ORV, GS or P	1.52 oz (43g)	1/4 NPTF
NVC-106		2.50 (63.5)	4.91 (3167.0)	1.18 (30.0)	0.80 (20.3)	1.09 (27.7)	- (-)	No	V	ORV, GS or P	1.02 oz (29g)	1/4 NPTF
NVC-30		3.06 (77.7)	7.35 (4744.0)	1.45 (36.8)	1.10 (27.9)	1.15 (29.2)	- (-)	No	V	ORV, GS or P	2.61 oz (74g)	1/4 NPTF
NVC-27A		3.25 (82.6)	8.30 (5352.0)	1.20 (30.5)	0.95 (24.1)	2.23 (56.6)	- (-)	Yes	V	ORV, GS or P	3.28 oz (93g)	1/4 NPTF

Flat Cups (with or without Cleats): NVC Style

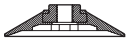
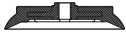
Part Number		A - O.D. in. (mm)	Approx. Area sq. in. (sq. mm)	B - Height in. (mm)	B' - Collapsed Height in. (mm)	C in. (mm)	D - Thru Hole in. (mm)	Cleats	Standard Material	Optional Material	Weight oz (g)	Fitting Group
NVC-27		4.25 (108.0)	14.19 (9152.0)	1.30 (33.0)	0.85 (21.6)	2.73 (69.3)	- (-)	Yes	V	ORV, GS or P	4.03 oz (122g)	1/4 NPTF
NVC-63		4.75 (120.7)	17.72 (11432.0)	1.25 (31.8)	0.90 (22.9)	1.67 (42.4)	- (-)	Yes	V	ORV, GS or P	4.09 oz (116g)	3/8 NPTF
NVC-34		6.25 (158.8)	30.68 (19793.0)	1.37 (34.8)	0.85 (21.6)	5.00 (127.0)	- (-)	Yes	V	ORV, GS or P	16.0 oz (454g)	3/8 NPTF

* How to Order: All part numbers ending with a dash require customer to specify a material type to complete part number.

See Chart below for material specifications.

Fittings: To order fittings, please reference the fitting groups section for the appropriate part numbers. NF indicates no fitting is required.

The weight of the cups shown is without fittings unless the fitting is standard ie: 1/4 NPTF. For fitting weights, see vacuum fitting section.

Material	Color	Temperature Range
V - Vinyl	Blue	+32°F to +125°F (0°C to +52°C)
ORV - Oil Resistant Vinyl	Black	+32°F to +125°F (0°C to +52°C)
P - Polyurethane	Green	+32°F to +150°F (0°C to +66°C)
N - Nitrile	Black	+32°F to +194°F (0°C to +90°C)
GS - Silicone	Gray	-50°F to +392°F (-46°C to +200°C)
S - Silicone	Translucent	-92°F to +392°F (-69°C to +200°C)

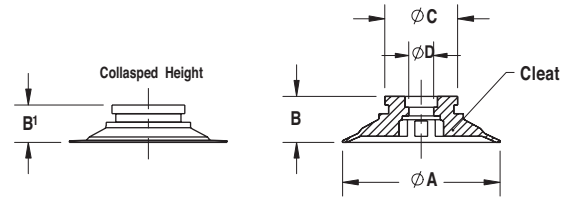

6 VACUUM CUP FITTINGS



Available in imperial and metric threads

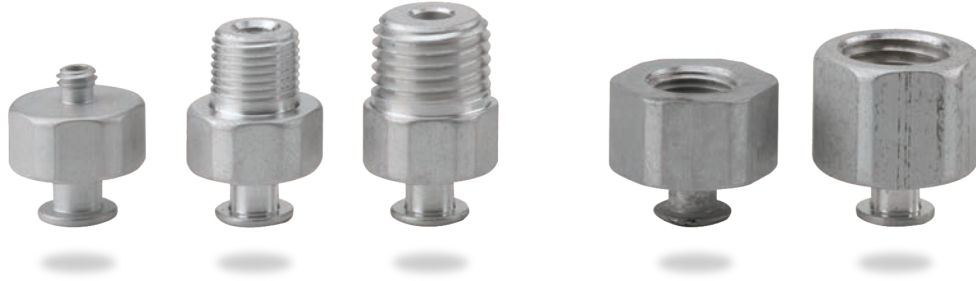

Holds vacuum cups securely

Designed with large thru bores, Norgren fittings connect to vacuum cups, vacuum generators and spring levelers ensuring unrestricted vacuum flow for safe material handling operations. For plumbing flexibility, Norgren offers 12 different fitting groups with various thread sizes.

Fittings

- » Clear chromate coated aluminum or brass
- » Available in metric and imperial threads
- » See cup specification for appropriate fitting group
- » Large through bore to maximize flow
- » Easily replace cup without replacing fitting
- » Holds cup securely

How to Specify

- » Size the cup first based on application requirements. Then choose the fitting size. Please note Norgren's Cup Section includes recommended fitting groups for each cup.
- » For fitting only: order by model # i.e. NVCF4-18F
- » For cup and fitting: order cup part number first and then the numbered extension of the fitting i.e. NVCR-B20P-C-4-14M (note: remove the NVCF from fitting number.)

Fitting Group Selection Guide

Fitting Group	Male										Female										
	10-32	1/8 NPT	1/4 NPT	3/8 NPT	1/2 NPT	M5	G1/8	G1/4	G3/8	G1/2	10-32	1/8 NPT	1/4 NPT	3/8 NPT	1/2 NPT	M5	G1/8	G1/4	G3/8	G1/2	
VCF1	•																				
VCF2	•																				
VCF3	•																				
VCF4	•	•	•				•	•	•				•	•				•			
VCF45	•	•	•				•	•	•				•	•				•	•		
VCF5		•	•	•				•					•	•	•			•		•	
VCF6		•	•	•					•				•	•	•			•		•	
VCF7	•	•							•				•								
VCF8		•	•										•	•						•	
VCF9		•	•	•					•				•	•	•					•	
VCF11		•						•					•					•			
VCF12		•	•	•				•	•	•			•	•	•			•	•	•	
VCF13	•	•					•	•					•					•			
VCF14		•	•	•				•	•	•			•	•	•			•	•	•	
VCF16			•	•				•	•	•			•	•	•			•	•	•	
VCF17				•	•				•	•	•				•					•	•
VCF19		•	•	•				•	•	•			•	•	•			•	•	•	
VCF22													•	•				•	•		
VCF23													•	•	•			•	•	•	
VCF24													•	•	•			•	•	•	
VCF25	•					•															
VCF26			•						•					•					•		
VCF27			•						•					•					•		
VCF28			•						•					•					•		



Fitting Groups 1, 2, 3

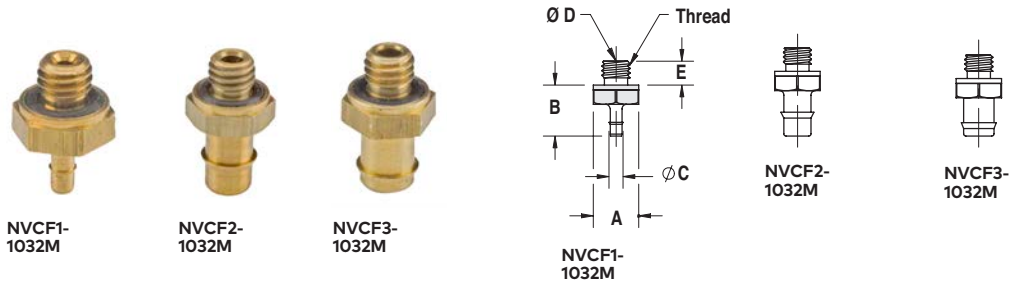

Part Number	Thread Size	Dimensions A - Hex in. (mm)	B in. (mm)	C in. (mm)	D Thru Hole Diameter in. (mm)	E in. (mm)	Weight oz (g)	Material
NVCF1-1032M	10-32 Male	0.31 (7.9)	0.35 (8.9)	0.10 (2.5)	0.05 (1.4)	0.16 (4.1)	0.07 oz (2.0g)	Brass
NVCF2-1032M	10-32 Male	0.31 (7.9)	0.44 (11.2)	0.24 (6.1)	0.09 (2.2)	0.16 (4.1)	0.1 oz (2.8g)	Brass
NVCF3-1032M	10-32 Male	0.31 (7.9)	0.39 (9.9)	0.24 (6.1)	0.09 (2.4)	0.16 (4.1)	0.1 oz (2.8g)	Brass

VACUUM CUP FITTINGS



Fitting Groups 4

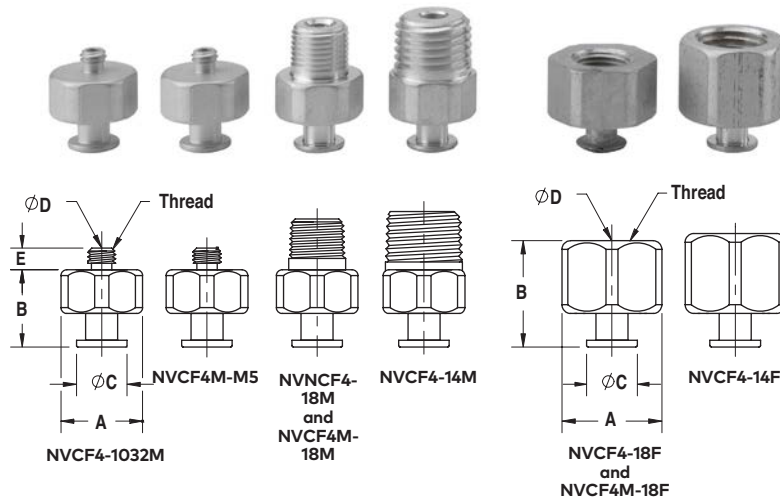

Part Number	Thread Size	Dimensions					Weight	Material
		A - Hex in. (mm)	B in. (mm)	C in. (mm)	D Thru Hole Diameter in. (mm)	E in. (mm)	oz (g)	
NVCF4-1032M	10-32 Male	0.56 (14.3)	0.53 (13.5)	0.35 (8.8)	0.09 (2.4)	0.15 (3.8)	0.2 oz (5.7g)	Aluminum
NVCF4-18M	1/8 NPT Male	0.56 (14.3)	0.53 (13.5)	0.35 (8.8)	0.17 (4.4)	0.35 (8.9)	0.2 oz (5.7g)	Aluminum
NCF4-14M	1/4 NPT Male	0.56 (14.3)	0.53 (13.5)	0.35 (8.8)	0.17 (4.4)	0.40 (10.2)	0.3 oz (8.5g)	Aluminum
NVCF4-18F	1/8 NPT Female	0.69 (17.4)	0.73 (18.5)	0.35 (8.8)	0.17 (4.4)	N/A N/A	0.3 oz (8.5g)	Aluminum
NVCF4-14F	1/4 NPT Female	0.69 (17.4)	0.78 (19.8)	0.35 (8.8)	0.17 (4.4)	N/A N/A	0.3 oz (8.5g)	Aluminum
NVCF4M-M5	M5 X 0.8 Male	0.56 (14.3)	0.53 (13.5)	0.35 (8.8)	0.09 (2.4)	0.15 (3.8)	0.2 oz (5.7g)	Aluminum
NVCF4M-18M	G1/8 Male	0.56 (14.3)	0.53 (13.5)	0.35 (8.8)	0.17 (4.4)	0.35 (8.9)	0.2 oz (5.7g)	Aluminum
NVCF4M-18F	G1/8 Female	0.56 (17.5)	0.73 (18.5)	0.35 (8.8)	0.17 (4.4)	N/A N/A	0.3 oz (8.5g)	Aluminum

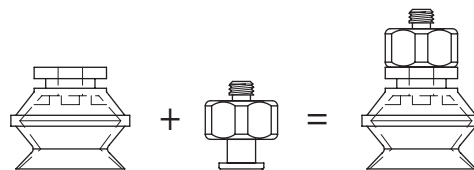

Example: Cup with Fitting

6 VACUUM CUP FITTINGS



Fitting Groups 45

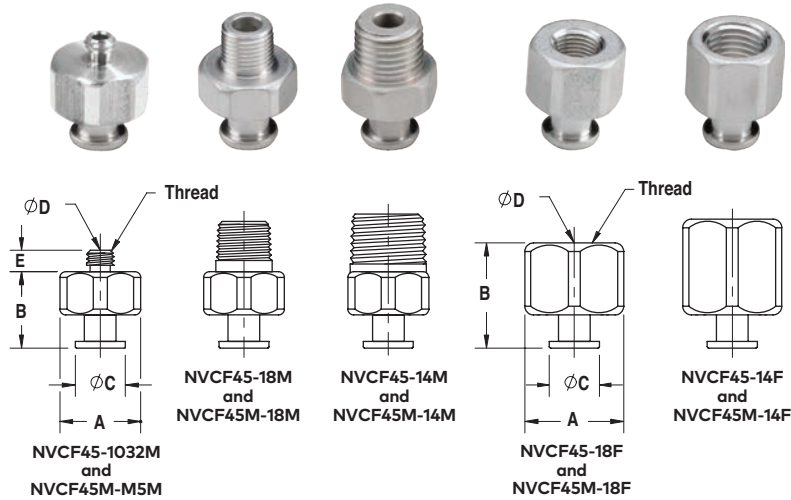

Part Number	Thread Size	Dimensions					Weight oz (g)	Material
		A-Hex in. (mm)	B in. (mm)	C in. (mm)	D Thru Hole Diameter in. (mm)	E in. (mm)		
NVCF45-1032M	10-32 Male	0.75 (19.1)	0.60 (15.1)	0.45 (11.4)	0.09 (2.4)	0.15 (3.8)	0.3 oz (8.5g)	Aluminum
NVCF45-18F	1/8 NPT Female	0.75 (19.1)	0.80 (20.2)	0.45 (11.4)	0.22 (5.6)	N/A	0.3 oz (8.5g)	Aluminum
NVCF45-18M	1/8 NPT Male	0.75 (19.1)	0.60 (15.1)	0.45 (11.4)	0.22 (5.6)	0.35 (8.9)	0.3 oz (8.5g)	Aluminum
NVCF45-14F	1/4 NPT Female	0.75 (19.05)	0.85 (21.6)	0.45 (11.4)	0.22 (5.6)	N/A	0.3 oz (8.5g)	Aluminum
NVCF45-14M	1/4 NPT Male	0.75 (19.1)	0.60 (15.1)	0.45 (11.4)	0.22 (5.6)	0.40 (10.2)	0.3 oz (8.5g)	Aluminum
NVCF45M-M5M	M5 Male	0.75 (19.1)	0.60 (15.1)	0.45 (11.4)	0.09 (2.4)	0.15 (3.8)	0.3 oz (8.5g)	Aluminum
NVCF45M-18F	G 1/8 Female	0.75 (19.1)	0.80 (20.3)	0.45 (11.4)	0.22 (5.6)	N/A	0.3 oz (8.5g)	Aluminum
NVCF45M-18M	G 1/8 Male	0.75 (19.1)	0.60 (15.1)	0.45 (11.4)	0.22 (5.6)	0.35 (8.9)	0.3 oz (8.5g)	Aluminum
NVCF45M-14F	G 1/4 Female	0.75 (19.1)	0.85 (21.6)	0.45 (11.4)	0.22 (5.6)	N/A	0.3 oz (8.5g)	Aluminum
NVCF45M-14M	G 1/4 Male	0.75 (19.1)	0.60 (15.1)	0.45 (11.4)	0.22 (5.6)	0.40 (10.2)	0.3 oz (8.5g)	Aluminum

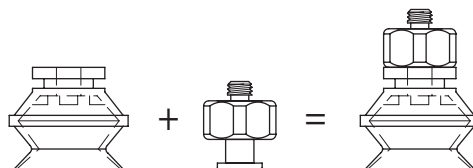

Example: Cup with Fitting

VACUUM CUP FITTINGS



Fitting Groups 5

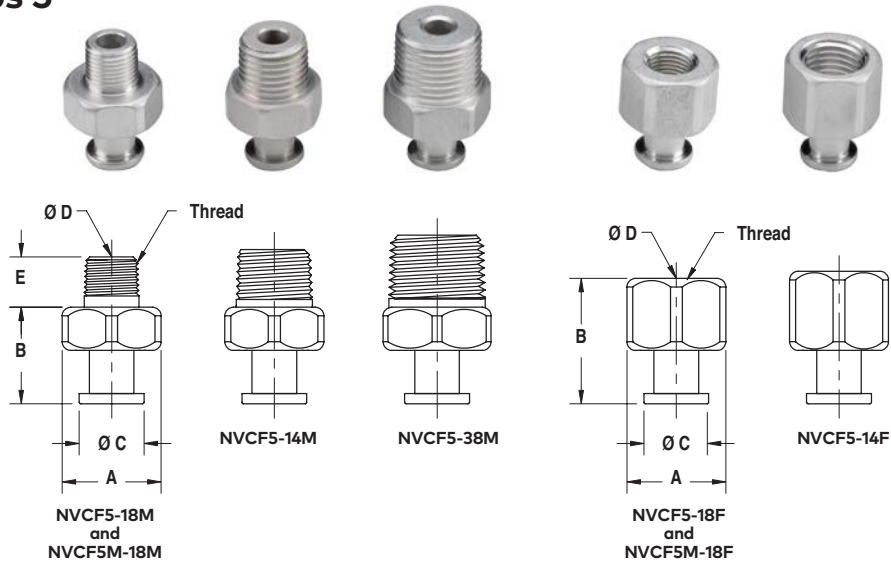

Part Number	Thread Size	Dimensions					Weight oz (g)	Material
		A-Hex in. (mm)	B in. (mm)	C in. (mm)	D Thru Hole Diameter in. (mm)	E in. (mm)		
NVCF5-18M	1/8 NPT Male	0.69 (17.4)	0.67 (17.0)	0.45 (11.4)	0.22 (5.6)	0.35 (8.9)	0.3 oz (8.5g)	Aluminum
NVCF5-14M	1/4 NPT Male	0.69 (17.4)	0.67 (17.0)	0.45 (11.4)	0.22 (5.6)	0.40 (10.2)	0.3 oz (8.5g)	Aluminum
NVCF5-38M	3/8 NPT Male	0.75 (19.1)	0.67 (17.0)	0.45 (11.4)	0.22 (5.6)	0.50 (12.7)	0.4 oz (11.0g)	Aluminum
NVCF5-18F	1/8 NPT Female	0.69 (17.4)	0.87 (22.1)	0.45 (11.4)	0.22 (5.6)	N/A	0.3 oz (8.5g)	Aluminum
NVCF5-14F	1/4 NPT Female	0.69 (17.4)	0.92 (23.4)	0.45 (11.4)	0.22 (5.6)	N/A	0.3 oz (8.5g)	Aluminum
NVCF5M-18M	G1/8 Male	0.69 (17.4)	0.87 (22.1)	0.45 (11.4)	0.22 (5.6)	0.35 (8.9)	0.3 oz (8.5g)	Aluminum
NVCF5M-18F	G1/8 Female	0.69 (17.4)	0.87 (22.1)	0.45 (11.4)	0.22 (5.6)	N/A	0.3 oz (8.5g)	Aluminum

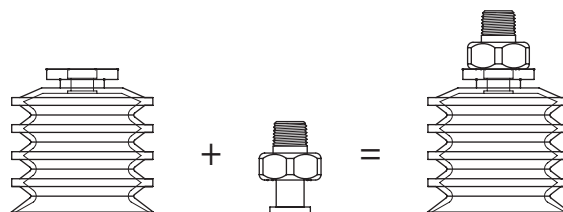

Example: Cup with Fitting

6 VACUUM CUP FITTINGS



VACUUM CUPS & FITTINGS

Fitting Groups 6

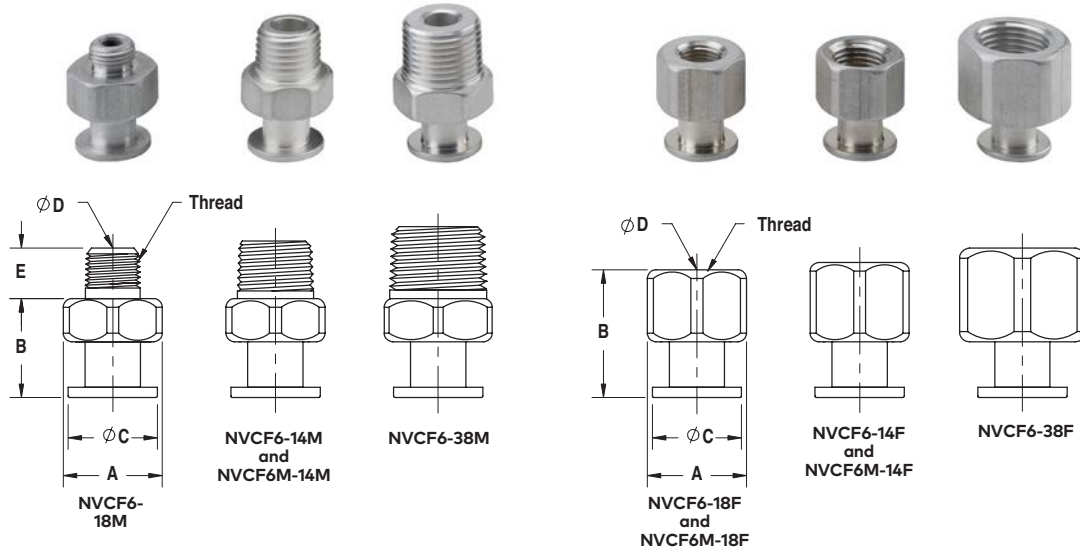

Part Number	Thread Size	Dimensions					Weight oz (g)	Material
		A-Hex in. (mm)	B in. (mm)	C in. (mm)	D Thru Hole Diameter in. (mm)	E in. (mm)		
NVCF6-18M	1/8 NPT Male	0.69 (17.4)	0.69 (17.4)	0.62 (15.7)	0.28 (7.1)	0.35 (8.9)	0.4 oz (11.0g)	Aluminum
NVCF6-14M	1/4 NPT Male	0.69 (17.4)	0.69 (17.4)	0.62 (15.7)	0.28 (7.1)	0.40 (10.2)	0.3 oz (8.5g)	Aluminum
NVCF6-38M	3/8 NPT Male	0.75 (19.1)	0.69 (17.4)	0.62 (15.7)	0.28 (7.1)	0.50 (12.7)	0.5 oz (14.0g)	Aluminum
NVCF6-18F	1/8 NPT Female	0.69 (17.4)	0.89 (22.5)	0.62 (15.7)	0.28 (7.1)	N/A N/A	0.3 oz (8.5g)	Aluminum
NVCF6-14F	1/4 NPT Female	0.69 (17.4)	0.94 (23.7)	0.62 (15.7)	0.28 (7.1)	N/A N/A	0.4 oz (11.0g)	Aluminum
NVCF6-38F	3/8 NPT Female	0.88 (22.2)	1.04 (26.3)	0.62 (15.7)	0.28 (7.1)	N/A N/A	0.4 oz (11.0g)	Aluminum
NVCF6M-14M	G 1/4 Male	0.69 (17.4)	0.69 (17.4)	0.62 (15.7)	0.28 (7.1)	0.40 (10.2)	0.3 oz (8.5g)	Aluminum
NVCF6M-14F	G 1/4 Female	0.69 (17.4)	0.94 (23.7)	0.62 (15.7)	0.28 (7.1)	N/A N/A	0.4 oz (11.0g)	Aluminum
NVCF6M-18F	G 1/8 Female	0.69 (17.4)	0.89 (22.5)	0.62 (15.7)	0.28 (7.1)	N/A N/A	0.3 oz (8.5g)	Aluminum

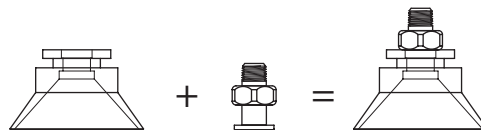

Example: Cup with Fitting

VACUUM CUP FITTINGS



Fitting Groups 7

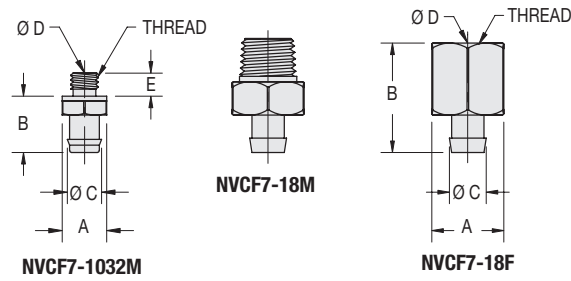

Part Number	Thread Size	Dimensions					Weight oz (g)	Material
		A-Hex in. (mm)	B in. (mm)	C in. (mm)	D Thru Hole Diameter in. (mm)	E in. (mm)		
NVCF7-1032M	10-32 Male	0.31 (7.9)	0.39 (9.9)	0.24 (6.1)	0.09 (2.4)	0.16 (4.1)	0.01 oz (0.3g)	Brass
NVCF7-18M	1/8 NPT	0.50 (12.7)	0.49 (12.4)	0.26 (6.5)	0.16 (4.1)	0.30 (7.6)	0.4 oz (11.0g)	Brass
NVCF7-18F	1/8 NPT Female	0.50 (12.7)	0.76 (19.3)	0.26 (6.5)	0.16 (4.1)	N/A	0.4 oz (11.0g)	Brass

Fitting Groups 8

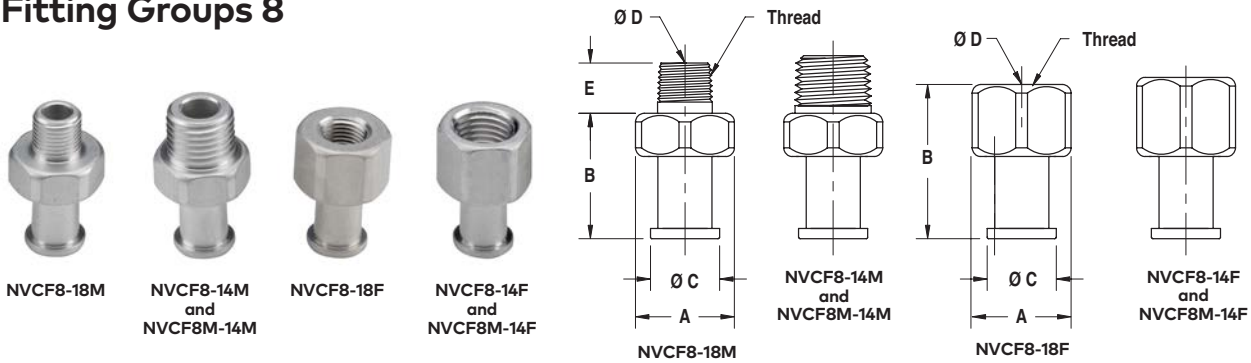

Part Number	Thread Size	Dimensions					Weight oz (g)	Material
		A-Hex in. (mm)	B in. (mm)	C in. (mm)	D Thru Hole Diameter in. (mm)	E in. (mm)		
NVCF8-18M	1/8 NPT Male	0.69 (17.4)	0.87 (22.1)	0.48 (12.2)	0.28 (7.1)	0.35 (8.9)	0.3 oz (8.5g)	Aluminum
NVCF8-14M	1/4 NPT Male	0.69 (17.4)	0.87 (22.1)	0.48 (12.2)	0.28 (7.1)	0.40 (10.2)	0.3 oz (8.5g)	Aluminum
NVCF8-18F	1/8 NPT Female	0.69 (17.4)	1.07 (27.2)	0.48 (12.2)	0.28 (7.1)	N/A	0.3 oz (8.5g)	Aluminum
NVCF8-14F	1/4 NPT Female	0.69 (17.4)	1.12 (28.4)	0.48 (12.2)	0.28 (7.1)	N/A	0.3 oz (8.5g)	Aluminum
NVCF8M-14M	G 1/4 Male	0.69 (17.4)	0.74 (18.8)	0.48 (12.2)	0.28 (7.1)	0.45 (11.4)	0.3 oz (8.5g)	Aluminum
NVCF8M-14F	G 1/4 Female	0.69 (17.4)	1.12 (28.4)	0.48 (12.2)	0.28 (7.1)	N/A	0.3 oz (8.5g)	Aluminum

6 VACUUM CUP FITTINGS



Fitting Groups 9

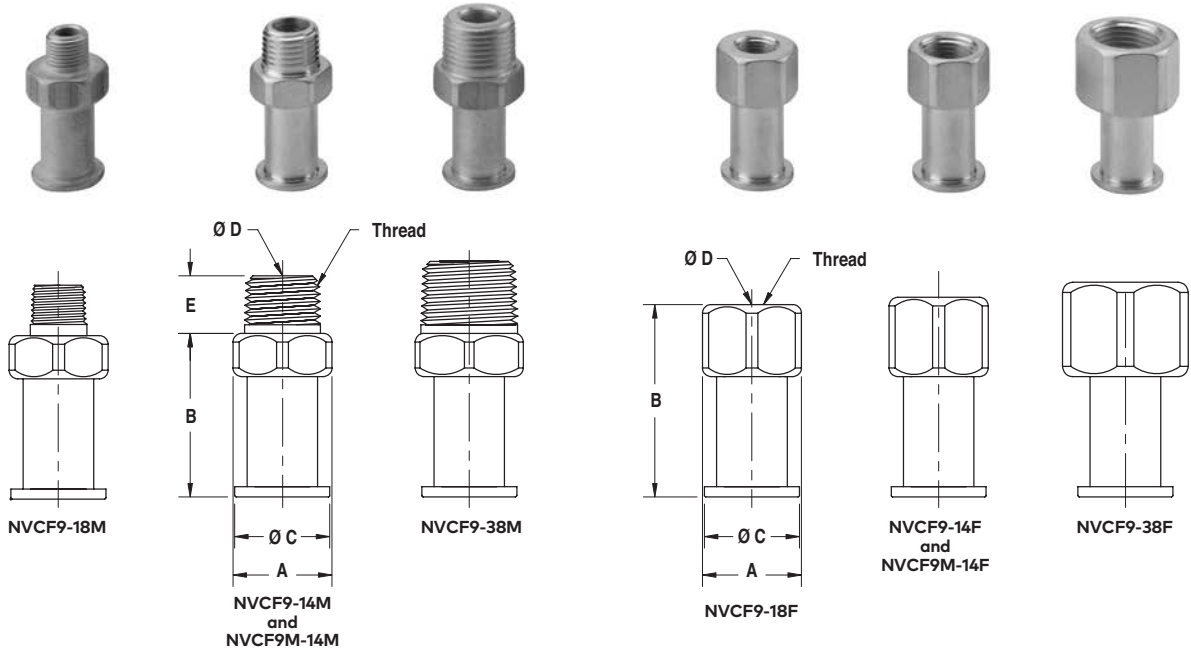

Part Number	Thread Size	Dimensions					Weight oz (g)	Material
		A-Hex in. (mm)	B in. (mm)	C in. (mm)	D Thru Hole Diameter in. (mm)	E in. (mm)		
NVCF9-18M	1/8 NPT Male	0.69 (17.4)	1.14 (28.8)	0.66 (16.8)	0.22 (5.6)	0.35 (8.9)	0.4 oz (11.0g)	Aluminum
NVCF9-14M	1/4 NPT Male	0.69 (17.4)	1.14 (28.8)	0.66 (16.8)	0.34 (8.6)	0.40 (10.2)	0.4 oz (11.0g)	Aluminum
NVCF9-38M	3/8 NPT Male	0.75 (19.1)	1.14 (28.8)	0.66 (16.8)	0.34 (8.6)	0.50 (12.7)	0.6 oz (17.0g)	Aluminum
NVCF9-18F	1/8 NPT Female	0.69 (17.4)	1.34 (33.9)	0.66 (16.8)	0.34 (8.6)	N/A	0.4 oz (11.0g)	Aluminum
NVCF9-14F	1/4 NPT Female	0.69 (17.4)	1.39 (35.2)	0.66 (16.8)	0.34 (8.6)	N/A	0.4 oz (11.0g)	Aluminum
NVCF9-38F	3/8 NPT Female	0.88 (22.4)	1.49 (37.8)	0.66 (16.8)	0.34 (8.6)	N/A	0.5 oz (14.0g)	Aluminum
NVCF9M-14M	G 1/4 Male	0.69 (17.4)	1.14 (28.8)	0.66 (16.8)	0.34 (8.6)	0.40 (10.2)	0.4 oz (11.0g)	Aluminum
NVCF9M-14F	G 1/4 Female	0.69 (17.4)	1.39 (35.2)	0.66 (16.8)	0.34 (8.6)	N/A	0.4 oz (11.0g)	Aluminum

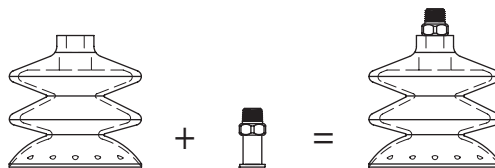

Example: Cup with Fitting

VACUUM CUP FITTINGS



Fitting Groups 11

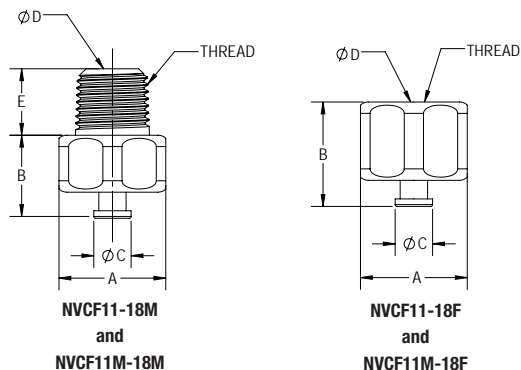

Part Number	Thread Size	Dimensions					Weight oz (g)	Material
		A-Hex in. (mm)	B in. (mm)	C in. (mm)	D Thru Hole Diameter in. (mm)	E in. (mm)		
NVCF11M-18F	G1/8 Female	0.56 (14.3)	0.55 (14.0)	0.20 (5.0)	0.05 (1.4)	N/A N/A	0.13 oz (3.6g)	Aluminum
NVCF11M-18M	G1/8 Male	0.56 (14.3)	0.44 (11.1)	0.20 (5.0)	0.05 (1.4)	0.35 (8.9)	0.18 oz (5.0g)	Aluminum
NVCF11-18F	1/8 NPT Female	0.56 (14.3)	0.55 (14.0)	0.20 (5.0)	0.05 (1.4)	N/A N/A	0.13 oz (3.6g)	Aluminum
NVCF11-18M	1/8 NPT Male	0.56 (14.3)	0.44 (11.1)	0.20 (5.0)	0.05 (1.4)	0.35 (8.9)	0.18 oz (5.0g)	Aluminum

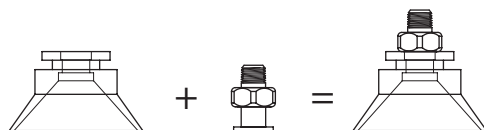

Example: Cup with Fitting



Fitting Groups 12

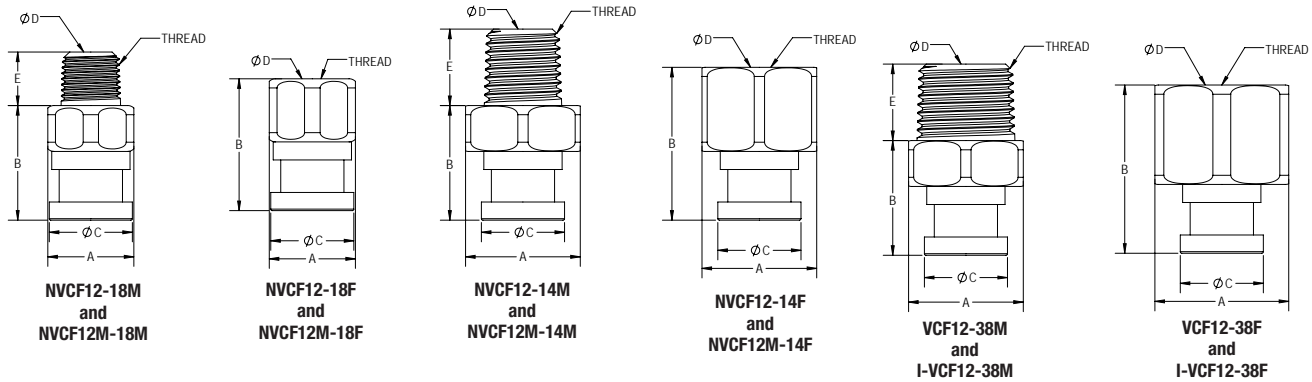

Part Number	Thread Size	Dimensions					Weight oz (g)	Material
		A-Hex in. (mm)	B in. (mm)	C in. (mm)	D Thru Hole Diameter in. (mm)	E in. (mm)		
NVCF12M-14F	G 1/4 Female	0.75 (19.1)	1.00 (25.4)	0.54 (13.8)	0.22 (5.6)	N/A N/A	0.37 oz (10.7g)	Aluminum
NVCF12M-14M	G 1/4 Male	0.75 (19.1)	0.75 (19.1)	0.54 (13.8)	0.22 (5.6)	0.5 (12.7)	0.4 oz (11.4g)	Aluminum
NVCF12M-18F	G 1/8 Female	0.56 (14.3)	0.86 (21.9)	0.54 (13.8)	0.22 (5.6)	N/A N/A	0.21 oz (6.1g)	Aluminum
NVCF12M-18M	G 1/8 Male	0.56 (14.3)	0.75 (19.1)	0.54 (13.8)	0.22 (5.6)	0.35 (8.9)	0.24 oz (6.7g)	Aluminum
NVCF12M-38F	G 3/8 Female	0.88 (22.2)	1.10 (27.9)	0.54 (13.8)	0.22 (5.6)	N/A N/A	0.51 oz (14.4g)	Aluminum
NVCF12M-38M	G 3/8 Male	0.88 (22.2)	0.75 (19.1)	0.54 (13.8)	0.22 (5.6)	0.5 (12.7)	0.49 oz (13.9g)	Aluminum
NVCF12-14F	1/4 NPT Female	0.75 (19.1)	1.00 (25.4)	0.54 (13.8)	0.28 (7.1)	N/A N/A	0.37 oz (10.6g)	Aluminum
NVCF12-14M	1/4 NPT Male	0.75 (19.1)	0.75 (19.1)	0.54 (13.8)	0.22 (5.6)	0.5 (12.7)	0.4 oz (11.4g)	Aluminum
NVCF12-18F	1/8 NPT Female	0.56 (14.3)	0.45 (11.4)	0.54 (13.8)	0.22 (5.6)	N/A N/A	0.21 oz (6.1g)	Aluminum
NVCF12-18M	1/8 NPT Male	0.56 (14.3)	0.75 (19.1)	0.54 (13.8)	0.22 (5.6)	0.35 (8.9)	0.24 oz (6.7g)	Aluminum
NVCF12-38F	3/8 NPT Female	0.88 (22.2)	1.10 (27.9)	0.54 (13.8)	0.27 (6.7)	N/A N/A	0.51 oz (14.4g)	Aluminum
NVCF12-38M	3/8 NPT Male	0.75 (19.1)	0.75 (19.1)	0.54 (13.8)	0.22 (5.6)	0.5 (12.7)	0.49 oz (13.9g)	Aluminum

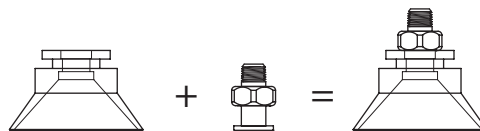

Example: Cup with Fitting

Fitting Groups 13

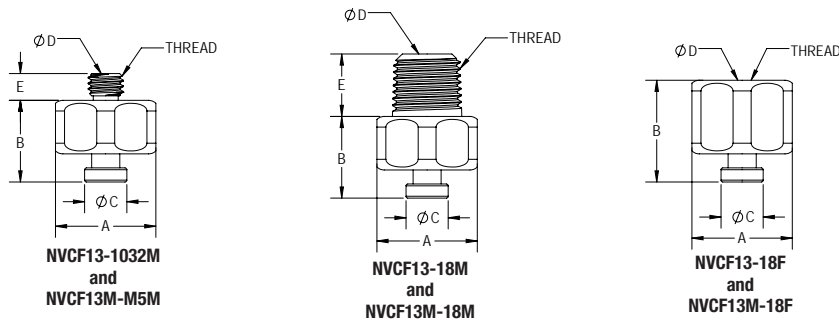

Part Number	Thread Size	Dimensions					Weight oz (g)	Material
		A-Hex in. (mm)	B in. (mm)	C in. (mm)	D Thru Hole Diameter in. (mm)	E in. (mm)		
NVCF13M-18F	G 1/8 Female	0.56 (14.3)	0.46 (11.6)	0.24 (6.0)	0.05 (1.4)	N/A N/A	0.13 oz (3.6g)	Aluminum
NVCF13M-18M	G 1/8 Male	0.56 (14.3)	0.46 (11.6)	0.24 (6.0)	0.05 (1.4)	0.35 (8.9)	0.16 oz (4.7g)	Aluminum
NVCF13M-M5M	M5x0.8 Male	0.56 (14.3)	0.46 (11.6)	0.24 (6.0)	0.05 (1.4)	0.15 (3.8)	0.13 oz (3.7g)	Aluminum
NVCF13-1032M	10-32 Male	0.56 (14.3)	0.46 (11.6)	0.24 (6.0)	0.05 (1.4)	0.15 (3.8)	0.13 oz (3.7g)	Aluminum
NVCF13-18F	1/8 NPT Female	0.56 (14.3)	0.57 (14.5)	0.24 (6.0)	0.05 (1.4)	N/A N/A	0.13 oz (3.6g)	Aluminum
NVCF13-18M	1/8 NPT Male	0.56 (14.3)	0.46 (11.6)	0.24 (6.0)	0.05 (1.4)	0.35 (8.9)	0.16 oz (4.7g)	Aluminum

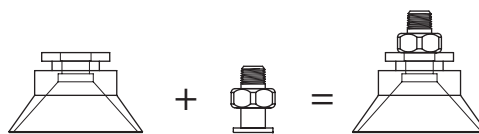

Example: Cup with Fitting



Fitting Groups 14

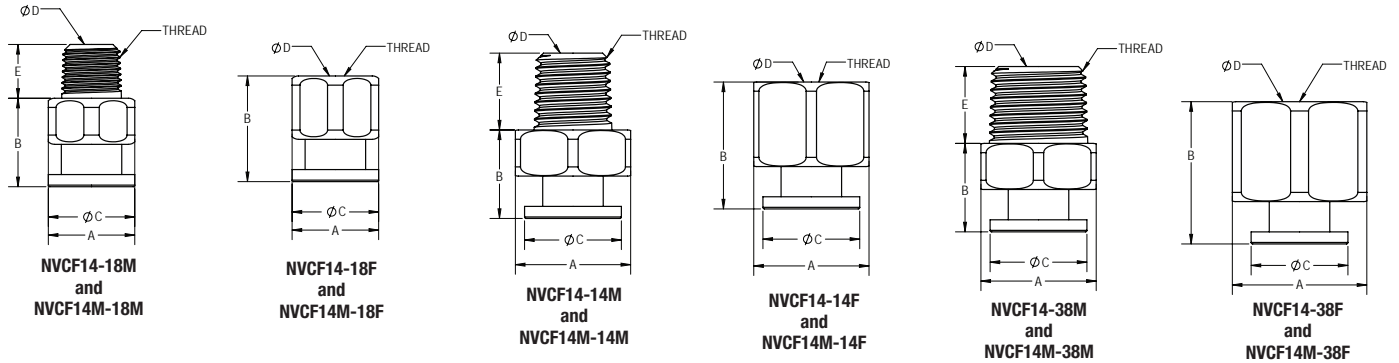

Part Number	Thread Size	Dimensions					Weight oz (g)	Material
		A-Hex in. (mm)	B in. (mm)	C in. (mm)	D Thru Hole Diameter in. (mm)	E in. (mm)		
NVCF14M-14F	G 1/4 Female	0.75 (19.1)	0.83 (21.0)	0.63 (16.0)	0.27 (6.8)	N/A N/A	0.34 oz (9.7g)	Aluminum
NVCF14M-14M	G 1/4 Male	0.75 (19.1)	0.58 (14.6)	0.63 (16.0)	0.27 (6.8)	0.5 (12.7)	0.33 oz (9.4g)	Aluminum
NVCF14M-18F	G 1/8 Female	0.56 (14.3)	0.69 (17.5)	0.63 (16.0)	0.27 (6.8)	N/A N/A	0.16 oz (4.4g)	Aluminum
NVCF14M-38F	G 3/8 Female	0.88 (22.2)	0.93 (23.5)	0.63 (16.0)	0.27 (6.8)	N/A N/A	0.48 oz (13.6g)	Aluminum
NVCF14M-38M	G 3/8 Male	0.88 (22.2)	0.58 (14.6)	0.63 (16.0)	0.27 (6.8)	0.5 (12.7)	0.42 oz (11.9g)	Aluminum
NVCF14-14F	1/4 NPT Female	0.75 (19.1)	0.83 (21.0)	0.63 (16.0)	0.27 (6.8)	N/A N/A	0.34 oz (9.7g)	Aluminum
NVCF14-14M	1/4 NPT Male	0.75 (19.1)	0.58 (14.6)	0.63 (16.0)	0.27 (6.8)	0.5 (12.7)	0.33 oz (9.4g)	Aluminum
NVCF14-18F	1/8 NPT Female	0.56 (14.3)	0.69 (17.5)	0.63 (16.0)	0.27 (6.8)	N/A N/A	0.16 oz (4.4g)	Aluminum
NVCF14-38F	3/8 NPT Female	0.88 (22.2)	0.93 (23.5)	0.63 (16.0)	0.27 (6.8)	N/A N/A	0.48 oz (13.6g)	Aluminum
NVCF14-38M	3/8 NPT Male	0.75 (19.1)	0.58 (14.6)	0.63 (16.0)	0.27 (6.8)	0.5 (12.7)	0.42 oz (11.9g)	Aluminum

VACUUM CUP FITTINGS



Fitting Groups 16

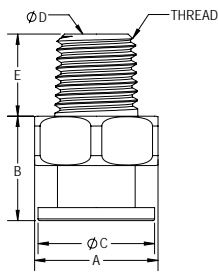

**NVCF16-14M
and
NVCF16M-14M**

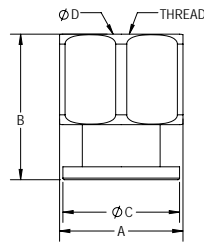

**NVCF16-14F
and
NVCF16M-14F**

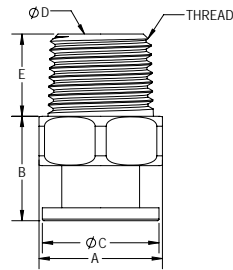

**NVCF16-38M
and
NVCF16M-38M**

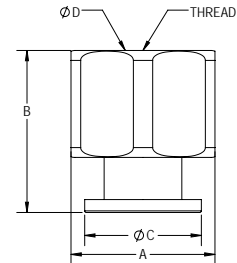

**NVCF16-38F
and
NVCF16M-38F**

Part Number	Thread Size	Dimensions					Weight oz (g)	Material
		A-Hex in. (mm)	B in. (mm)	C in. (mm)	D Thru Hole Diameter in. (mm)	E in. (mm)		
NVCF16M-14F	G 1/4 Female	0.75 (19.1)	0.89 (22.5)	0.71 (18.0)	0.35 (8.8)	N/A N/A	0.36 oz (10g)	Aluminum
NVCF16M-14M	G 1/4 Male	0.75 (19.1)	0.64 (16.1)	0.71 (18.0)	0.35 (8.8)	0.5 (12.7)	0.3 oz (8.6g)	Aluminum
NVCF16M-38F	G 3/8 Female	0.88 (22.2)	0.99 (25.0)	0.71 (18.0)	0.35 (8.8)	N/A N/A	0.49 oz (13.9g)	Aluminum
NVCF16M-38M	G 3/8 Male	0.88 (22.2)	0.64 (16.1)	0.71 (18.0)	0.35 (8.8)	0.5 (12.7)	0.39 oz (11g)	Aluminum
NVCF16-14F	1/4 NPT Female	0.75 (19.1)	0.89 (22.5)	0.71 (18.0)	0.35 (8.8)	N/A N/A	0.36 oz (10g)	Aluminum
NVCF16-14M	1/4 NPT Male	0.75 (19.1)	0.63 (16.1)	0.71 (18.0)	0.35 (8.8)	0.5 (12.7)	0.3 oz (8.6g)	Aluminum
NVCF16-38F	3/8 NPT Female	0.88 (22.2)	0.99 (25.0)	0.71 (18.0)	0.35 (8.8)	N/A N/A	0.49 oz (13.9g)	Aluminum
NVCF16-38M	3/8 NPT Male	0.75 (19.1)	0.64 (16.1)	0.71 (18.0)	0.35 (8.8)	0.5 (12.7)	0.39 oz (11g)	Aluminum

6 VACUUM CUP FITTINGS



Fitting Groups 17

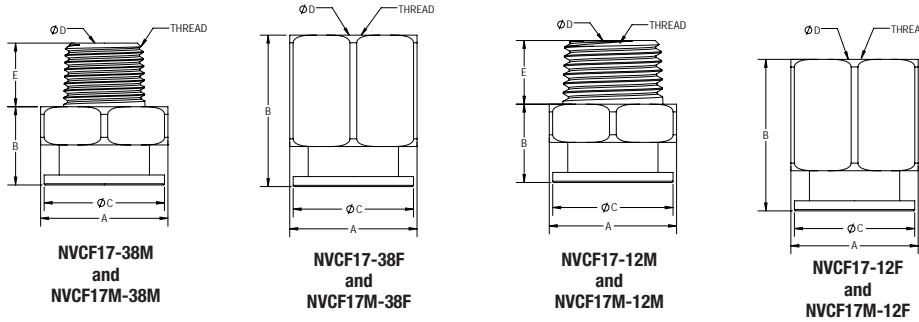

Part Number	Thread Size	Dimensions					Weight oz (g)	Material
		A-Hex in. (mm)	B in. (mm)	C in. (mm)	D Thru Hole Diameter in. (mm)	E in. (mm)		
NVCF17M-12F	G 1/2 Female	1.00 (25.4)	1.19 (30.2)	0.95 (24.0)	0.58 (14.8)	N/A N/A	0.77 oz (21.8g)	Aluminum
NVCF17M-12M	G 1/2 Male	1.00 (25.4)	0.65 (16.5)	0.95 (24.0)	0.58 (14.8)	0.5 (12.7)	0.49 oz (14g)	Aluminum
NVCF17M-38F	G 3/8 Female	0.88 (22.2)	0.97 (24.5)	0.95 (24.0)	0.58 (14.8)	N/A N/A	1.02 oz (28.8g)	Aluminum
NVCF17M-38M	G 3/8 Male	1.00 (25.4)	0.62 (15.6)	0.95 (24.0)	0.38 (9.5)	0.5 (12.7)	0.66 oz (18.6g)	Aluminum
NVCF17-38F	3/8 NPT Female	1.00 (25.4)	1.19 (30.2)	0.95 (24.0)	0.46 (11.7)	N/A N/A	1.02 oz (28.8g)	Aluminum
NVCF17-38M	3/8 NPT Male	1.00 (25.4)	0.62 (15.6)	0.95 (24.0)	0.38 (9.5)	0.5 (12.7)	0.66 oz (18.6g)	Aluminum
NVCF17-12F	1/2 NPT Female	1.00 (25.4)	1.19 (30.2)	0.95 (24.0)	0.58 (14.8)	N/A N/A	0.77 oz (21.8g)	Aluminum
NVCF17-38M	1/2 NPT Male	1.00 (25.4)	0.62 (15.6)	0.95 (24.0)	0.58 (14.8)	0.5 (12.7)	0.66 oz (18.8g)	Aluminum

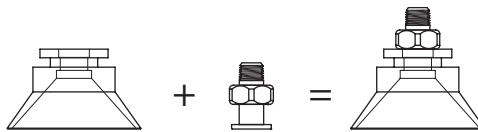

Example: Cup with Fitting

VACUUM CUP FITTINGS



Fitting Groups 19

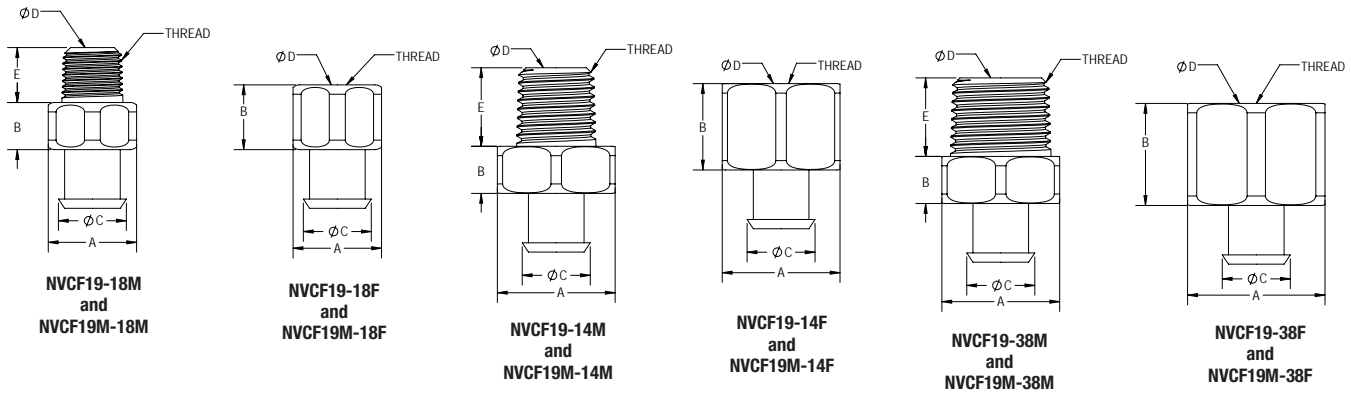

Part Number	Thread Size	Dimensions					Weight oz (g)	Material
		A-Hex in. (mm)	B in. (mm)	C in. (mm)	D Thru Hole Diameter in. (mm)	E in. (mm)		
NVCF19M-14F	G 1/4 Female	0.75 (19.1)	0.92 (23.5)	0.43 (11.0)	0.23 (5.8)	N/A N/A	0.33 oz (9.4g)	Aluminum
NVCF19M-14M	G 1/4 Male	0.75 (19.1)	0.67 (17.1)	0.43 (11.0)	0.23 (5.8)	0.5 (12.7)	0.37 oz (9.6g)	Aluminum
NVCF19M-18F	G 1/8 Female	0.56 (14.3)	0.79 (20.0)	0.43 (11.0)	0.23 (5.8)	N/A N/A	0.15 oz (4.3g)	Aluminum
NVCF19M-18M	G 1/8 Male	0.56 (14.3)	0.67 (17.1)	0.43 (11.0)	0.23 (5.8)	0.35 (8.9)	0.17 oz (4.8g)	Aluminum
NVCF19M-38F	G 3/8 Female	0.88 (22.2)	1.02 (26.0)	0.43 (11.0)	0.23 (5.8)	N/A N/A	0.46 oz (13g)	Aluminum
NVCF19M-38M	G 3/8 Male	0.88 (22.2)	1.17 (29.8)	0.43 (11.0)	0.23 (5.8)	0.5 (12.7)	0.42 oz (12g)	Aluminum
NVCF19-14F	1/4 NPT Female	0.75 (19.1)	0.92 (23.5)	0.43 (11.0)	0.23 (5.8)	N/A N/A	0.33 oz (94g)	Aluminum
NVCF19-14M	1/4 NPT Male	0.75 (19.1)	0.67 (17.1)	0.43 (11.0)	0.23 (5.8)	0.5 (12.7)	0.34 oz (9.6g)	Aluminum
NVCF19-18F	1/8 NPT Male	0.56 (14.3)	0.79 (20.0)	0.43 (11.0)	0.23 (5.8)	N/A N/A	0.15 oz (4.3g)	Aluminum
NVCF19-18M	1/8 NPT Male	0.56 (14.3)	0.67 (17.1)	0.43 (11.0)	0.23 (5.8)	0.35 (8.9)	0.17 oz (4.8g)	Aluminum
NVCF19-38F	3/8 NPT Male	0.88 (22.2)	1.02 (26.0)	0.43 (11.0)	0.23 (5.8)	N/A N/A	0.46 oz (13.0g)	Aluminum
NVCF19-38M	3/8 NPT Male	0.75 (19.1)	0.67 (17.1)	0.43 (11.0)	0.23 (5.8)	0.5 (12.7)	0.42 oz (11.9g)	Aluminum

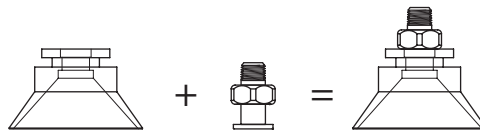

Example: Cup with Fitting

6 VACUUM CUP FITTINGS



Fitting Groups 22

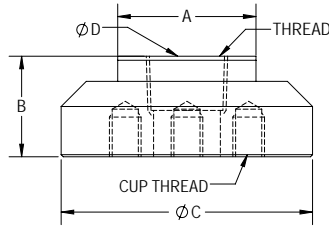

Part Number	Thread Size	Dimensions					Weight oz (g)	Material
		A-Hex in. (mm)	B in. (mm)	C in. (mm)	D Thru Hole Diameter in. (mm)	E in. (mm)		
NVCF22M-14F	G 1/4 Female	0.69 (17.5)	0.50 (12.7)	1.25 (31.8)	0.45 (11.5)	N/A N/A	0.6 oz (17g)	Aluminum
NVCF22M-18F	G 1/8 Female	0.69 (17.5)	0.50 (12.7)	1.25 (31.8)	0.34 (8.7)	N/A N/A	0.67 oz (19g)	Aluminum
NVCF22-14F	1/4 NPT Female	0.75 (19.1)	0.50 (12.7)	1.25 (31.8)	0.44 (11.1)	N/A N/A	0.6 oz (17g)	Aluminum
NVCF22-18F	1/8 NPT Female	0.75 (19.1)	0.50 (12.7)	1.25 (31.8)	0.33 (8.4)	N/A N/A	0.67 oz (19g)	Aluminum

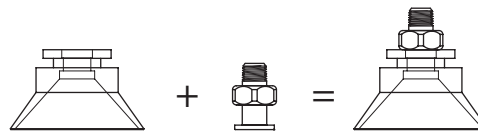

Example: Cup with Fitting

VACUUM CUP FITTINGS



Fitting Groups 23

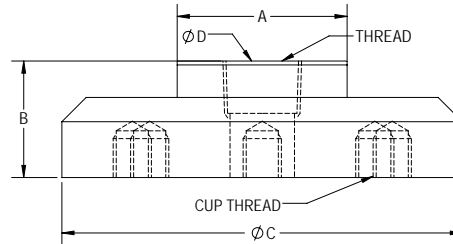

Part Number	Thread Size	Dimensions					Weight oz (g)	Material
		A-Hex in. (mm)	B in. (mm)	C in. (mm)	D Thru Hole Diameter in. (mm)	E in. (mm)		
NVCF23M-14F	G 1/4 Female	0.88 (22.2)	0.60 (15.2)	2.06 (52.4)	0.47 (11.8)	N/A N/A	2.08 oz (59g)	Aluminum
NVCF23M-18F	G 1/8 Female	0.88 (22.2)	0.60 (15.2)	2.06 (52.4)	0.35 (8.8)	N/A N/A	2.15 oz (61g)	Aluminum
NVCF23M-38F	G 3/8 Female	0.88 (22.2)	0.60 (15.2)	2.06 (52.4)	0.60 (15.2)	N/A N/A	1.98 oz (56g)	Aluminum
NVCF23-14F	1/4 NPT Female	0.88 (22.2)	0.60 (15.2)	2.06 (52.4)	0.44 (11.1)	N/A N/A	2.08 oz (59g)	Aluminum
NVCF23-18F	1/8 NPT Female	0.88 (22.2)	0.60 (15.2)	2.06 (52.4)	0.33 (8.4)	N/A N/A	2.15 oz (61g)	Aluminum
NVCF23-38F	3/8 NPT Female	0.88 (22.2)	0.60 (15.2)	2.06 (52.4)	0.56 (14.3)	N/A N/A	1.98 oz (56g)	Aluminum

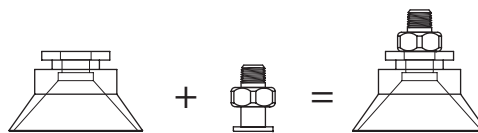

Example: Cup with Fitting

6 VACUUM CUP FITTINGS



Fitting Groups 24

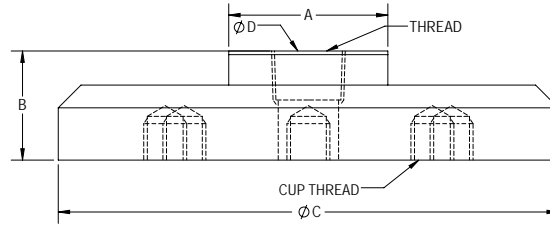

Part Number	Thread Size	Dimensions					Weight oz (g)	Material
		A-Hex in. (mm)	B in. (mm)	C in. (mm)	D Thru Hole Diameter in. (mm)	E in. (mm)		
NVCF24M-14F	G 1/4 Female	0.88 (22.2)	0.60 (15.2)	2.75 (69.9)	0.47 (11.8)	N/A N/A	3.71 oz (105.5g)	Aluminum
NVCF24M-18F	G 1/8 Female	0.88 (22.2)	0.60 (15.2)	2.75 (69.9)	0.35 (8.8)	N/A N/A	3.78 oz (107.2g)	Aluminum
NVCF24M-38F	G 3/8 Female	0.88 (22.2)	0.60 (15.2)	2.75 (69.9)	0.60 (15.2)	N/A N/A	3.6 oz (102.1g)	Aluminum
NVCF24-14F	1/4 NPT Female	0.88 (22.2)	0.60 (15.2)	2.75 (69.9)	0.44 (11.1)	N/A N/A	3.71 oz (105.5g)	Aluminum
NVCF24-18F	1/8 NPT Female	0.88 (22.2)	0.60 (15.2)	2.75 (69.9)	0.33 (8.4)	N/A N/A	3.78 oz (107.2g)	Aluminum
NVCF24-38F	3/8 NPT Female	0.88 (22.2)	0.60 (15.2)	2.75 (69.9)	0.56 (14.3)	N/A N/A	3.6 oz (102.1g)	Aluminum

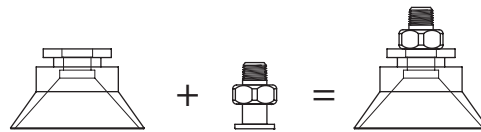

Example: Cup with Fitting

VACUUM CUP FITTINGS



Fitting Groups 25

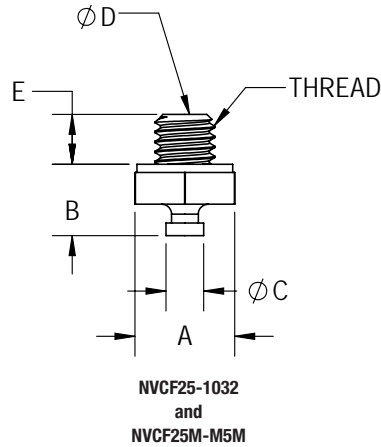

Part Number	Thread Size	Dimensions					Weight oz (g)	Material
		A-Hex in. (mm)	B in. (mm)	C in. (mm)	D Thru Hole Diameter in. (mm)	E in. (mm)		
NVCF25-1032	10-32 Male	0.31 (8.0)	0.20 (5.1)	0.12 (3.0)	0.05 (1.2)	0.182 (4.6)	0.07 oz (1.9g)	Aluminum
NVCF25M-M5M	M5 Male	0.31 (8.0)	0.20 (5.1)	0.12 (3.0)	0.05 (1.2)	0.182 (4.6)	0.07 oz (1.9g)	Aluminum

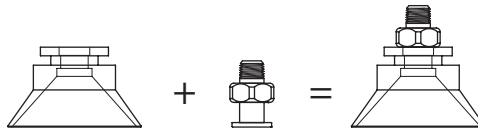

Example: Cup with Fitting

6 VACUUM CUP FITTINGS



Fitting Groups 26

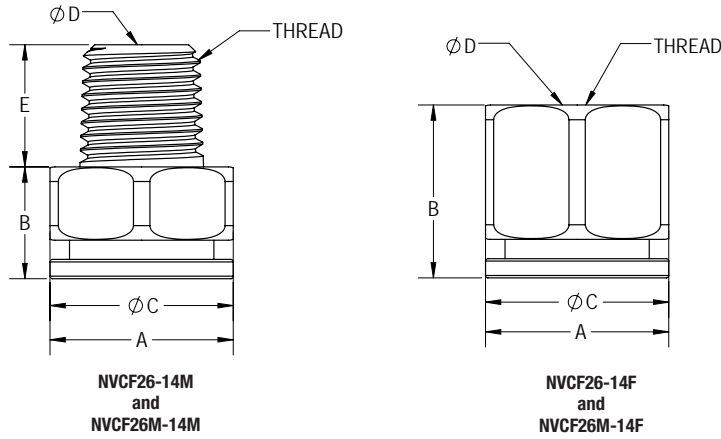

Part Number	Thread Size	Dimensions					Weight oz (g)	Material
		A-Hex in. (mm)	B in. (mm)	C in. (mm)	D Thru Hole Diameter in. (mm)	E in. (mm)		
NVCF26-14F	1/4 NPT Female	0.75 (19.1)	0.71 (18.0)	0.76 (19.3)	0.28 (7.1)	N/A N/A	0.36 oz (10.3g)	Aluminum
NVCF26-14M	1/4 NPT Male	0.75 (19.1)	0.46 (11.6)	0.76 (19.3)	0.22 (5.6)	0.5 (12.7)	0.38 oz (10.8g.)	Aluminum
NVCF26M-14M	G 1/4 Male	0.75 (19.1)	0.46 (11.6)	0.76 (19.3)	0.22 (5.6)	0.5 (12.7)	0.38 oz (10.8g)	Aluminum
NVCF26M-14F	G 1/4 Female	0.75 (19.1)	0.71 (18.0)	0.76 (19.3)	0.22 (5.6)	N/A N/A	0.36 oz (10.3g)	Aluminum

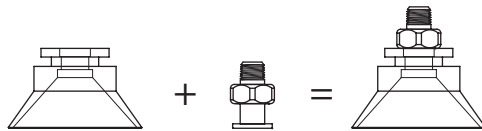

Example: Cup with Fitting

VACUUM CUP FITTINGS



Fitting Groups 27

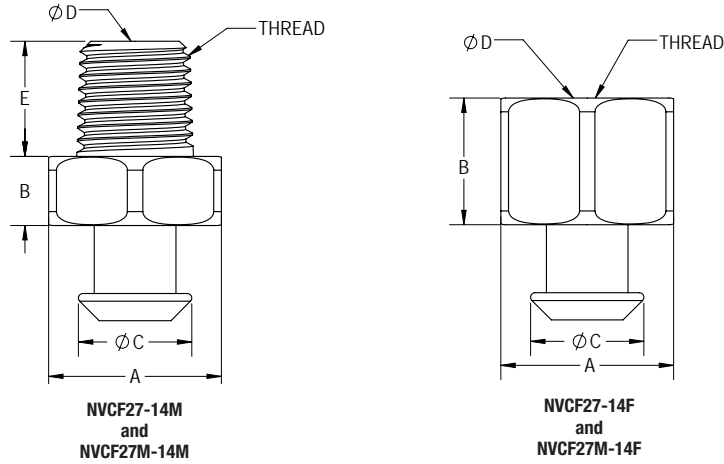

Part Number	Thread Size	Dimensions					Weight oz (g)	Material
		A-Hex in. (mm)	B in. (mm)	C in. (mm)	D Thru Hole Diameter in. (mm)	E in. (mm)		
NVCF27-14F	1/4 NPT Female	0.75 (19.1)	0.96 (24.5)	0.49 (12.5)	0.25 (6.4)	N/A N/A	0.33 oz (9.4g)	Aluminum
NVCF27-14M	1/4 NPT Male	0.75 (19.1)	0.71 (23.6)	0.49 (10.9)	0.25 (5.6)	0.5 (12.7)	0.33 oz (9.4g)	Aluminum
NVCF27M-14F	G 1/4 Female	0.75 (19.1)	0.96 (24.5)	0.49 (12.5)	0.25 (6.4)	N/A N/A	0.33 oz (9.4g)	Aluminum
NVCF27M-14M	G 1/4 Male	0.75 (19.1)	0.71 (18.1)	0.49 (12.5)	0.25 (6.4)	0.5 (12.7)	0.33 oz (9.4g)	Aluminum

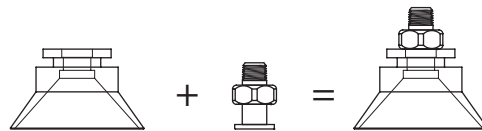

Example: Cup with Fitting

6 VACUUM CUP FITTINGS



Fitting Groups 28

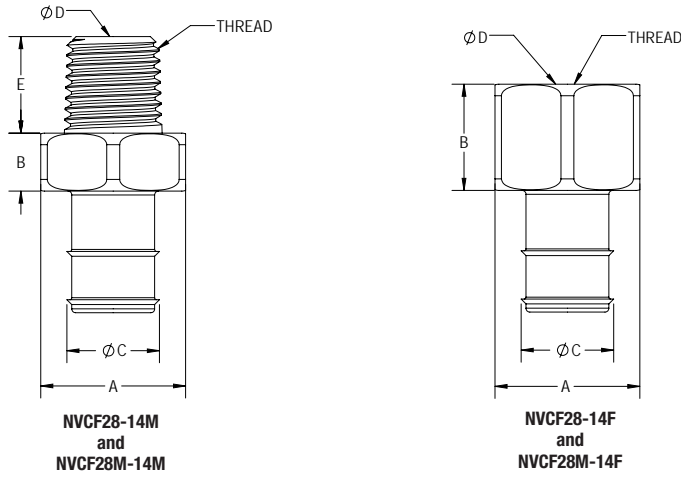

Part Number	Thread Size	Dimensions					Weight oz (g)	Material
		A-Hex in. (mm)	B in. (mm)	C in. (mm)	D Thru Hole Diameter in. (mm)	E in. (mm)		
NVCF28-14F	1/4 NPT Female	0.75 (19.1)	1.18 (30.0)	0.43 (10.9)	0.22 (5.6)	N/A N/A	0.40 oz (11.3g)	Aluminum
NVCF28-14M	1/4 NPT Male	0.75 (19.1)	0.93 (23.6)	0.43 (10.9)	0.22 (5.6)	0.5 (12.7)	0.41 oz (11.6g)	Aluminum
NVCF28M-14F	G 1/4 Female	0.75 (19.1)	1.18 (30.0)	0.43 (10.9)	0.22 (5.6)	N/A N/A	0.41 oz (11.6g)	Aluminum
NVCF28M-14M	G 1/4 Male	0.75 (19.1)	0.93 (23.6)	0.43 (10.9)	0.22 (5.6)	0.142 (3.6)	0.41 oz (11.6g)	Aluminum

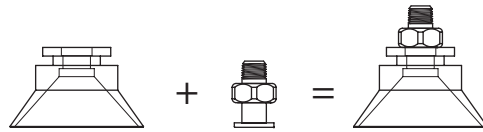

Example: Cup with Fitting

PUSH-IN-FITTINGS

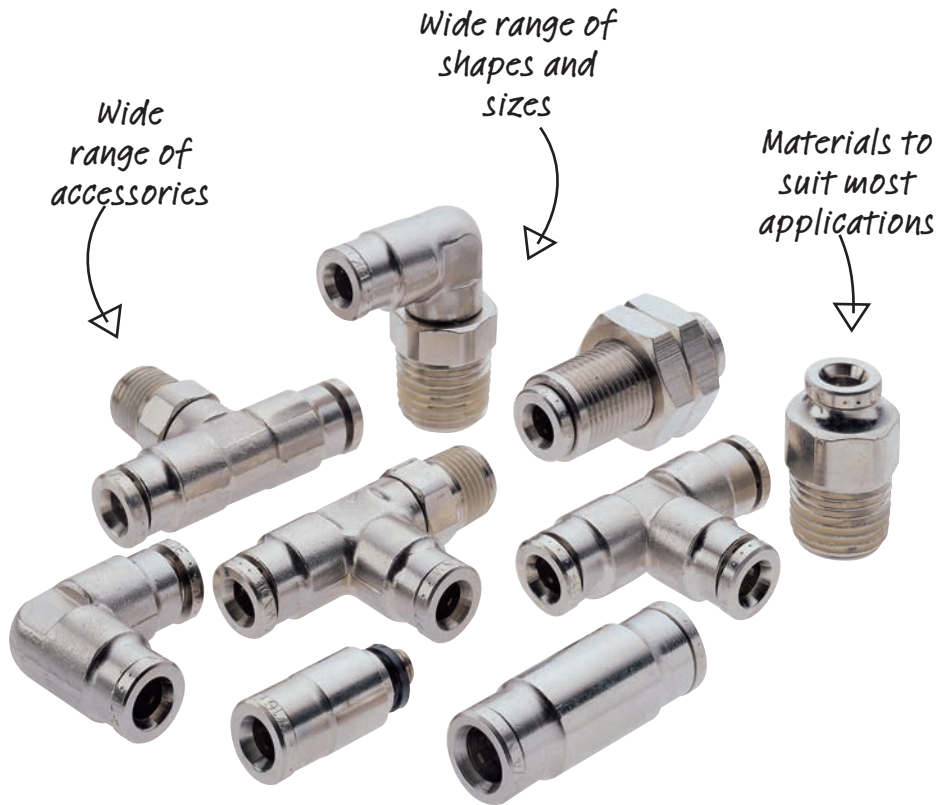

Precision Engineering offers one of the most comprehensive ranges of pneumatic fittings in the industry. Selecting the right fitting is critical to the application.

PNEUFIT® PUSH-IN FITTINGS

Inch Ø 1/8" to 1/2" O/D tube



- » For simple and quick assembly of pneumatic circuits.
- » Positive tube connection.
- » Wide range of types available.
- » Reliable and corrosion resistant.

Technical Data

Fluid:

Compressed air, nitrogen, inert and non-combustible gases compatible with materials of construction.

Note: For other types of fluids or compressed gases, please consult factory.

Working Pressure:

29.5" Hg vacuum to 260 psig (750 mm Hg to 18 bar)

Note: Flow Control working pressures:
5 to 150 psig (.3 to 10 bar)

Working Temperature:

-4° to 175°F (-20° to 80°C)

Materials

Body, swivel fitting and collet: Nickel plated brass

O-ring: Silicone free Nitrile

Sealing washer (parallel male threads): silicone free nitrile

Tubing: Nylon 11 or 12, Polyurethane (95 durometer or above) and LDPE (Low Density Polyethylene).

Note: Lower durometer polyurethane may be used, however, an internal tube support is required to prevent internal collapse of the tube wall.

Thread Sealant: Precote 5
Thread sealant is factory applied to the circumference of tapered male threads.



Recommended tightening torques

NPT or UNF Thread	Tightening torque ft lbs (Nm)
10-32 UNF	0.75 - 1 (1-1.4)
1/8"	5.0 - 6.5 (6.9 - 8.8)
1/4"	8.7 - 10.1 (11.8 - 13.7)
3/8"	15.9 - 17.3 (21.6 - 23.5)
1/2"	20.2 - 21.7 (27.4 - 29.4)

Tube O.D.'s and tube tolerances

Tube O.D.	O.D. Tube Tolerances	
	Nylon	Polyurethane
1/8" to 1/2"	+0.002" (+0.05 mm)	±0.005" (±0.12)

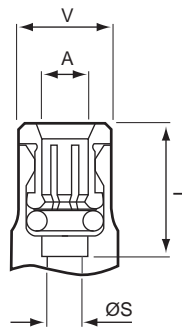
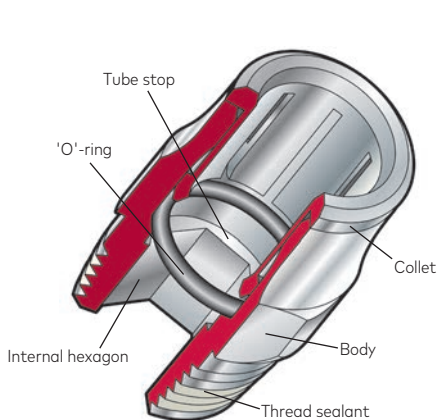

Dimensions inches (mm)

A O.D. Tube	S	T	V
1/8"	0.09 (2.3)	0.53 (13.5)	0.26 (6.6)
5/32" (4)	0.11 (2.8)	0.55 (14.1)	0.30 (7.6)
3/16"	0.13 (3.4)	0.59 (15.1)	0.38 (9.7)
1/4"	0.17 (4.3)	0.61 (15.5)	0.42 (10.7)
5/16"	0.24 (4.4)	0.65 (16.5)	0.51 (13.1)
3/8"	0.30 (7.6)	0.83 (21.1)	0.59 (15.1)
1/2"	0.38 (9.7)	0.96 (24.4)	0.71 (18.0)

PNEUFIT® PUSH-IN FITTINGS

Inch Ø 1/8" to 1/2" O/D tube

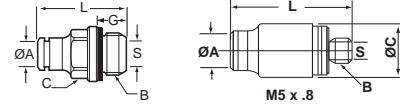
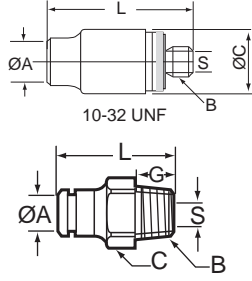

Pneufit® Male Adapter

Part Number	A Tube O.D.	B NPT or UNF Thread	C A/F	G	L	S Hex
124250110	1/8"	10-32 UNF	0.35	0.20	0.79	3/32"
124250116	1/8"	1/16	3/8"	0.37	0.80	3/32"
124250118	1/8"	1/8	7/16"	0.37	0.67	3/32"
124250128	1/8"	1/4	9/16"	0.56	0.95	3/32"
124250210	5/32"	10-32 UNF	0.35	0.20	0.85	3/32"
124250218	5/32"	1/8	7/16"	0.37	0.89	1/8"
124250228	5/32"	1/4	9/16"	0.56	1.04	1/8"
124250318	3/16"	1/8	7/16"	0.37	0.96	5/32"
124250328	3/16"	1/4	9/16"	0.56	1.04	5/32"
124250410	1/4"	10-32 UNF	0.43	0.20	0.94	3/32"
124250418	1/4"	1/8	7/16"	0.37	0.98	5/32"
124250428	1/4"	1/4	9/16"	0.56	1.11	5/32"
124250438	1/4"	3/8	11/16"	0.56	1.07	3/16"
124250518	5/16"	1/8	1/2"	0.37	1.12	3/16"
124250528	5/16"	1/4	9/16"	0.56	1.23	1/4"
124250538	5/16"	3/8	11/16"	0.56	1.13	1/4"
124250618	3/8"	1/8	11/16"	0.37	1.32	3/16"
124250628	3/8"	1/4	11/16"	0.56	1.47	1/4"
124250638	3/8"	3/8	11/16"	0.56	1.41	5/16"
124250648	3/8"	1/2	7/8"	0.75	1.45	5/16"
124250728	1/2"	1/4	7/8"	0.56	1.67	1/4"
124250738	1/2"	3/8	7/8"	0.56	1.63	3/8"
124250748	1/2"	1/2	7/8"	0.75	1.70	3/8"

Pneufit® ISO G Male Adapter

Part number	A Ø tube	B ISO G or Metric thread	C A/F	G	L	S Hex
102250405	4	M5 x .8	9.0 Ø	5.0	21.9	2.5
102250418	4	1/8	10	7.2	23.0	3.0
102250605	6	M5 x .8	11.0 Ø	5.0	23.7	2.5
102250628	6	1/4	13	9.8	23.7	4.0
102250818	8	1/8	13	7.2	26.7	5.0
102250828	8	1/4	14	9.8	28.2	6.0
102251028	10	1/4	17	9.8	33.7	7.0

Pneufit® ISO G Male Connector



All straight male connectors have an internal hex for the use of an Allen Wrench to allow the fitting to be mounted in any position. This also permits close porting not possible with a standard open end or socket wrench.

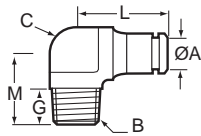

Pneufit® Fixed Male Elbow

Part Number	A Tube O.D.	B NPT Thread	C A/F	G	L	M
124450118	1/8"	1/8	0.28	0.37	0.67	0.66
124450218	5/32"	1/8	0.28	0.37	0.67	0.66
124450228	5/32"	1/4	0.43	0.56	0.72	0.92
124450318	3/16"	1/8	0.28	0.37	0.72	0.67
124450328	3/16"	1/4	0.43	0.56	0.79	0.92
124450418	1/4"	1/8	0.31	0.37	0.77	0.70
124450428	1/4"	1/4	0.43	0.56	0.79	0.92
124450438	1/4"	3/8	0.63	0.56	0.84	1.1
124450518	5/16"	1/8	0.43	0.37	0.84	0.74
124450528	5/16"	1/4	0.43	0.56	0.84	0.92
124450618	3/8"	1/8	0.52	0.37	1.05	0.8
124450628	3/8"	1/4	0.52	0.56	1.05	0.98
124450638	3/8"	3/8	0.63	0.56	1.05	1.1
124450648	3/8"	1/2	0.94	0.75	1.13	1.36
124450728	1/2"	1/4	0.63	0.56	1.25	1.03
124450738	1/2"	3/8	0.63	0.56	1.25	1.1
124450748	1/2"	1/2	0.94	0.75	1.25	1.36

PNEUFIT® PUSH-IN FITTINGS

Inch Ø 1/8" to 1/2" O/D tube

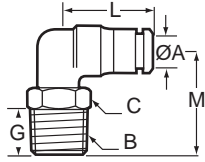

Pneufit® Swivel Male Elbow

Part Number	A Tube O.D.	B NPT or UNF Thrd	C A/F	G	L	M
124470110	1/8"	10-32 UNF	5/16"	0.20	0.63	0.70
124470118	1/8"	1/8	7/16"	0.37	0.63	0.82
124470128	1/8"	1/4	9/16"	0.37	0.68	1.07
124470210	5/32"	10-32 UNF	5/16"	0.20	0.67	0.70
124470218	5/32"	1/8	7/16"	0.37	0.67	0.86
124470228	5/32"	1/4	9/16"	0.56	0.67	1.07
124470328	3/16"	1/4	9/16"	0.56	0.72	1.09
124470410	1/4"	10-32 UNF	5/16"	0.20	0.77	0.71
124470418	1/4"	1/8	7/16"	0.37	0.77	0.9
124470428	1/4"	1/4	9/16"	0.56	0.77	1.11
124470438	1/4"	3/8	3/4"	0.56	0.8	1.15
124470518	5/16"	1/8	9/16"	0.37	0.84	0.96
124470528	5/16"	1/4	9/16"	0.56	0.84	1.15
124470618	3/8"	1/8	9/16"	0.37	1.05	1.05
124470628	3/8"	1/4	11/16"	0.56	1.05	1.26
124470638	3/8"	3/8	3/4"	0.56	1.05	1.26
124470648	3/8"	1/2	7/8"	0.75	1.05	1.48
124470728	1/2"	1/4	3/4"	0.56	1.25	1.37
124470738	1/2"	3/8	3/4"	0.56	1.25	1.41
124470748	1/2"	1/2	7/8"	0.75	1.25	1.62

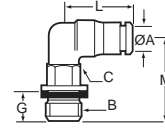

Pneufit® ISO R Swivel Male Elbow

Part number	A O/D tube	B ISO R thread	C A/F	G	L	M
101470418	4	1/8	10	7.7	16.9	20.5
101470628	6	1/4	4	11.1	19.6	25.1
101470818	8	1/8	14	7.7	21.3	23.0
101470828	8	1/4	14	11.1	21.3	26.1
101471028	10	1/4	17	11.1	26.7	28.8
101471038	10	3/8	17	12.7	26.7	30.5

CAUTION: Swivel adapters are not suitable for use in continuously rotating or gyrating applications.

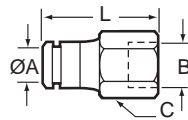

Pneufit® Female Adapter

Part Number	A Tube O.D.	B NPT Thread	C A/F	L
124260118	1/8"	1/8	9/16"	1.14
124260128	1/8"	1/4	11/16"	1.38
124260218	5/32"	1/8	9/16"	1.14
124260228	5/32"	1/4	11/16"	1.42
124260418	1/4"	1/8	9/16"	1.19
124260428	1/4"	1/4	11/16"	1.46
124260518	5/16"	1/8	9/16"	1.23
124260528	5/16"	1/4	11/16"	1.50
124260628	3/8"	1/4	11/16"	1.66
124260638	3/8"	3/8	7/8"	1.70

[End-of-Arm Tooling]



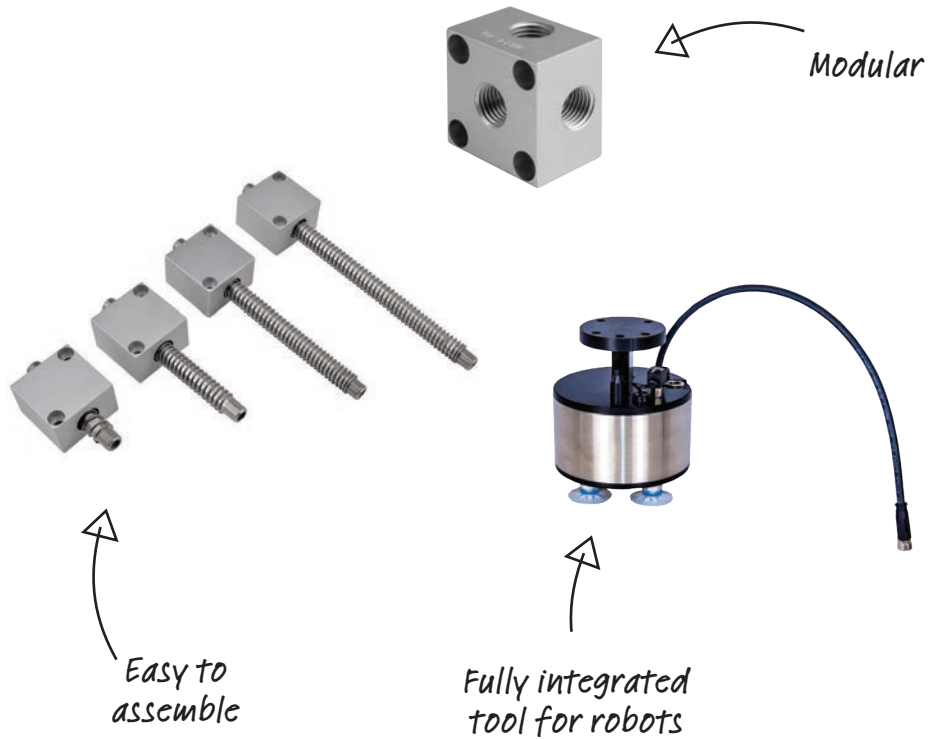

Norgren offers a complete range of easy to assemble, modular end-of-arm tooling components and fully configured solutions.





Please note: These products represent only part of the Norgren vacuum range.
If you can't see the option you require please contact us.

End-of-Arm Tooling

<p>NCRVT Fully integrated vacuum tool designed for collaborative robots</p>  <p>Page 205</p>	<p>Spring Levelers Mechanical compensation for uneven surfaces</p>  <p>Page 207</p>	<p>Mounting Brackets To connect spring levelers to vacuum generators</p>  <p>Page 222</p>	<p>Manifold Blocks For mounting vacuum cups to extrusions and/or distributing vacuum to multiple locations</p>  <p>Page 227</p>
--	---	---	---

- » Plug and play operation:
Just simply add air
- » Mounting plate is designed for specific robot brand
- » Adjustable vacuum switch for part detection
- » Pre-installed muffler for quiet operation
- » Integrated valve simplifies installation
- » Mounting hardware included

Technical Data

Stocked configurations:

NCRVTU-150M-P-C** for semi-porous applications
NCRVTU-100H-P-C** for non-porous applications

Consult factory for assistance choosing the correct vacuum characteristics for your applications

Standard vacuum ports:

(1) 1/4" NPT female
(4) 1/8" NPT female
Consult factory for custom options



Option selector

Series	Substitute	NCRVT	-C	Cup Configuration	Substitute
NCRVT (Norgren Collaborative Robot Vacuum Tool)				No Cups	C01
Robot Type	Substitute			Single cup, dual durometer, polyurethane, single bellows	C02
Universal Robots	U			Quad cup, dual durometer, polyurethane, single bellows	C03
Vacuum Flow Level	Substitute			Single cup, silicone, flat	C04
Venturi Cartridge 60	060			Quad cup, silicone, flat	C05
Venturi Cartridge 90	090			Switch / Sensor	Substitute
Venturi Cartridge 100	100			Switch (PNP)	P
Venturi Cartridge 150	150			Sensor (1-5V DC outlet)	S
Vacuum Level	Substitute				
10"Hg @ 80PSI (Standard)	L				
20"Hg @ 80PSI (Standard)	M				
28"Hg @ 80PSI (Standard)	H				
10"Hg @ 60PSI	X				
20"Hg @ 60PSI	Y				
28"Hg @ 60PSI	Z				

Dimensions inches (mm)

Vacuum Port Layout

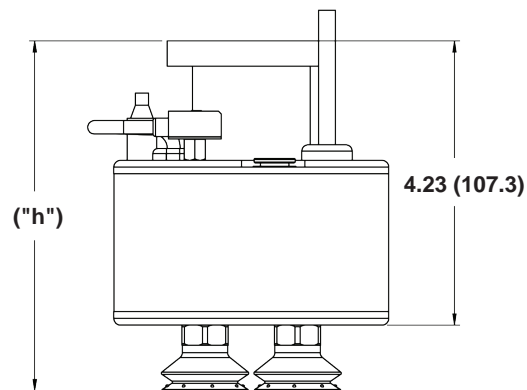
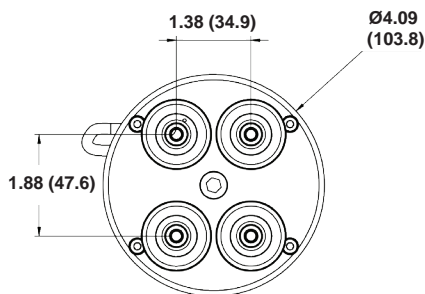

	Height "h" (mm)	Weight lb (kg)
C01	4.23 (107.3)	1.90 (0.86)
C02	5.67 (144.1)	2.00 (0.91)
C03	5.20 (132.0)	2.10 (0.95)
C04	5.78 (146.8)	2.10 (0.95)
C05	4.92 (125.0)	2.00 (0.91)



Operating Ranges

Temperature ranges for normal operation of end effector.

Cup	Working temperature
C01	14° F to 140° F (-10° C to 60° C)
C02	50° F to 122° F (10° C to 50° C)
C03	50° F to 122° F (10° C to 50° C)
C04	14° F to 140° F (-10° C to 60° C)
C05	14° F to 140° F (-10° C to 60° C)

Performance Data

	Air consumption (scfm [slpm])		
	L 10" Hg (339 mbar)	M 20" Hg (677 mbar)	H 28" Hg (948 mbar)
060	N/A	0.50 (14.2)	0.80 (22.6)
090	0.50 (14.2)	1.40 (39.6)	1.80 (51.0)
100	1.40 (39.6)	1.80 (51.0)	2.80 (79.3)
150	1.80 (51.0)	2.80 (79.3)	4.80 (135.9)

	Approximate time to reach full vacuum (seconds) ⁵		
	L 10" Hg (339 mbar)	M 20" Hg (677 mbar)	H 28" Hg (948 mbar)
060	N/A	1.2	4.2
090	0.2	0.6	1.5
100	0.1	0.3	1.3
150	0.1	0.3	0.7

	Maximum recommended load (lb [kg]) ¹		
	L 10" Hg (339 mbar)	M 20" Hg (677 mbar)	H 28" Hg (948 mbar)
C02	3.90 (1.8)	7.90 (3.6) ²	11.00 (5.0) ³
C03	5.50 (2.5) ²	10.90 (4.9) ³	15.30 (6.9) ³
C04	8.50 (3.9) ²	17.10 (7.8) ³	23.90 (10.8) ⁴
C05	4.80 (2.2) ²	9.50 (4.3) ³	13.30 (6.0) ³

NOTES:

14X factor of safety applied

2 Exceeds load capacity of UR 3

3 Exceeds load capacity of UR 5

4 Exceeds load capacity of UR 10

5 Actual time will vary based on cup selection, leakage and part shape

6 Average performance data shown. All data is for reference only. Please contact factory for assistance with your application

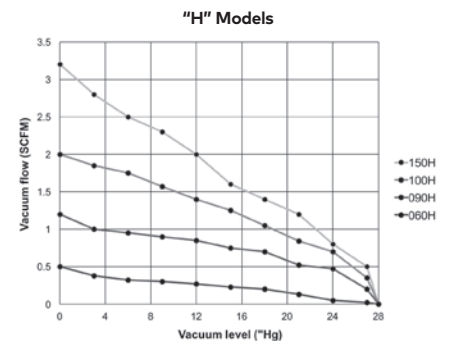
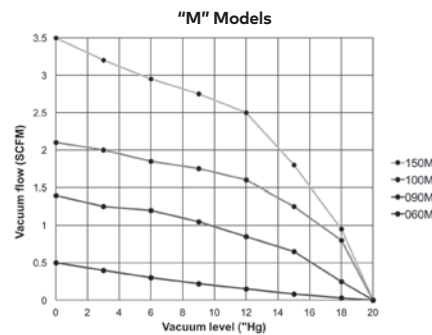
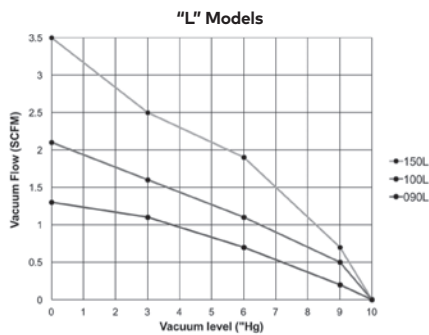

SPRING LEVELERS



- » Spring Levelers allow compliance for end-of-arm tools to ensure that all cups make contact. This is especially important when handling large objects such as sheets of plywood that may be warped and the tool has multiple vacuum cups that must make contact.
- » Smooth operation – reduces shock to an object that is being lifted
- » Lightweight – reduces stress to robotic end effectors
- » High flow – maximize performance and holding force for porous objects
- » Flexible mounting options for robotic end effectors / EOAT
- » Reduces machine indexing when picking up material from a stack



Spring Levelers: Groups 1, 2, & 3 – NVSL1, NVSL2 & NVSL3

Part Number	A in. (mm)	B-Travel in. (mm)	C in. (mm)	D in. (mm)	E in. (mm)	F-Thread in. (mm)	H in. (mm)	J in. (mm)	Thickness in. (mm)	Weight oz (g)
NVSL1-20 NVSL1M-20	1.14 (29.0)	0.20 (5.1)	10-32 F (M5 F)				0.19 (4.8)			1.7 oz (48g)
NVSL1-40 NVSL1M-40	1.54 (39.1)	0.40 (10.2)	10-32 F (M5 F)	0.15 (19.0)	0.75 (19.0)	1/2-20 UNF	0.39 (9.9)	0.75 (19.1)	0.43 (10.9)	1.8 oz (51g)
NVSL1-80 NVSL1M-80	2.32 (58.9)	0.80 (20.3)	10-32 F (M5 F)				0.77 (19.6)			1.9 oz (54g)
NVSL1-120 NVSL1M-120	3.11 (79.0)	1.20 (30.5)	10-32 F (M5 F)				1.16 (29.5)			2.1 oz (60g)
NVSL2-40 NVSL2M-40	2.70 (68.6)	0.40 (10.1)	1/8 NPTM (G1/8 M)				0.80 (20.3)			2.6 oz (74g)
NVSL2-120 NVSL2M-120	4.27 (108.5)	1.20 (30.5)	1/8 NPTM (G1/8 M)	0.24 (28.0)	0.88 (22.2)	5/8-18 UNF	1.57 (39.9)	1.10 (27.9)	0.72 (18.3)	3.2 oz (91g)
NVSL2-200 NVSL2M-200	5.83 (148.1)	2.00 (50.8)	1/8 NPTM (G1/8 M)				2.33 (59.2)			4 oz (113g)
NVSL2-280 NVSL2M-280	7.41 (188.2)	2.80 (71.1)	1/8 NPTM (G1/8 M)				3.11 (79.0)			4.6 oz (130g)
NVSL3-120	4.27 (108.5)	1.20 (30.5)					1.17 (29.7)			5.9 oz (117g)
NVSL3-200	5.83 (148.1)	2.00 (50.8)					1.93 (49.0)			7.3 oz (207g)
NVSL3-280	7.41 (188.2)	2.80 (71.1)	1/4 NPTM	0.31 (7.9)	1.13 (28.6)	7/8-14 UNF	2.71 (68.8)	1.50 (38.1)	1.02 (25.9)	8.7 oz (247g)
NVSL3-360	9.00 (228.6)	3.60 (91.4)					3.50 (88.9)			10.1 oz (286g)

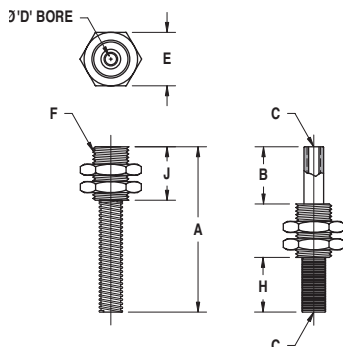

Spring Leveler Group 1

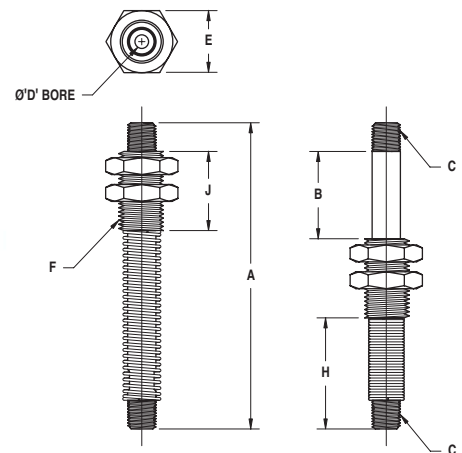

Spring Leveler Groups 2 & 3



Custom Vacuum Spring Levelers - NVSL Series

Ideal for OEM engineers and designers

- » Creative Engineering
- » Precision Manufacturing
- » Extensive Application Experience

When off the shelf doesn't work, Norgren's engineering expertise and manufacturing capabilities can provide custom solutions to your specifications.

Whether it's as simple as modifying a standard product, or more complex requiring new products with precise tolerances, or special materials, Norgren has the solution.

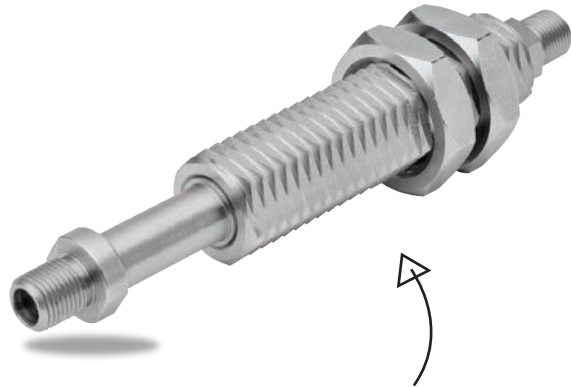

Our custom made 303 stainless steel spring leveler, vacuum cup and generator assembly attaches to swivel arm (not shown) for carton erecting application in food industry.



NVP1X-100H vacuum generator with pneumatic blow-off with stainless steel spring leveler.

Light Duty Spring Leveler Mounting Brackets

NSLBS Series – Mounting brackets for 1" [25mm] extrusions

NSLBF Series – Mounting brackets for 1.5" [40mm] extrusions

Ideal applications

- » End-of-arm-Tooling
- » Robotic assembly
- » Electronics
- » Pick & place
- » Injection Molding – parts removal

Features and benefits

- » Simple to assemble, modular
- » End-of-Arm Tooling component
- » Lightweight – Reduces stress to robotic end effector
- » Flexible mounting – Top, sides or bottom of extrusions
- » Easily adjusted and repositioned in seconds

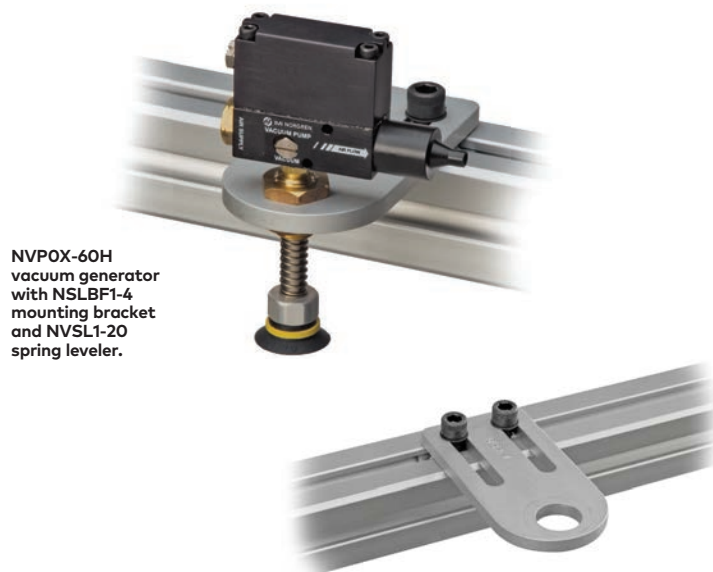

NVPOX-60H vacuum generator with NSLBF1-4 mounting bracket and NVSL1-20 spring leveler.

Quick change brackets for flexible mounting positions

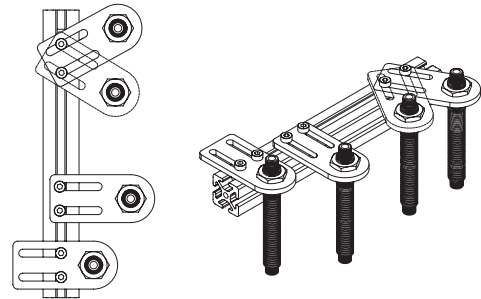

Flexible mounting positions

Designed for flexible manufacturing operations, NSLBF and NSLBS Series mounting brackets attach to the top, sides or bottom of 1" [25mm] and 1.5" [40mm] extrusions.

Easily mounted and adjusted, the Light Duty Spring Leveler Brackets readily rotate, slide or pivot for accurate part alignment. If the part size or process should change, you can re-position the brackets in a matter of seconds.

Using your extrusions or ours, NSLBF and NSLBS Series mounting brackets connect to our NVSL Series Spring Levelers (see page 207) and a variety of our venturi vacuum generators to create a simple, off-the-shelf End-of-Arm device.

Standard Spring Leveler Brackets:

- » 3 Series: Fits NVSL1, 2, 3 spring levelers
- » 4 Sizes: 2", 3", 4" and 5" lengths
- » Anodized aluminum

Spring Leveler Bracket Options:

- » Spring levelers, vacuum cups and vacuum fittings
- » Swivel attachment – Available for Series 3 only
- » Mounting hardware: 1/4" (6.5mm) T-slot compatible or 5/16" (10mm) T-slot compatible

7 SPRING LEVELERS



Light Duty Spring Leveler Mounting Bracket Assemblies:

(Norgren-supplied or customer-supplied extrusions)

NSLBS Series

1" [25mm] extrusion,
1/4" [6.5mm] T-slot compatible

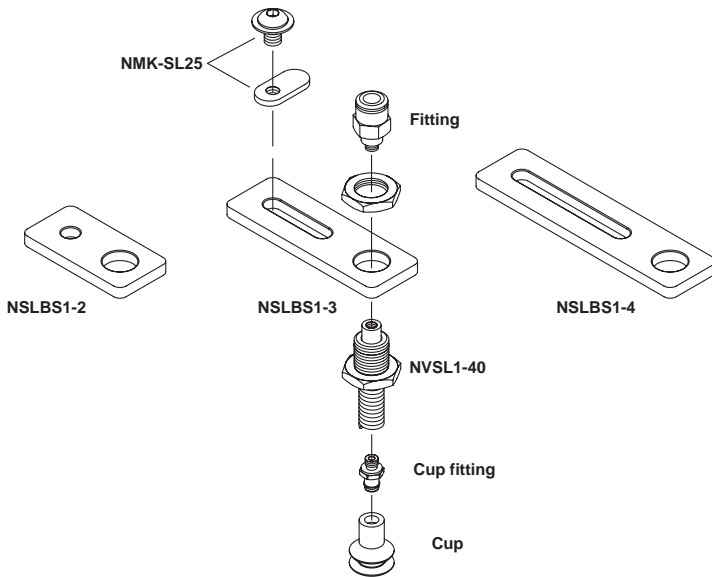

NSLBF Series

1.5" [40mm] extrusion,
5/16" [10mm] T-slot compatible

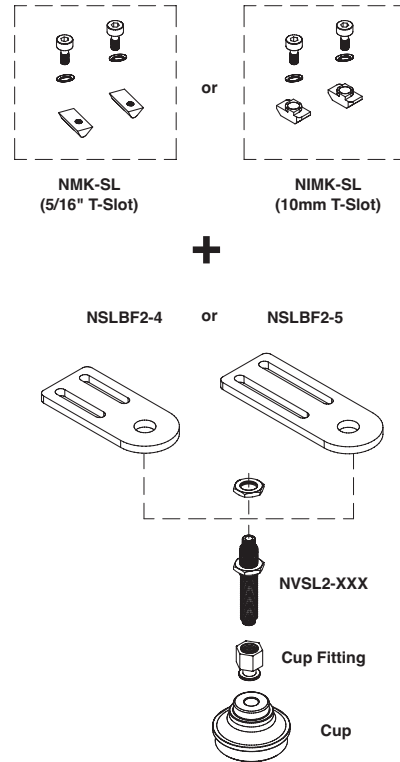

How to specify

Bracket Model Number	Size in (mm)	For use with Norgren Spring Levelers
NSLBS1-2	2.00 (50.0)	NVSL1/I-NVSL1-(20, 40, 80, 120)
NSLBS1-3	3.00 (76.2)	NVSL1/I-NVSL1-(20, 40, 80, 120)
NSLBS1-4	4.00 (101.6)	NVSL1/I-NVSL1-(20, 40, 80, 120)
NSLBF1-4	4.00 (101.6)	NVSL1/I-NVSL1-(20, 40, 80, 120)
NSLBF1-5	5.00 (127.0)	NVSL1/I-NVSL1-(20, 40, 80, 120)
NSLBS2-2	2.00 (50.8)	NVSL2/I-NVSL2-(40, 120, 200, 280)
NSLBS2-3	3.00 (76.2)	NVSL2 I-NVSL2-(40, 120, 200, 280)
NSLBS2-4	4.00 (101.6)	NVSL2 I-NVSL2-(40, 120, 200, 280)
NSLBF2-4	4.00 (101.6)	NVSL2 I-NVSL2-(40, 120, 200, 280)
NSLBF2-5	5.00 (127.0)	NVSL2 I-NVSL2-(40, 120, 200, 280)
NSLBF3-4	4.00 (101.6)	NVSL3 I-NVSL3-(120, 200, 280, 360)
NSLBF3-5	5.00 (127.0)	NVSL3 I-NVSL3-(120, 200, 280, 360)
NMK-SL25	N/A	Mounting hardware - 1/4" T-slot
NMK-SL	N/A	Mounting hardware - 5/16" T-slot
NIMK-SL	N/A	Mounting hardware - 10mm T-slot

Helpful hints:

1. Choose cup size/style based on part size and weight.
2. Choose spring leveler based on stroke length and bore size.
3. Choose bracket based on reach requirement 2", 3", 4" or 5".
4. Choose cup fitting based on thread size that matches spring leveler thread size (10-32F, 1/8 NPTM, 1/4 NPTM).

Please order Spring Level Brackets as separate line item(s) based on part number i.e. NSLBF1-4

Please order Spring Levelers as separate line item(s) based on part number i.e. NVSL1-20.

Please order Mounting Hardware as separate line item(s) based on part number i.e. NMK-SL

If you would like parts factory assembled, please specify on order "factory assembled."

Light Duty Spring Leveler Brackets – Series NSLBS Series

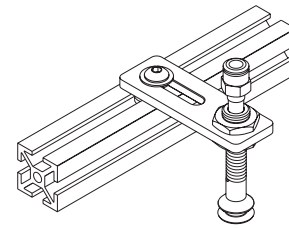
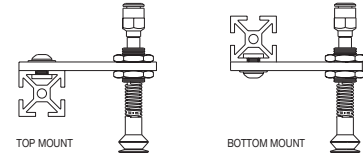

Flexible mounting positions

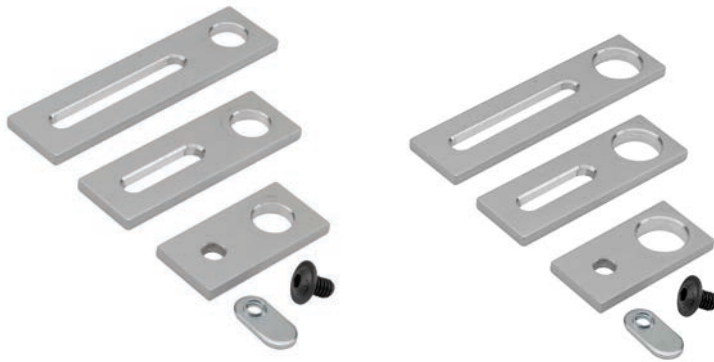

NSLBS1- (2, 3, 4)
with hardware

NSLBS2- (2, 3, 4)
with hardware

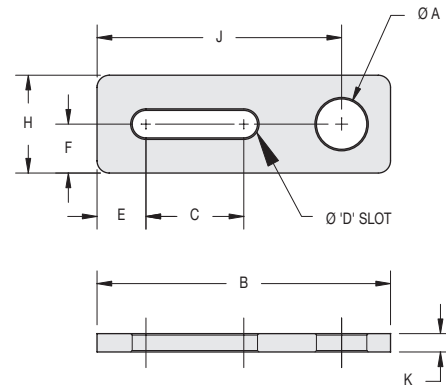

Dimensions

Part Number	A-Diameter in. (mm)	B in. (mm)	C in. (mm)	D in. (mm)	E in. (mm)	F in. (mm)	H in. (mm)	J in. (mm)	K in. (mm)	Weight oz (g)
NSLBS1-2		2.00 (50.8)	0.28 (7.1)					1.50 (38.1)		0.5 oz (14g)
NSLBS1-3	0.51 (13.0)	3.00 (76.2)	1.00 (25.4)					2.50 (63.5)		0.8 oz (23g)
NSLBS1-4		4.00 (101.6)	2.00 (50.8)					3.50 (88.9)		0.9 oz (26g)
NSLBS2-2		2.00 (50.8)	0.28 (7.1)	0.28 (7.1)	0.50 (12.7)	0.50 (12.7)	1.00 (25.4)	1.50 (38.1)	0.19 (4.80)	0.5 oz (14g)
NSLBS2-3	0.64 (16.3)	3.00 (76.2)	1.00 (25.4)					2.50 (63.5)		0.8 oz (23g)
NSLBS2-4		4.00 (101.6)	2.00 (50.8)					3.50 (88.9)		0.9 oz (26g)

7 SPRING LEVELERS



END-OF-ARM TOOLING

Light Duty Spring Leveler Brackets – Series NSLBF Series



NSLBF2- (4, 5)

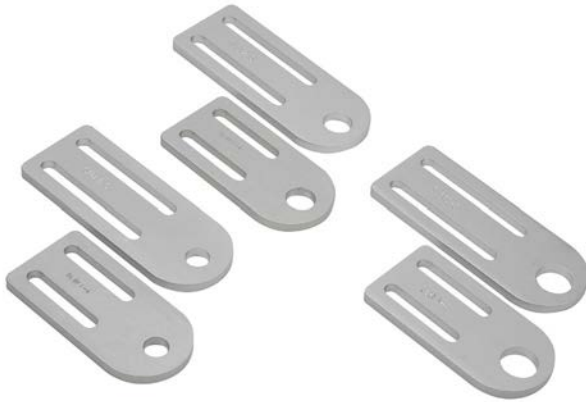

NSLBF1- (4, 5)

NSLBF3- (4, 5)

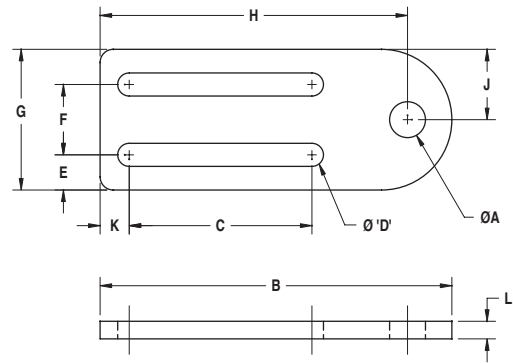

Dimensions

Part Number	A-Diameter in. (mm)	B in. (mm)	C in. (mm)	D in. (mm)	E in. (mm)	F in. (mm)	G in. (mm)	H in. (mm)	J in. (mm)	K in. (mm)	L in. (mm)	Weight oz (g)
NSLBF1-4	0.51 (13.0)	4.00 (101.6)	1.60 (40.6)					3.37 (85.6)				2.8 oz (79g)
NSLBF1-5	0.51 (13.0)	5.00 (127.0)	2.60 (66.0)					4.37 (111.0)				2.9 oz (82g)
NSLBF2-4	0.64 (16.3)	4.00 (101.6)	1.60 (40.6)					3.37 (85.6)				2.8 oz (79g)
NSLBF2-5	0.64 (16.3)	5.00 (127.0)	2.60 (66.0)	0.33 (8.3)	0.50 (12.7)	1.00 (25.4)	2.00 (50.8)	4.37 (111.0)	1.00 (25.4)	0.41 (10.4)	0.25 (6.4)	2.8 oz (79g)
NSLBF3-4	0.89 (22.6)	4.00 (101.6)	1.60 (40.6)					3.37 (85.6)				2.3 oz (65g)
NSLBF3-5	0.89 (22.6)	5.00 (127.0)	2.60 (66.0)					4.37 (111.0)				2.8 oz (79g)

Heavy Duty Spring Levelers/Level Compensators

Ideal applications

- » End-of-Arm Tooling
- » Press load and unload
- » automotive automation
- » Robotic assembly
- » Pick & place
- » Sheet feeding
- » Stamping press transfer

Features and benefits

- » Easy to assemble, modular End-of-Arm Tooling components – Minimal design time required
- » Durable – Rigid mounting design for heavy, high impact loads
- » Smooth operation – Reduces shock to an object that is being lifted
- » Lightweight – To maximize robot payload and increase robot speed
- » High flow – Maximize performance and holding force for handling porous objects
- » Flexible mounting options facilitates
- » End-of-Arm Tooling tool design

NSLB40 (2, 3)

Mounting brackets compatible with 1.50" (40 mm) extrusions, 5/16" (10 mm) T-slot



Heavy Duty Spring Levelers lift parts from different horizontal levels or uneven surfaces.

When handling sensitive objects such as fruit, Norgren Spring Levelers feature a soft touch allowing compliance for end-of-arm tools to ensure that all cups make contact. This is especially important when handling large objects such as sheets of plywood that may be warped and the tool has multiple vacuum cups that must make contact.

Norgren's Spring Leveler design surpasses the competition. We offer large thru-bores that allow higher vacuum flow to overcome leakage and for rapid evacuation to ensure safe handling operations

For design flexibility, Norgren offers a large range of sizes and travel lengths 0.20" (5 mm) to 3.6" (91 mm) to accommodate the necessary over-driving by the lifting mechanism to bring all cups in contact.

Recommended for applications which require lifting heavy loads without deflection, Norgren Heavy Duty Spring Levelers include a rigid mounting bracket for a strong, solid connection to 1.50" (40 mm) extrusions.

Standard Spring Levelers:

- » 2 Series: 1/8" and 1/4" NPT male thread
- » 8 Models: Travel lengths from 0.40" to 3.60" (10 mm to 91 mm)
- » Nickel plated steel shafts, stainless steel springs, high performance bearings and aluminum body

Spring Leveler Options:

- » Vacuum cups and vacuum fittings
- » Swivel attachment – Available for Series 3 only



Heavy Duty Spring Leveler Mounting Assembly

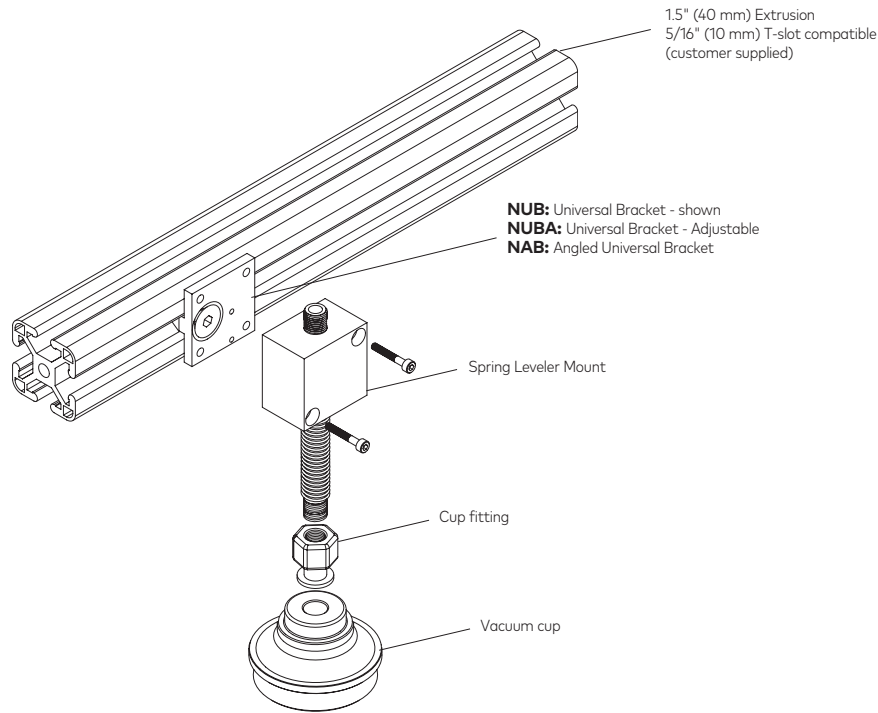

How to specify

Part Number	Heavy Duty Spring Leveler Mounting Assembly
Series 2	
NSLB40/NSLB40M-2-40	0.40" (10.2 mm) travel, 1/8 NPT male thread
NSLB40/NSLB40M-2-120	1.20" (30.5 mm) travel, 1/8 NPT male thread
NSLB40/NSLB40M-2-200	2.00" (50.8 mm) travel, 1/8 NPT male thread
NSLB40/NSLB40M-2-280	2.80" (71.1 mm) travel, 1/8 NPT male thread
Series 3	
NSLB40/NSLB40M-3-120	1.20" (10.2 mm) travel, 1/4 NPT male thread
NSLB40/NSLB40M-3-200	2.00" (30.5 mm) travel, 1/4 NPT male thread
NSLB40/NSLB40M-3-280	2.80" (50.8 mm) travel, 1/4 NPT male thread
NSLB40/NSLB40M-3-360	3.60" (71.1 mm) travel, 1/4 NPT male thread

When ordering spring levelers check the "B" dimension for travel range.

Please order spring levelers as separate line items based on part number i.e. NSLB40-2-40

If you would like parts factory assembled, please specify on order "factory assembled."

To attach Heavy Duty Spring Levelers to extrusions, please see Universal Bracket mounting options.

Heavy Duty Spring Levelers – Series NSLB40-2, NSLB40-3

Part Number	Dimension									Weight oz (g)
Series 2	A in. (mm)	B-Travel in. (mm)	C in. (mm)	D in. (mm)	E in. (mm)	F in. (mm)	H in. (mm)	J, L in. (mm)	K, M in. (mm)	
NSLB40-2-40 NSLB40M-2-40	2.70 (68.6)	0.40 (10.2)	1/8 NPTM (G1/8 M)				0.40 (10.2)			4.7 oz (133g)
NSLB40-2-120 NSLB40M-2-120	4.27 (108.5)	1.20 (30.5)	1/8 NPTM (G1/8 M)	0.24 (6.1)	0.21 (5.2)	1.00 (25.4)	1.17 (29.7)	1.10 (27.9)	1.50 (38.1)	4.7 oz (133g)
NSLB40-2-200 NSLB40M-2-200	5.83 (148.1)	2.00 (50.8)	1/8 NPTM (G1/8 M)				1.93 (49.0)			5.3 oz (150g)
NSLB40-2-280 NSLB40M-2-280	7.41 (188.2)	2.80 (71.1)	1/8 NPTM (G1/8 M)				2.71 (68.8)			5.9 oz (167g)

Part Number	Dimension									Weight oz (g)
Series 3	A	B-Travel in. (mm)	C in. (mm)	D in. (mm)	E in. (mm)	F in. (mm)	H in. (mm)	J, L in. (mm)	K, M in. (mm)	
NSLB40-3-120 NSLB40M-3-120	4.27 (108.5)	1.20 (30.5)	1/4 NPTM (G1/4 M)				1.17 (29.7)			6.9 oz (196g)
NSLB40-3-200 NSLB40M-3-200	5.83 (148.1)	2.00 (50.8)	1/4 NPTM (G1/4 M)	0.31 (7.9)	0.21 (5.2)	1.00 (25.4)	1.93 (49.0)	1.10 (27.9)	1.50 (38.1)	7.9 oz (224g)
NSLB40-3-280 NSLB40M-3-280	7.41 (188.2)	2.80 (71.1)	1/4 NPTM (G1/4 M)				2.71 (68.8)			9.9 oz (281g)
NSLB40-3-360 NSLB40M-3-360	9.00 (228.6)	3.60 (91.4)	1/4 NPTM (G1/4 M)				3.49 (88.6)			11 oz (312g)



Series 2
NSLB40-2 (40, 120, 200, 280)



Series 3
NSLB40-3 (120, 200, 280, 360)

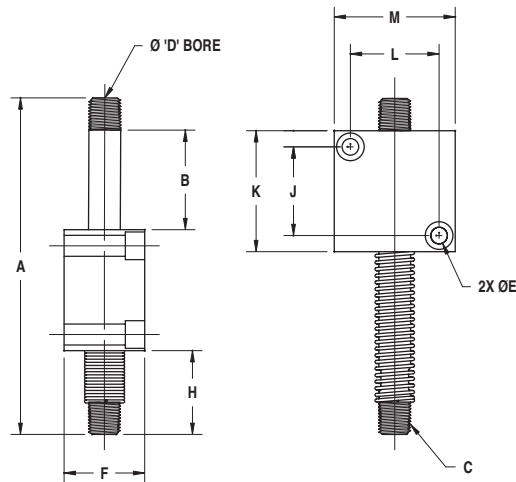



Adjustable, Fixed Extension Shaft & Mounting Brackets

Ideal applications

- » Injection molding
- » Pick & place of irregular shaped parts with large surface height differences

Features and benefits

- » Easy to assemble, modular End-of-Arm tool components – minimal design time required
- » Fixed positioning for consistent indexing and part retention
- » Rigid mounting design for heavy, high impact loads
- » Smooth operation – reduces shock to an object that is being lifted
- » Lightweight – to maximize robot payload and increase robot speed
- » High flow – maximize performance and holding force for handling porous objects
- » Flexible mounting options facilitates
- » End-of-Arm tool design

NFEB40 (2, 3) -
Mounting brackets compatible with 1.5" (40 mm) extrusions, 5/16" (10 mm) T-slot



NFEB40-3 with bellows Vacuum cup.

Adjustable, Fixed Extension Shaft & Bracket is a rigid, non-moving rod that mounts to the top, sides or bottom of 1.5" (40 mm) extrusions. Once the shaft is adjusted to meet a specific height requirement, the bracket is clamped into a fixed position.

Designed for flexible manufacturing operations, the NFEB40 Series is easily repositioned by simply loosening 2 collar screws and sliding the shaft up or down to meet the new height requirements. For added adjustability, add an adjustable universal bracket to slide the NFEB40 left or right.

Standard Adjustable, Fixed Extension Shaft & Bracket:

- » **2 Series:** 1/8 or 1/4 NPT male
- » **8 Shaft Lengths:** 0.40" to 6.7" (10 mm to 170 mm)
- » **Mounting:** Split collar design
- » **Material:** Nickel plated steel shafts and aluminum body

Adjustable, Fixed Extension Shaft & Bracket Options:

- » Wide variety of vacuum cups and vacuum fittings
- » Universal brackets for easy attachments and adjustable positioning
- » Vacuum cup Swivel attachment – available for Series 3 only

Adjustable Fixed Length Extension Brackets: NFEB40- (2, 3) – Configurations and Options:

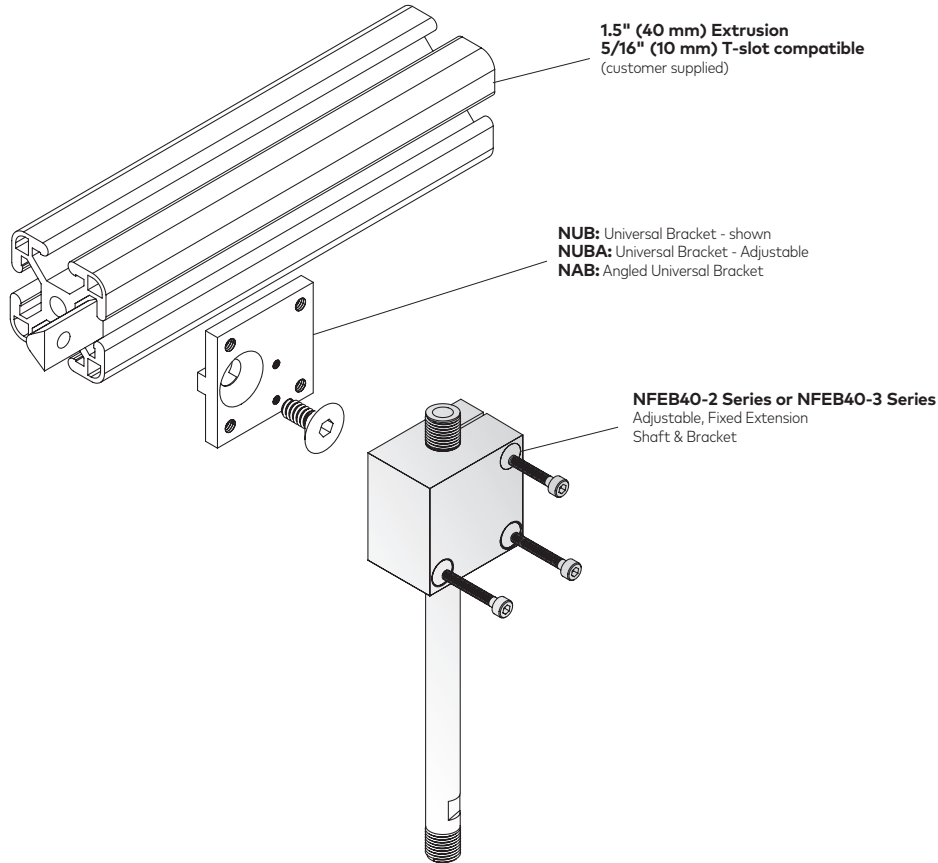

How to specify

Part Number	Adjustable, Fixed Extension Shaft & Brackets
Series 2	
NFEB40/NFEB40M-2-40	0.40" (10.2 mm) extension length, 1/8 NPT (G1/8) male
NFEB40/NFEB40M-2-120	1.97" (50.0 mm) extension length, 1/8 NPT (G1/8) male
NFEB40/NFEB40M-2-200	3.51" (89.2 mm) extension length, 1/8 NPT (G1/8) male
NFEB40/NFEB40M-2-280	5.11" (129.8 mm) extension length, 1/8 NPT (G1/8) male
Series 3	
NFEB40/NFEB40M-3-120	1.97" (50.1 mm) extension length, 1/4 NPT (G1/4) male
NFEB40/NFEB40M-3-200	3.51" (89.2 mm) extension length, 1/4 NPT (G1/4) male
NFEB40/NFEB40M-3-280	5.11" (129.8 mm) extension length, 1/4 NPT (G1/4) male
NFEB40/NFEB40M-3-360	6.70" (170.2 mm) extension length, 1/4 NPT (G1/4) male

To specify **NFEB40**, choose part number based on extension length desired, thru bore diameter and thread size on each end of shaft.

Please order NFEB40's as separate line items based on part number. i.e. **NFEB40-2-280**. To order metric threads place an "I-" in front of the part number. Example: **NFEB40M-2-280**.

Please order Universal brackets (NUB, NUBA or NAB) as separate line items based on part numbers.

To attach Adjustable, Fixed Extension Shafts & Brackets to extrusions, please see Universal Bracket mounting options.

7 SPRING LEVELERS



END-OF-ARM TOOLING

Adjustable – Fixed Length Extension Shafts & Brackets

Part Number	Dimension A in. (mm)	B in. (mm)	C in. (mm)	D in. (mm)	E in. (mm)	F in. (mm)	H in. (mm)	J, L in. (mm)	K, M in. (mm)	Weight oz (g)
Series 2										
NFEB40-2-40 NFEB40M-2-40	2.70 (68.6)	0.40 (10.2)	1/8 NPTM (G1/8 M)				0.80 (20.3)			4.7 oz (133g)
NFEB40-2-120 NFEB40M-2-120	4.27 (108.5)	1.97 (50.0)	1/8 NPTM (G1/8 M)				2.37 (60.2)			4.7 oz (133g)
NFEB40-2-200 NFEB40M-2-200	5.83 (148.1)	3.51 (89.2)	1/8 NPTM (G1/8 M)	0.24 (6.1)	0.21 (5.2)	1.00 (25.4)	3.91 (99.3)	1.10 (27.9)	1.50 (38.1)	5.3 oz (150g)
NFEB40-2-280 NFEB40M-2-280	7.41 (188.2)	5.11 (129.8)	1/8 NPTM (G1/8 M)				5.51 (140.0)			5.9 oz (167g)

Part Number	Dimension A in. (mm)	B in. (mm)	C in. (mm)	D in. (mm)	E in. (mm)	F in. (mm)	H in. (mm)	J, L in. (mm)	K, M in. (mm)	Weight oz (g)
Series 3										
NFEB40-3-120 NFEB40M-3-120	4.27 (108.5)	1.97 (50.0)	1/4 NPTM (G1/4 M)				2.37 (60.2)			6.9 oz (196g)
NFEB40-3-200 NFEB40M-3-200	5.83 (148.1)	3.51 (89.2)	1/4 NPTM (G1/4 M)	0.31 (7.9)	0.21 (5.2)	1.00 (25.4)	3.91 (99.3)	1.10 (27.9)	1.50 (38.1)	7.9 oz (224g)
NFEB40-3-280 NFEB40M-3-280	7.41 (188.2)	5.11 (129.8)	1/4 NPTM (G1/4 M)				5.51 (140.0)			9.9 oz (281g)
NFEB40-3-360 NFEB40M-3-360	9.00 (228.6)	6.70 (170.2)	1/4 NPTM (G1/4 M)				7.10 (180.3)			11 oz (312g)



Series 2
NFEB40-2- (40, 120, 200, 280)

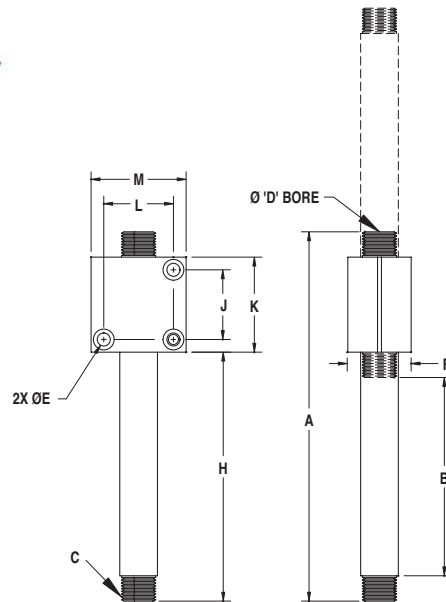

Series 3
NFEB40-3-(120, 200, 280, 360)

Vacuum Cup Locking Angle Joint

Ideal applications

- » Stamping operations (press load and unload)
- » Palletizing
- » Handling curved and angular objects

Features and benefits

- » Durable – rugged all steel design
- » Full 40° angular / conical movement (20° in each direction)
- » Smooth and secure operation – follows contour of object being lifted
- » High flow – maximize performance and holding force for handling porous objects
- » Flexible mounting options facilitates
- » End-of-Arm Tooling tool design

NCSJ3 Series 3 -
Mounting brackets compatible with 1.5" (40 mm) extrusions, 5/16" (10 mm) T-slot



NCSJ3-14 Vacuum Cup Locking Angle Joint with NSLB40-3 Heavy Duty Spring Leveler & Bracket and Vacuum Cup.



NCSJ3-38

Handling curved surfaces is easy with Norgren's Vacuum Cup Locking Angle Joint. The NCSJ3 angle joints attach to a spring leveler and vacuum cup providing a 40° angular / conical movement. To control the degree of swivel, simply tighten the collar nut located on top of the angle joint to restrict movement.

Developed in conjunction with Norgren spring levelers, the NCSJ3 angle joint assemblies feature exceptionally large flow paths to safely handle porous objects. Depending on height and tooling requirements, Vacuum Cup Locking Angle Joints are interchangeable with the following Series 3 spring levelers:

NVSL3 – Standard spring levelers

NSLB40-3 – Heavy duty spring levelers

NFEB40-3 – Fixed extension shafts & brackets

Note: The retaining nut must be locked into position to seal.

Standard Vacuum Cup Locking Angle Joint:

- » 3 Sizes: 1/4, 3/8, 1/2 NPT male threads – mates to a wide variety of vacuum cup fittings
- » 1/4 NPTF top port mates to all the 1/4 NPT Series 3 levelers
- » Material: Nickel plated steel, Buna-N O-ring

Vacuum Cup Locking Angle Joint Options:

- » Variety of vacuum cups and vacuum fittings
- » Custom designs and stainless steel construction available for food and wash-down applications. Consult factory.

7 SPRING LEVELERS



END-OF-ARM TOOLING

Vacuum Cup Locking Angle Joint: NCSJ-3 Series:

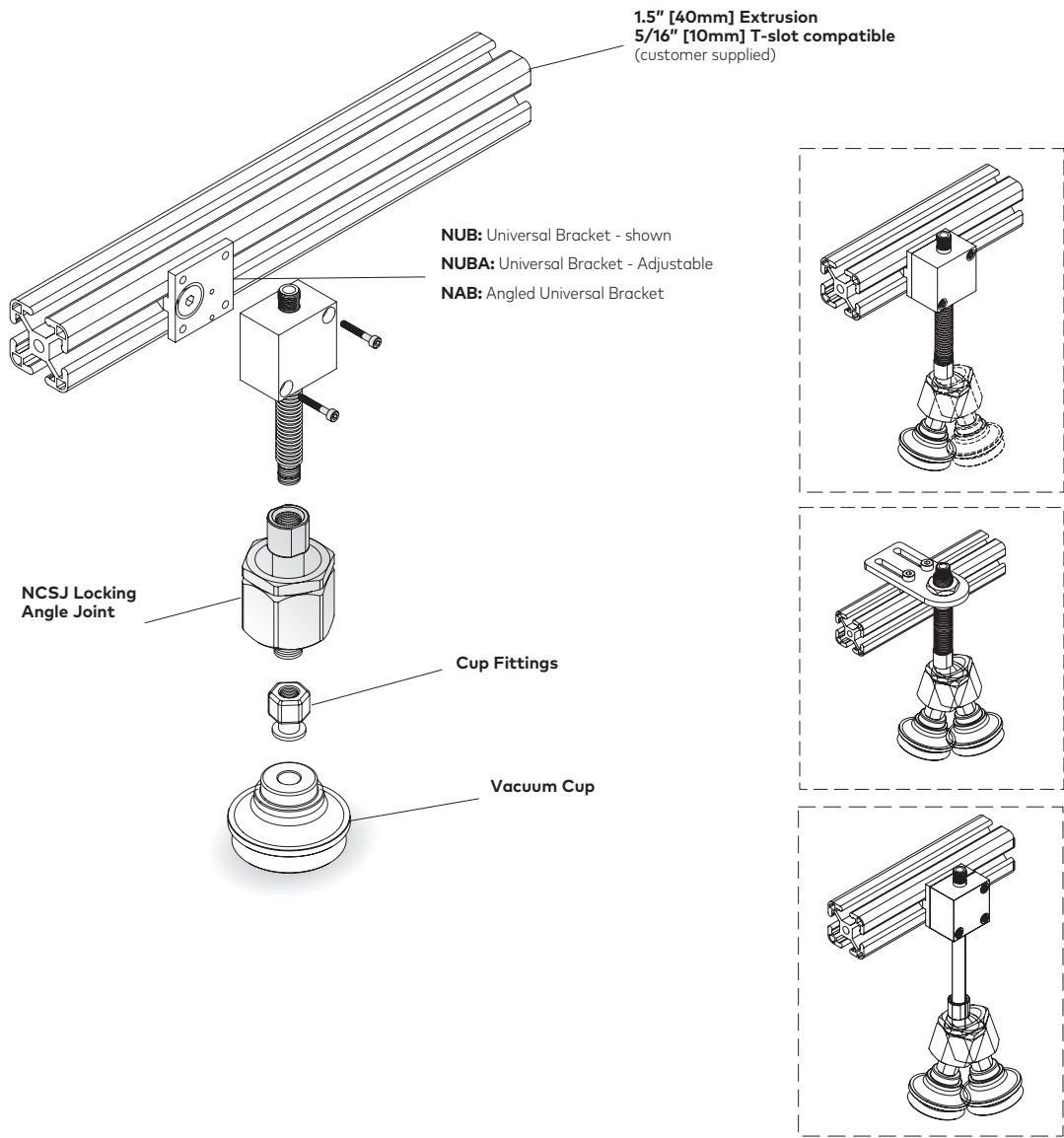

How to specify

Part Number	Vacuum Cup Locking Angle Joint
NCSJ3-14	1/4 NPT - male thread
NCSJ3-38	3/8 NPT - male thread
NCSJ3-12	1/2 NPT - male thread

Choose the angle joint with the same NPT thread as the vacuum cup fitting.
Order by part number i.e. NCSJ3-38

Vacuum Cup Locking Angle Joint: Series 3 – NCSJ-3

Part Number	Dimensions A Thread in. (mm)	B Thread in. (mm)	C Thru Bore in. (mm)	D in. (mm)	E in. (mm)	F Hex in. (mm)	H Locking Angle in. (mm)	Weight oz (g)
NCSJ3-14	1/4 NPT			1.96 (49.8)	2.90 (73.7)			11.7 oz (332g)
NCSJ3-38	3/8 NPT	1/4 NPT	0.31 (7.9)	2.06 (52.3)	3.00 (76.2)	1.50 (38.1)	40°	12.7 oz (360g)
NCSJ3-12	1/2 NPT			2.06 (52.3)	3.00 (76.2)			12.7 oz (360g)

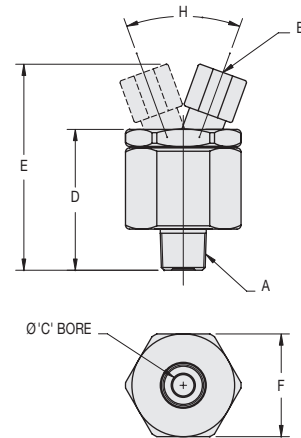



Universal Mounting Brackets – Standard, Adjustable, Angled

- » 3 Styles – standard, adjustable or angled with simple erector-set connectivity
- » Anodized aluminum – lightweight – reduces stress, extends performance and life of robot
- » Modular components add design flexibility – adaptable for all EOAT configurations
- » Keyed profile for tight fit – non-rotating – strong holding force
- » Mounting kit includes hardware to attach products to extrusions
- » Angled brackets have optional adjustment knob, consult factory

Compatible with 1" (25 mm) and 1.5" (40 mm) extrusions



Standard Universal Bracket attaches NVP10-100H to extrusion for halogen bulb pick and place operation.



Universal Bracket(Adjustable) with Vacuum cup/Manifold block assembly.



Angled Bracket holds NVP10-60M vacuum generator and cup, with exposed fastening screw for quick and easy adjustments.



NUB, NUBA, and NAB brackets.

Universal Mounting Brackets are simple, lightweight connectors that attach Norgren vacuum generators, vacuum cups, spring levelers and manifold blocks to 1" or 1.5" extrusions.

Available in 3 models, standard, adjustable or angled, our Universal Brackets are keyed to fit securely in 1/4" [6.5mm] or 5/16" [10mm] T-slots, remain square and increase holding force.

Brackets are available with or without mounting hardware.

Standard Universal Bracket: (NUB)

The standard NUB is a fixed position bracket that is tamper resistant. Once the screw is tightened to the extrusion and a product is mounted to the bracket the fastening screw is now covered and inaccessible to adjust.

Universal Bracket Adjustable: (NUBA)

An elongated version of the standard bracket, the NUBA features an exposed fastening screw that enables quick, easy bracket adjustments along the T-slot.

Angled Universal Bracket: (NAB)

For operations that require frequent adjustments, the NAB models are the easiest to re-position. One side of the bracket holds the vacuum generator, the other side of the bracket attaches to the extrusion enabling the bracket assembly to slide along the T-slot for unlimited adjustments. With the generator located on a 90° angle, the fastening screw is easily accessible at all times. Optional adjustment knobs are available for the NAB models.

Universal Brackets and Mounting Kits for 1" Extrusions



Bracket only: NUB18-25



Bracket & Mounting Kit: NMK-NUB18-25

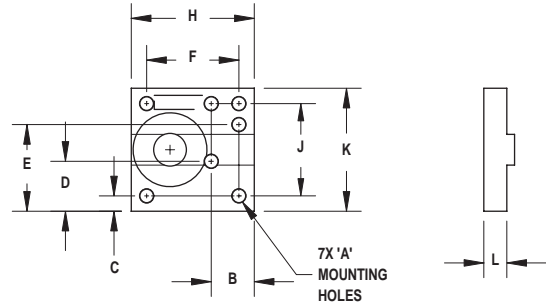

Bracket accepts: NVPO0, NVPOX, NVP10 & NVP1X Series generators and NMB18-25 manifold block.

Part Number		Dimensions								Weight oz (g)
		A- Mtg Holes	B in. (mm)	C in. (mm)	D in. (mm)	E in. (mm)	F, J in. (mm)	H, K in. (mm)	L in. (mm)	
NUB18-25	Fits 1/4 T-Slot (Fits 6.5 mm T-Slot)	M3 x 0.5	0.35 (8.9)	0.13 (3.2)	0.41 (10.3)	0.70 (17.8)	0.75 (19.1)	1.00 (25.4)	0.19 (4.7)	0.3 oz (9g)

Note 1: Mounting kit includes all hardware to mount generators and manifold block.
 Note 2: Depending on the generator being mounted, it may be necessary to rotate the bracket 180° from diagram shown.



Bracket only: NUB14-25



Bracket & Mounting Kit: NMK-NUB14-25

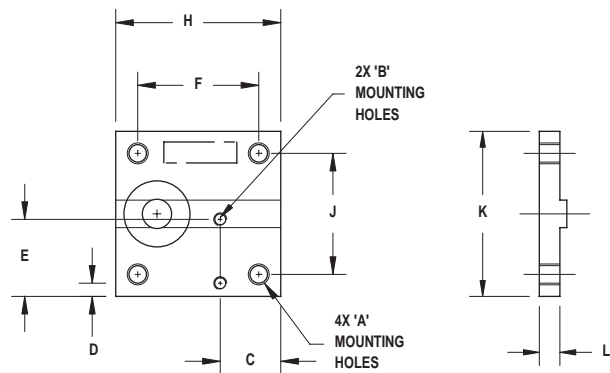

Bracket accepts all NVP Series generators except the NVPO0/VPOX Series. Fits All NMB14 Series manifold blocks. (Allows larger generators to be mounted to 1" extrusions).

Part Number		Dimensions								Weight oz (g)
		A- Mtg Holes	B- Mtg Holes	C in. (mm)	D in. (mm)	E in. (mm)	F, J in. (mm)	H, K in. (mm)	L in. (mm)	
NUB14-25	Fits 1/4 T-Slot (Fits 6.5 mm T-Slot)	10-32	M3 x 0.5	0.55 (14.0)	0.12 (3.0)	0.70 (17.8)	1.10 (27.9)	1.50 (38.1)	0.19 (4.7)	0.7 oz (20g)

Note 1: Mounting kit includes all hardware to mount generators and manifold block.

How to specify

Bracket only: See Model Numbers: i.e. **NUB18-25**

Bracket & Mounting Kit: Add "NMK" for mounting kit in front of Model Number i.e. **NMKUB18-25**

7 MOUNTING BRACKETS



END-OF-ARM TOOLING

Universal Brackets (Adjustable) and Mounting Kits for 1" Extrusions



Bracket only: NUBA18-25



Bracket & Mounting Kit: NMK-NUBA18-25

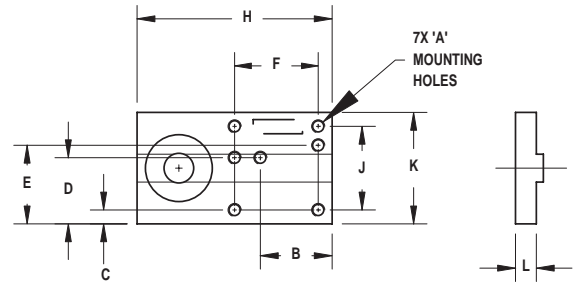

Bracket accepts: NVPO0, NVPOX, NVP10 & NVP1X Series generators and NMB18-25 manifold block.

Part Number		Dimensions									Weight oz (g)
		A- Mtg Holes	B in. (mm)	C in. (mm)	D in. (mm)	E in. (mm)	F, J in. (mm)	H in. (mm)	K in. (mm)	L in. (mm)	
NUBA18-25	Fits 1/4 T-Slot (Fits 6.5mm T-Slot)	M3 x 0.5	0.64 (16.4)	0.13 (3.2)	0.60 (15.2)	0.70 (17.8)	0.75 (19.1)	1.75 (44.5)	1.00 (25.4)	0.19 (4.7)	0.5 oz (14g)

Note 1: Mounting kit includes all hardware to mount generators and manifold block.



Bracket only: NAB18-25



Bracket & Mounting Kit: NMK-NAB18-25

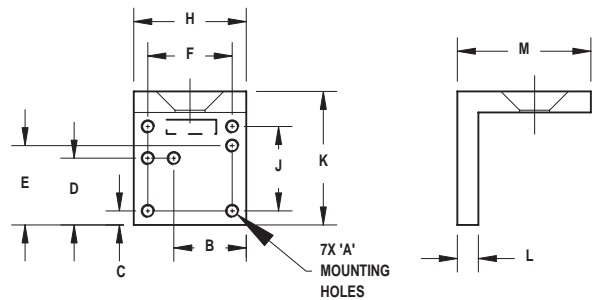

Bracket accepts: NVPO0, NVPOX, NVP10 & NVP1X Series generators and NMB18-25 manifold block.

Note 1: Mounting kit includes all hardware to mount generators and manifold block.

How to specify

Bracket only: See Model Numbers: i.e. **NAB18-25**

Bracket & Mounting Kit: Add "NMK" for mounting kit in front of Model Number i.e. **NMK-NAB18-25**

Universal Brackets and Mounting Kits for 1.5" Extrusions



Bracket only: NUB14-40 (5/16th T-slot)



Bracket only: NIUB14-40 (10mm T-slot)



Bracket and Mounting Kit:
NMK-NUB14-40 (5/16th T-slot)



Bracket and Mounting Kit:
NIMK-NUB14-40 (10mm T-slot)

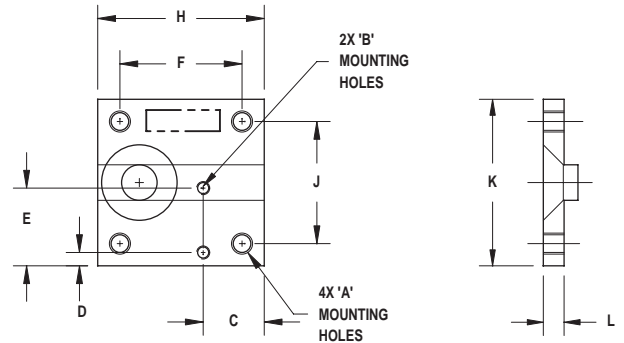

Accepts all NVP10 Series generators and above, and NMB14 manifold blocks.

Note 1: Mounting kit includes all hardware to mount generators and manifold block.

Part Number	A- Mtg Holes	B- Mtg Holes	C in. (mm)	D in. (mm)	E in. (mm)	F, J in. (mm)	H, K in. (mm)	L in. (mm)	Weight oz (g)
NUB14-40 Fits 5/16 T-Slot	10-32	M3 x 0.5	0.55	0.12	0.70	1.10	1.50	0.19	0.7 oz
NIUB14-40 (Fits 10mm T-Slot)			(14.0)	(3.0)	(17.8)	(27.9)	(38.1)	(4.7)	(20g)

Universal Brackets (Adjustable) and Mounting Kits for 1.5" Extrusions



Bracket only: NUBA14-40 (5/16th T-slot)



Bracket only: NIUBA14-40 (10mm T-slot)



Bracket and Mounting Kit:
NMK-NUBA14-40 (5/16th T-slot)



Bracket and Mounting Kit:
NIMK-NUBA14-40 (10mm T-slot)

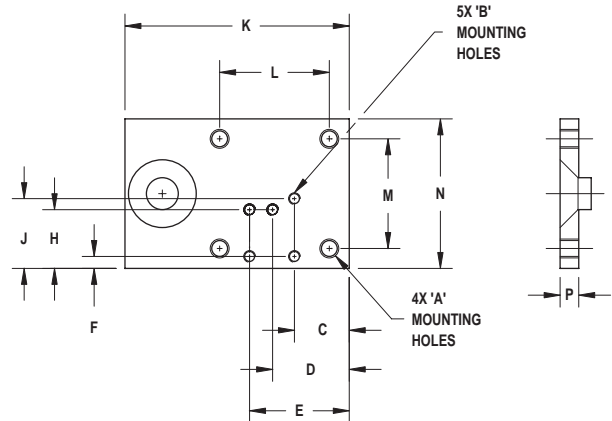

Accepts all NVP Series generators and NMB14 Cup Mounts.

Note 1: Mounting kit includes all hardware to mount generators and manifold block.

Part Number	A- Mtg Holes	B- Mtg Holes	C in. (mm)	D in. (mm)	E in. (mm)	F in. (mm)	H in. (mm)	J in. (mm)	K in. (mm)	L in. (mm)	M in. (mm)	N in. (mm)	P in. (mm)	Weight oz (g)
NUBA14-40 Fits 5/16 T-Slot	10-32	M3 x 0.5	0.55	0.77	1.00	0.12	0.59	0.70	2.25	1.10	1.10	1.50	0.19	1 oz
NIUBA14-40 (Fits 10mm T-Slot)			(14.0)	(19.5)	(25.4)	(3.0)	(15.0)	(17.8)	(57.2)	(27.9)	(27.9)	(38.1)	(4.7)	(28g)

How to specify

Bracket only: See Model Numbers: i.e. **NUB14-40**

Bracket & Mounting Kit: Add "NMK" for mounting kit in front of Model Number i.e. **NMK-NUB14-40**

7 MOUNTING BRACKETS



Angled Brackets and Mounting Kits for 1.5" Extrusions



Bracket only: NAB14-40



Bracket & Mounting Kit: NMK-NAB14-40
Available with optional adjustment knob.
See Bracket Construction Sequence below

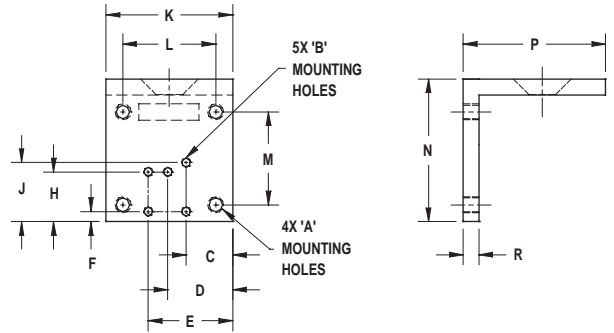

Accepts all NVP Series generators and NMB14 Cup Mounts.

Note 1: Mounting kit includes all hardware to mount generators and manifold block.

Part Number	Dimensions		C in. (mm)	D in. (mm)	E in. (mm)	F in. (mm)	H in. (mm)	J in. (mm)	K in. (mm)	L in. (mm)	M in. (mm)	N in. (mm)	P in. (mm)	R in. (mm)	Weight oz (g)
	A- Mtg Holes	B- Mtg Holes													
NAB14-40 Fits 5/16 T-Slot	10-32	M3 x 0.5	0.55	0.77	1.00	0.12	0.59	0.70	1.50	1.10	1.50	1.69	1.69	0.19	1oz
NIAB14-40 Fits 10mm T-Slot			(14.0)	(19.5)	(25.4)	(3.0)	(15.0)	(17.8)	(38.1)	(27.9)	(38.1)	(42.8)	(42.8)	(4.7)	(28g)

How to specify

Bracket only: See Model Numbers: i.e. **NUB14-40**

Bracket & Mounting Kit: Add "NMK" for mounting kit in front of Model Number i.e. **NMK-NUB14-40**

Bracket & Mounting Kit with Adjustment Knob: **NMK-NABK14-40** (angled brackets only)

Standard, Adjustable & Angled Bracket Construction Sequence:

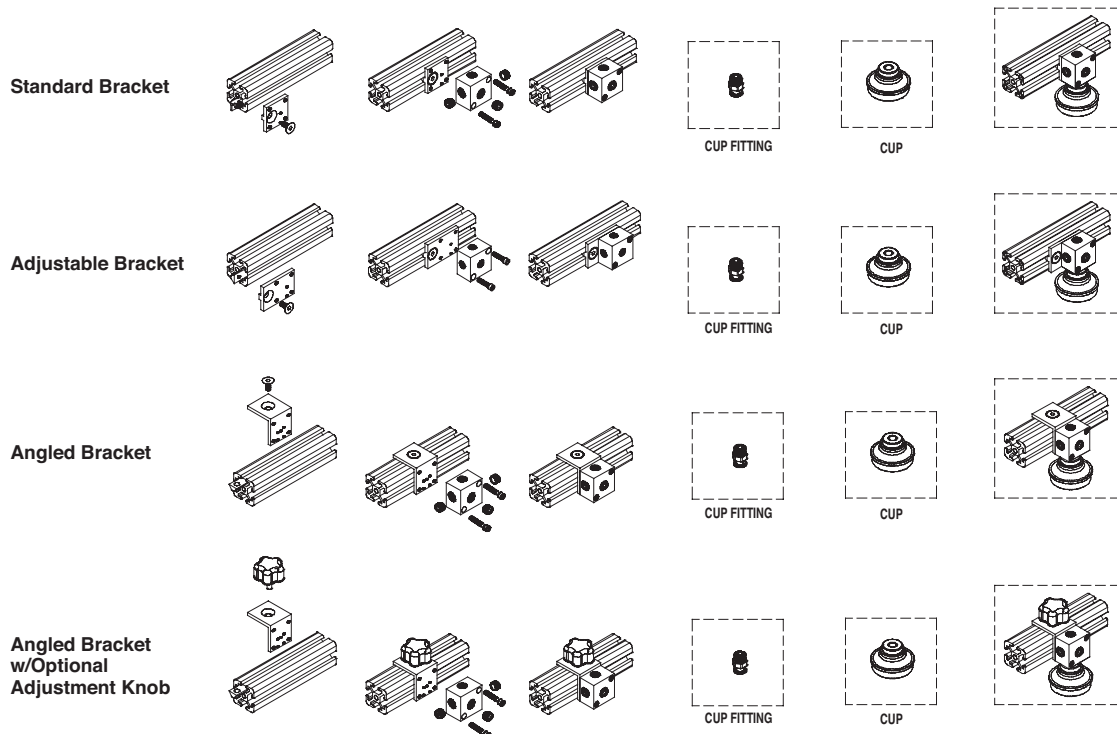

Vacuum Cup Mount/Manifold Block

Combination Cup Mount and Manifold Block Compatible with 1" (25 mm) and 1.5" (40 mm) extrusions

Ideal applications

- » • Robotic End Effectors/ End-of-Arm Tooling
- » • Removing products from molds
- » • Sheet metal transfer
- » • Palletizing of work pieces
- » • Nesting fixtures
- » • Assembly fixtures
- » • Pick & place

Features and benefits

- » • Direct mount for cups – maintains consistent height for all cups
- » • High performance – full vacuum flow out performs competition
- » • Easy to assemble, modular End-of-Arm Tooling components – minimal design time required
- » • Flexible design – 5 ports for easy plumbing, allows side entry vacuum, adaptable for all End-of-Arm Tooling configurations
- » • Square shape – easily mounts to any side of the extrusion, products stay square and flush
- » • Vacuum lines may be connected in series or home run plumbed to streamline the tooling fixture
- » • Anodized aluminum – lightweight, extends performance and life of robot, allows higher speeds
- » • Large thread sizes provides high flow rates for safe handling of porous objects



NMB14-40 Vacuum cup Mount/Manifold Block

Simplify your End-of-Arm tooling devices using our dual purpose NMB Series - Vacuum Cup Mount/Manifold Block. Whether you are mounting vacuum cups to extrusions and/or distributing vacuum to multiple locations, the NMB Series streamlines your design with one multi-functional component.

For design and plumbing flexibility, the NMB Series features five vacuum ports and three mounting options that easily connect vacuum generators and cups to 5/16" (10 mm) or 1/4" (6.50 mm) T-slot extrusions. Extra vacuum ports allow optional accessories to be directly mounted to the manifold block i.e. vacuum gauges or remotely plumbed such as vacuum switches, sensors or blow-off capabilities.

High vacuum flow is critical for handling porous objects. Norgren offers up to 3/4" NPT ports to ensure high flow paths.

Options:

3 Mounting port options: standard, bottom or face mount

9 Models: 1/8 to 3/4 NPT

3 Universal brackets: fixed, adjustable or angled



NVP80-200M distributes vacuum to four cup mount/manifold assemblies to pick up corrugated board.

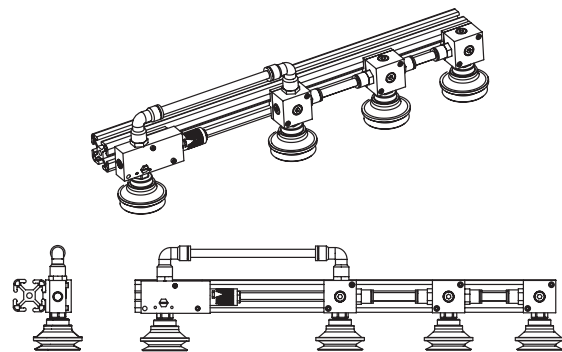

The Vacuum cup mount/manifold easily connects to the T-slot extrusion using a Universal Bracket.

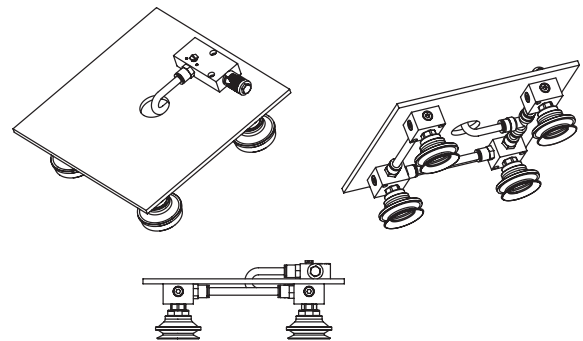

For non T-slot applications, attach the vacuum cup mount/manifold to the underside of a flat tooling plate head.



Vacuum Cup Mount/Manifold Configuration & Specifications:

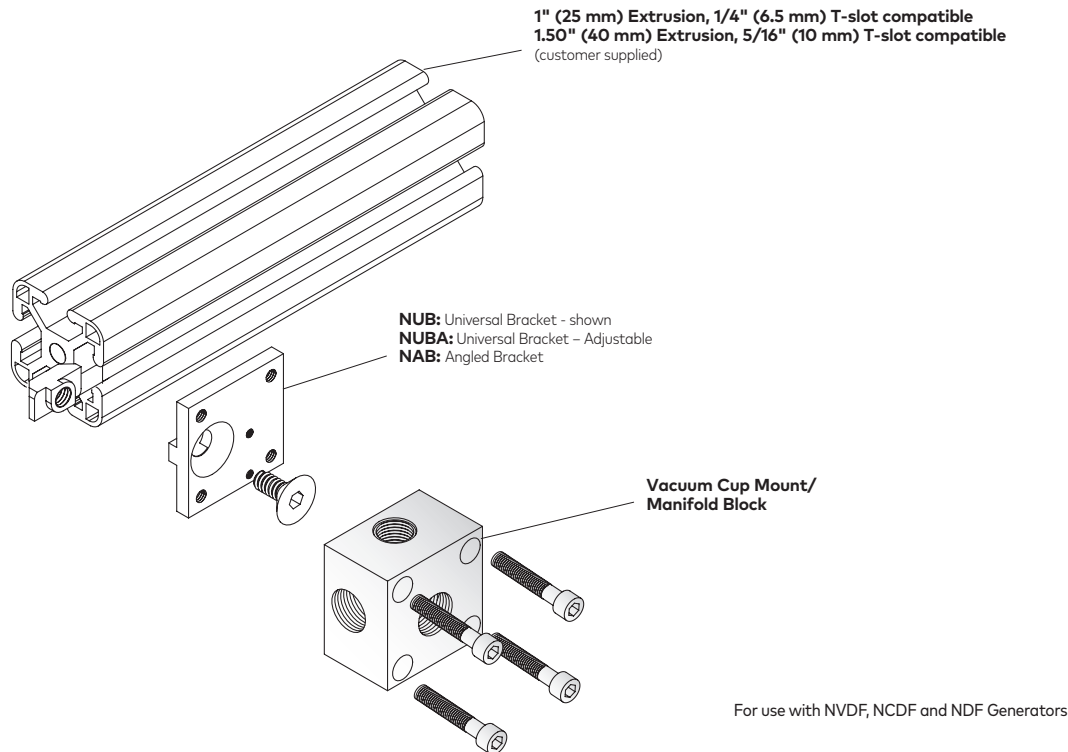

How to specify

Part Number	Vacuum Cup Mount/Manifold Block
NMB18/NMB18M-25	1/8 NPT [G1/8] - All Female Ports - recommended for 1" (25mm) extrusions
NMB14/NMB14M-40	1/4 NPT [G1/4] - All Female Ports - recommended for 1.5" (40mm) extrusions
NMBB14/NMBB14M-40	1/4 NPT [G1/4] - Bottom Male Port - recommended for 1.5" (40mm) extrusions
NMBB38/NMBB38M-40	3/8 NPT [G3/8] - Bottom Male Port - recommended for 1.5" (40mm) extrusions
NMBB12-40	1/2 NPT [G1/2] - Bottom Male Port - recommended for 1.5" (40mm) extrusions
NMBF14/NMBF14M-40	1/4 NPT [G1/4] - Face Male Port - recommended for 1.5" (40mm) extrusions
NMBF38/NMBF38M-40	3/8 NPT [G3/8] - Face Male Port - recommended for 1.5" (40mm) extrusions
NMBF12/NMBF12M-40	1/2 NPT [G1/2] - Face Male Port - recommended for 1.5" (40mm) extrusions
NMBF34/NMBF34M-40	3/4 NPT [G3/4] - Face Male Port - recommended for 1.5" (40mm) extrusions

Please note: All vacuum cup mount/manifolds include 3 flush plugs to seal extra ports.

Please order vacuum cup mount/manifolds as separate line items based on part number i.e. NMBB12-40

If you would like parts factory assembled, please specify on order "factory assembled."

To attach Vacuum Cup Mount/Manifold to extrusion, please see Universal Bracket mounting options

Vacuum Cup Mount/Manifold – All Female ports: NMB14-40, 18-25

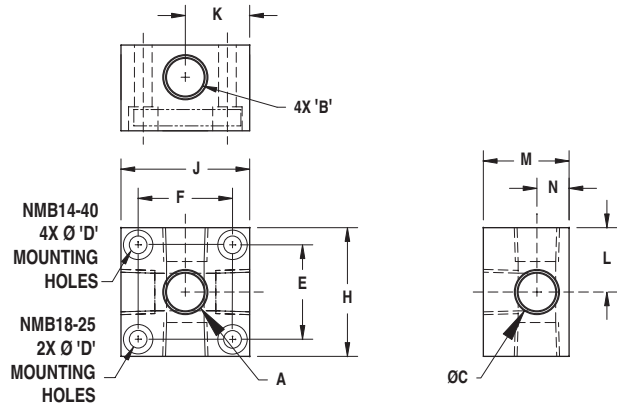
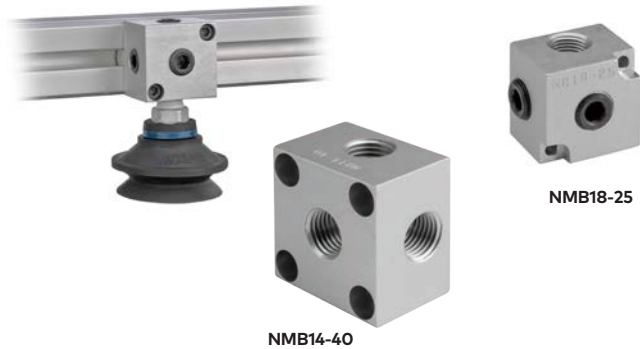

Part Number	Dimensions - Fits 1" (25 mm) Extrusions										Weight oz (g)
	A-Thread	B- Thread	C in. (mm)	D in. (mm)	E, F in. (mm)	H, J in. (mm)	K, L in. (mm)	M in. (mm)	N in. (mm)	P in. (mm)	
NMB18-25	1/8 NPT	1/8 NPT	0.34	0.10	0.75	1.00	0.50	0.75	0.25	N/A	1.2 oz
NMB18M-25	(G 1/8)	(G 1/8)	(8.6)	(3.3)	(19.1)	(25.4)	(12.7)	(19.0)	(6.4)	(N/A)	(34g)

Part Number	Dimensions - Fits 1.50" (40 mm) Extrusions										Weight oz (g)
	A-Thread	B- Thread	C in. (mm)	D in. (mm)	E, F in. (mm)	H, J in. (mm)	K, L in. (mm)	M in. (mm)	N in. (mm)	P in. (mm)	
NMB14-40	1/4 NPT	1/4 NPT	0.44	0.21	1.10	1.50	0.75	1.00	0.38	N/A	2.6 oz
NMB14M-40	(G 1/4)	(G 1/4)	(11.1)	(5.2)	(27.9)	(38.1)	(19.0)	(25.4)	(9.7)	(N/A)	(74g)

Vacuum Cup Mount/Manifold – Bottom Male ports: NMBB(14, 38, 12) -40



Can be used with NVDF, NCDF and NDF Generators. Also available in other thread sizes including 1/8 NPT (G 1/8). Consult factory.

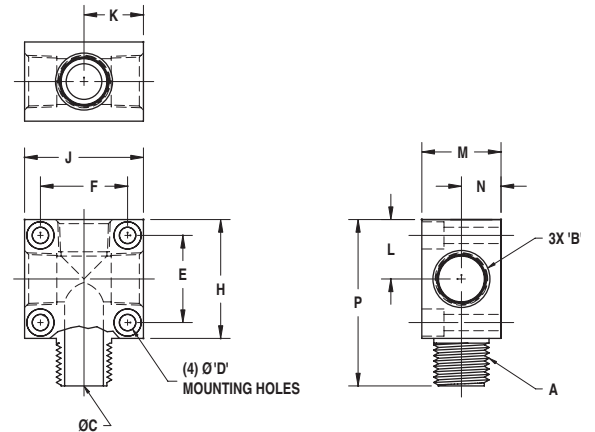
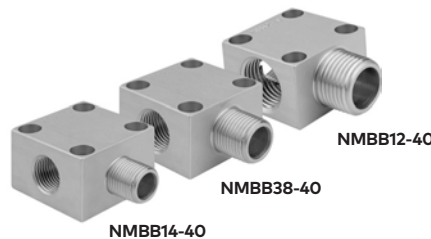

Part Number	Dimensions - Fits 1.5" [40mm] Extrusions										Weight oz (g)
	A-Thread	B- Thread	C in. (mm)	D in. (mm)	E, F in. (mm)	H, J in. (mm)	K, L in. (mm)	M in. (mm)	N in. (mm)	P in. (mm)	
NMBB14-40	1/4 NPT	1/4 NPT	0.34							2.00	2.6 oz
NMBB14M-40	(G 1/4)	(G 1/4)	(8.6)							(50.8)	(74g)
NMBB38-40	3/8 NPT	3/8 NPT	0.45	0.21	1.10	1.50	0.75	1.00	0.50	2.10	2.9 oz
NMBB38M-40	(G 3/8)	(G 3/8)	(11.4)	(5.2)	(27.9)	(38.1)	(19.0)	(25.4)	(12.7)	(53.3)	(82g)
NMBB12-40	1/2 NPT	1/2 NPT	0.58							2.10	1.9 oz
NMBB12M-40	(G 1/2)	(G 1/2)	(14.7)							(53.3)	(54g)

7 MANIFOLD BLOCKS



Vacuum Cup Mount/Manifold – Face Male Port: NMBF(14, 38, 12, 34) -40

END-OF-ARM TOOLING

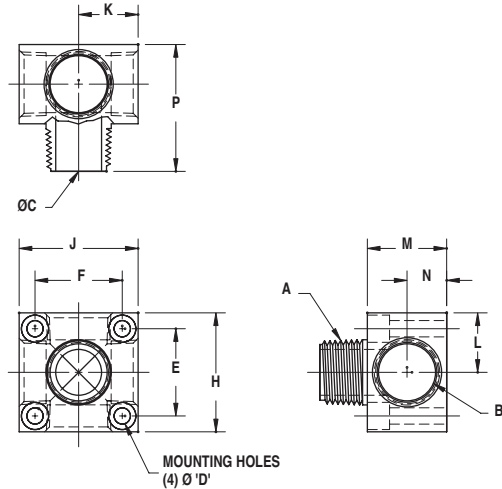
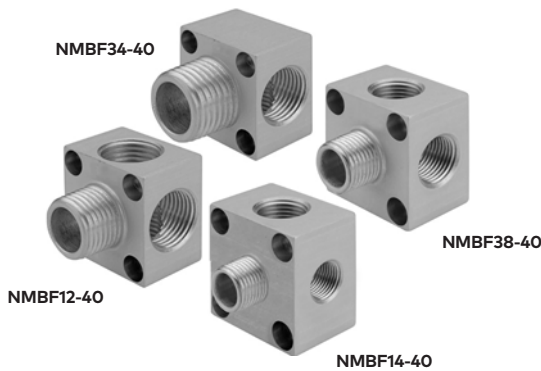

Can be used with NVDF, NCDF and NDF Generators. Also available in other thread sizes including 1/8 NPT (G 1/8). Consult factory.

Model #	Dimensions - Fits 1.5" (40 mm) Extrusions											Weight oz (g)
	A-Thread	B- Thread	C in. (mm)	D in. (mm)	E, F in. (mm)	H, J in. (mm)	K, L in. (mm)	M in. (mm)	N in. (mm)	P in. (mm)		
NMBF14-40	1/4 NPT	4 x 1/4 NPT	0.34							1.50	2.6 oz	
NMBF14M-40	(G 1/4)	(4 x G 1/4)	(8.6)							(38.1)	(74g)	
NMBF38-40	3/8 NPT	4 x 3/8 NPT	0.45							1.50	2.7 oz	
NMBF38M-40	(G 3/8)	(4 x G 3/8)	(11.4)							(38.1)	(77g)	
NMBF12-40	1/2 NPT	4 x 1/2 NPT	0.58	0.21 (5.2)	1.10 (27.9)	1.50 (38.1)	0.75 (19.0)	1.00 (25.4)	0.50 (12.7)	1.60	1.7 oz	
NMBF12M-40	(G 1/2)	(4 x G 1/2)	(14.7)							(40.6)	(48g)	
NMBF34-40	3/4 NPT	2 x 3/4 NPT	0.75							1.60	1.8 oz	
NMBF34M-40	(G 3/4)	(2 x G 3/4)	(19.1)							(40.6)	(51g)	

[Accessories]

Norgren offers a complete range of vacuum accessories to meet specific application requirements.

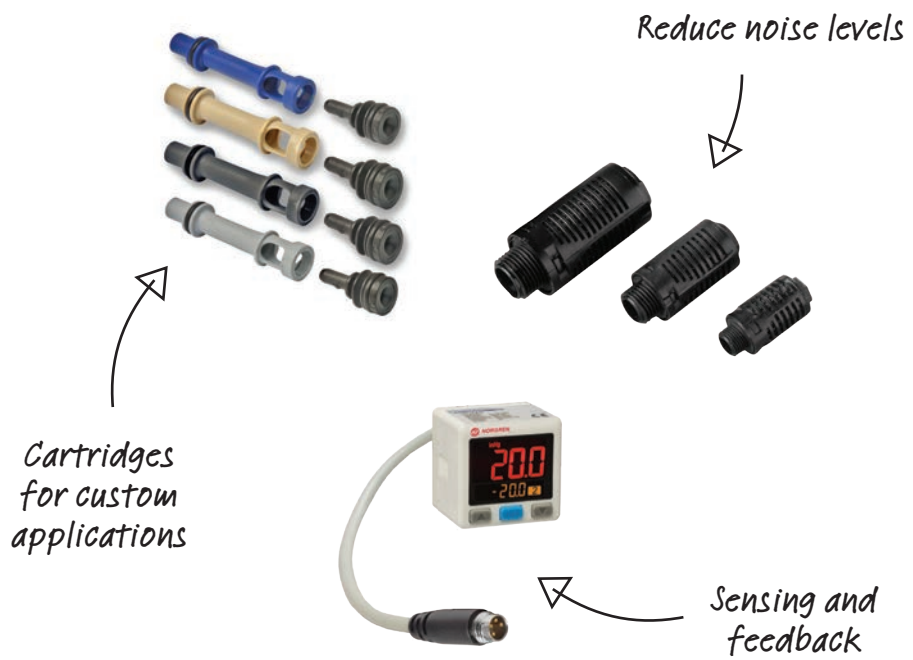



Please note: These products represent only part of the Norgren vacuum range. If you can't see the option you require please contact us.

Accessories

Cartridges

For custom vacuum applications



Page 233

Silencers

To reduce the noise of vacuum generators



Page 248

Switches/Sensors

Precision control feedback for system monitoring



Page 253

Check Valves

Check valves designed specifically for vacuum



Page 280

Gauges

Accurate monitoring of vacuum levels



Page 282

Filters

Compact in-line filters to vacuum lines



Page 284

- » Saves space – eliminates the need for an external generators, install close to vacuum point
- » High Productivity – powerful vacuum up to 28"Hg (948mbar), fast response time
- » Compact & lightweight – reduces overall equipment weight
- » Efficient – minimal air consumption, high performance
- » Straight through design – reliable, no moving parts to wear out or get clogged, no maintenance
- » Performance Optimization – precise control of flow and vacuum level

Technical Data

Fluid
Filtered (50 Micron) unlubricated, non-corrosive dry gases

Operating Pressure
80 PSI (5.5 bar) or 60 PSI (4.1 bar)

Operating Temperature
-30° to -250°F (-34° to -121°C)

Materials
Cartridge: Nylon & Buna-N O-rings

Custom Materials
Cartridge: Brass, Stainless Steel, PVC, Peek, Teflon™, Acetal
O-rings available in additional materials

Min Series Supply Line
Min. 5/32" (4mm) tube, 1/4" OD (6mm) tube preferred for lines exceeding 3' (1M)

Vacuum Line
1/4" OD (6mm) tube

Mid Series Supply Line/Vacuum Line
1/4" OD (6mm) tube for size 60 and 90
3/8" OD (10mm) tube for size 100 and 150

Max Series Supply Line/Vacuum Line
3/8" OD (10mm) tube

Performance Level Designations
"L" 0-10"Hg (0 to 339mbar) for low vacuum/high flow applications
"M" 0-20"Hg (0 to 677mbar) for medium vacuum/high flow applications
"H" 0-28"Hg (0 to 948mbar) for high vacuum/standard flow applications



Option selector

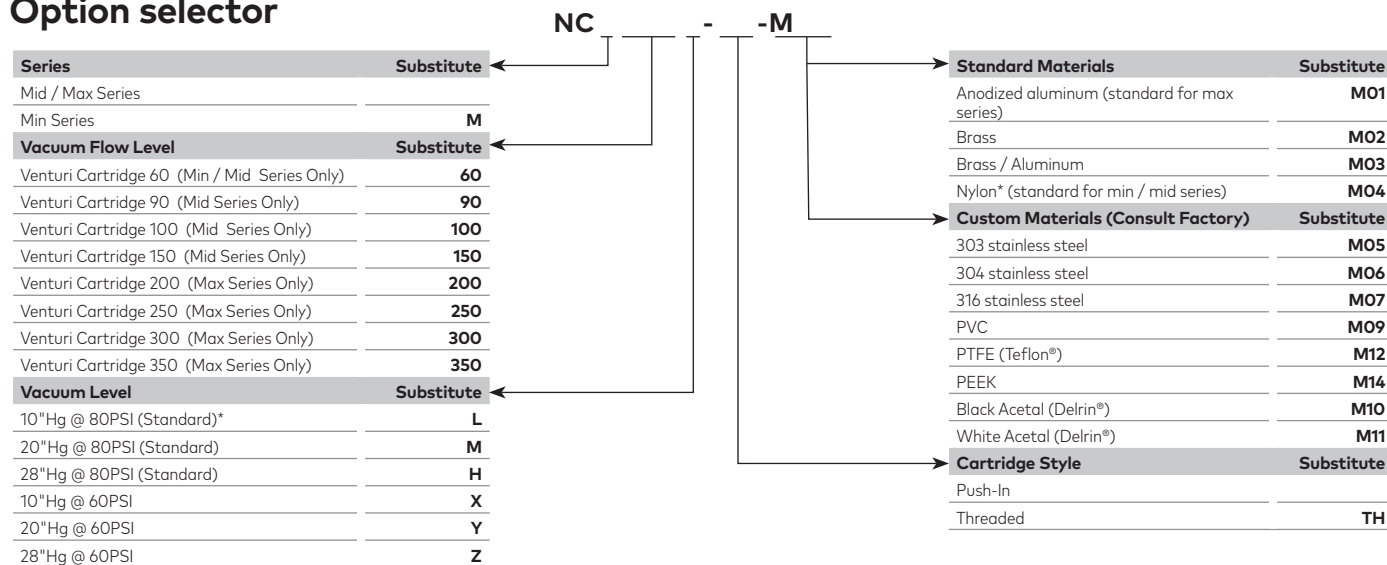

*Not available in 60 Series



Min Dimensions

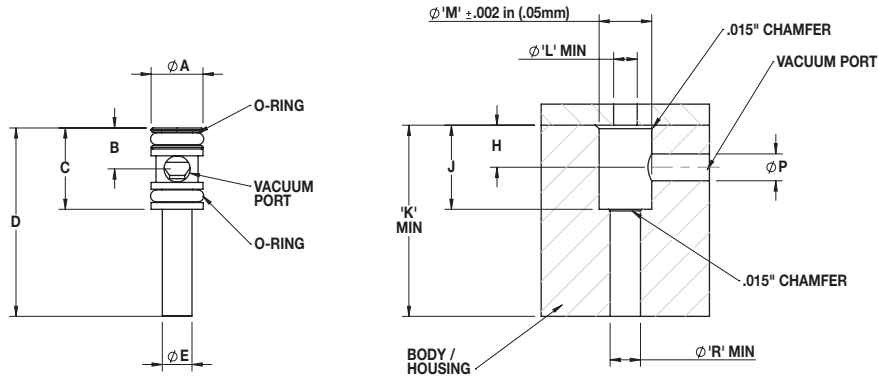

Min Series Cartridge dimensions are the same for nylon and brass

Min Series Cartridge housing

Model	Units	A	B	C	D	E	H	J	K	L	M	P	R
NCM60	Imperial	0.31	0.25	0.49	1.13	0.17							
	(Metric)	(7.9)	(6.2)	(12.3)	(28.6)	(4.3)							
Housing	Imperial						0.25	0.49	1.14	0.16	0.31	0.16	0.18
	(Metric)						(6.4)	(12.7)	(29.0)	(4.1)	(7.9)	(4.1)	(4.6)

Mid Dimensions

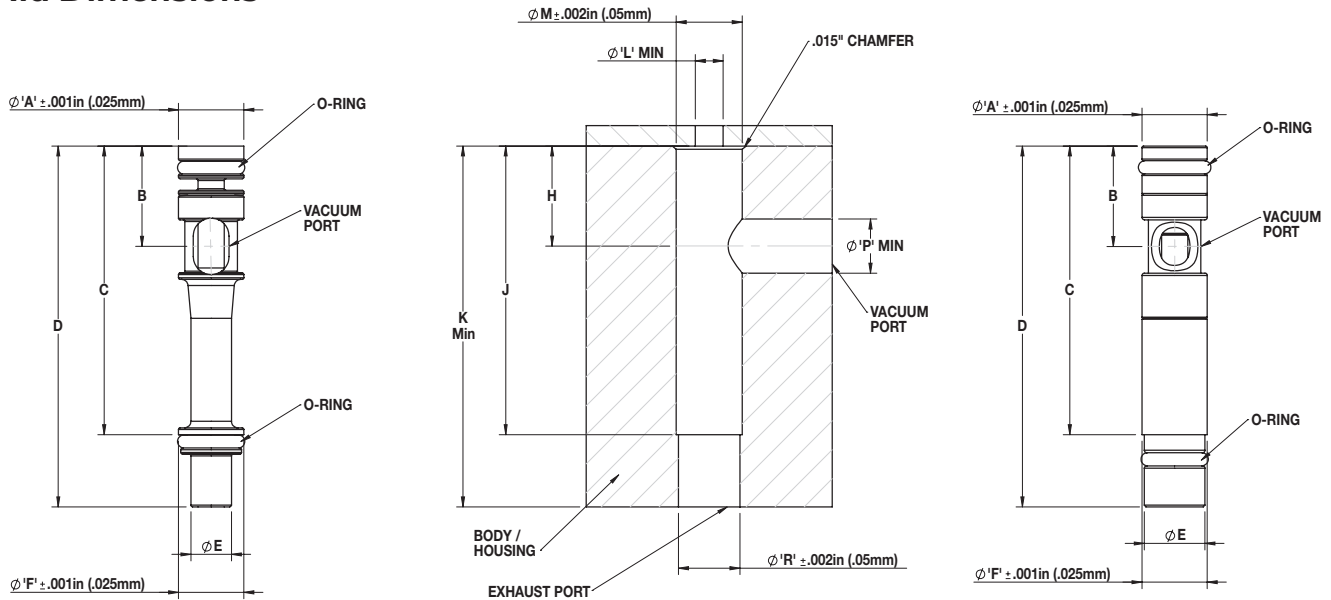

Cartridge housing for both nylon and metal cartridges

Model	Units	A	B	C	D	E	F	H	J	K	L	M	P	R
NC60, 90, 100, 150 (Nylon Cartridges)	Imperial	0.398	0.61	1.76	2.20	0.25	0.398							
	(Metric)	(10.11)	(15.5)	(44.7)	(55.9)	(6.3)	(10.1)							
NC60, 90, 100, 150 (Metal Cartridges)	Imperial	0.398	0.61	1.76	2.20	0.37	0.398							
	(Metric)	(10.11)	(15.5)	(44.7)	(55.9)	(9.4)	(10.1)							
Housing	Imperial							0.61	1.78	2.21	0.14	0.40	0.33	0.38
	(Metric)							(15.5)	(45.1)	(56.1)	(3.6)	(10.2)	(8.3)	(9.7)

Mid Series Identification Chart

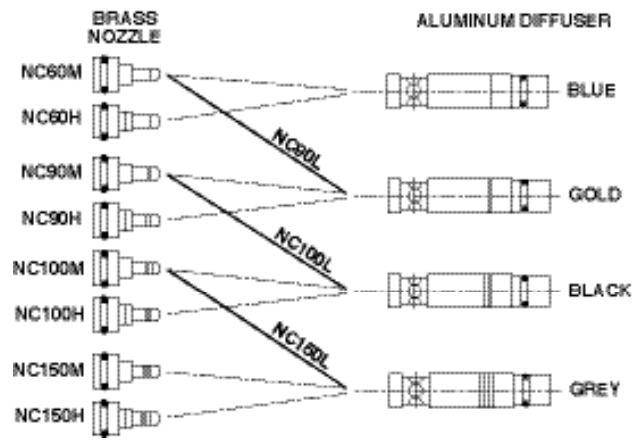
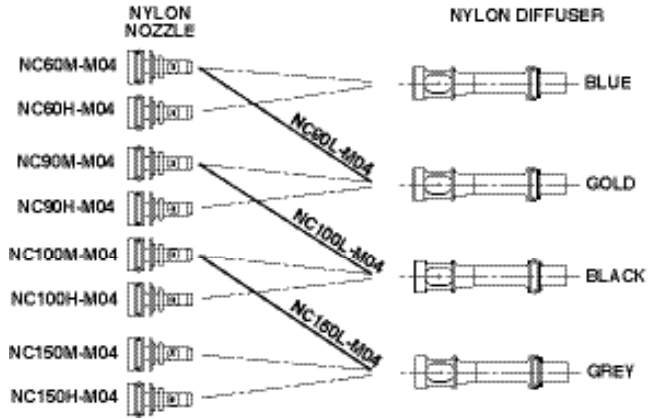



Mid - Threaded Dimensions

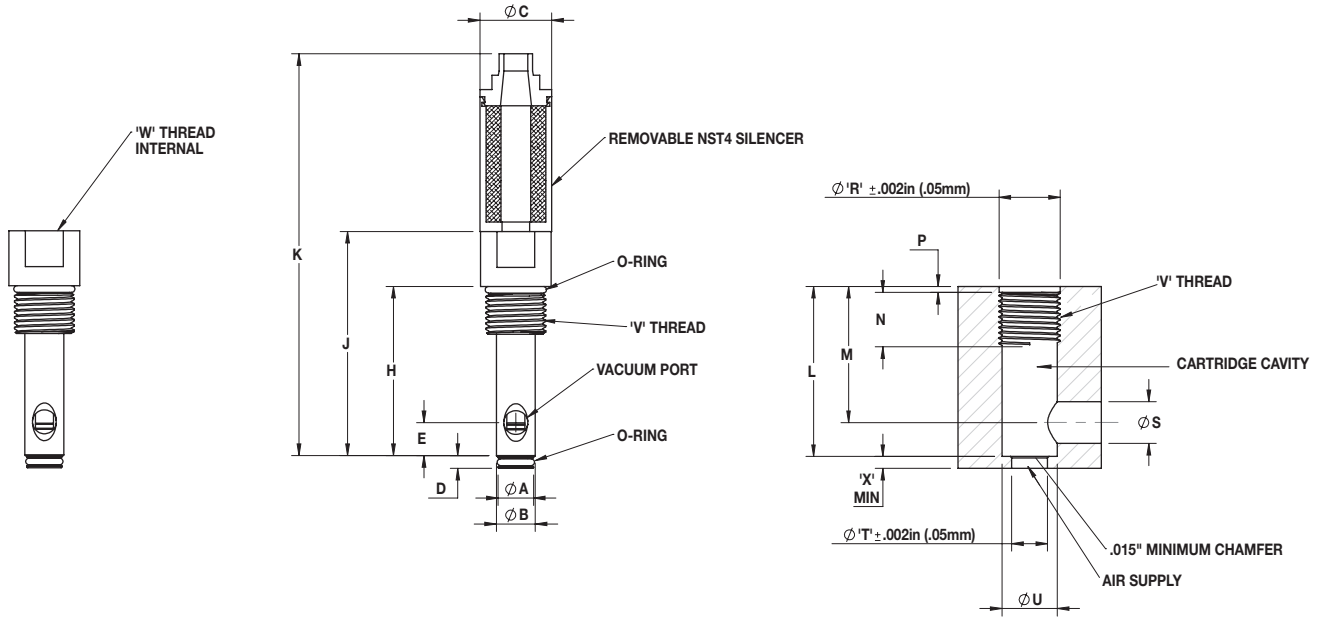

NC60*-150*-TH	Units	A	B	C	D	E	H	J	K	L	M	N	P	R	S	T	U	V	W	X
Cartridge	Imperial	0.37	0.41	0.75	0.13	0.36	1.78	2.36	4.22									5/8-18 UNF	1/4-18 NPS	
	(Metric)	(9.4)	(10.7)	(19.1)	(3.2)	(9.1)	(45.2)	(59.9)	(107.1)									(M16x1.5)	(1/4-18 NPS)	
Cavity	Imperial									1.78	1.43	0.63	0.06	0.64	0.44	0.38	0.58	(5/8-18 UNF)	-	0.13
	(Metric)									(45.2)	(36.3)	(16.0)	(1.6)	(16.3)	(11.1)	(9.5)	(14.5)	(M16x1.5)	-	(3.3)

Max - Threaded Dimensions

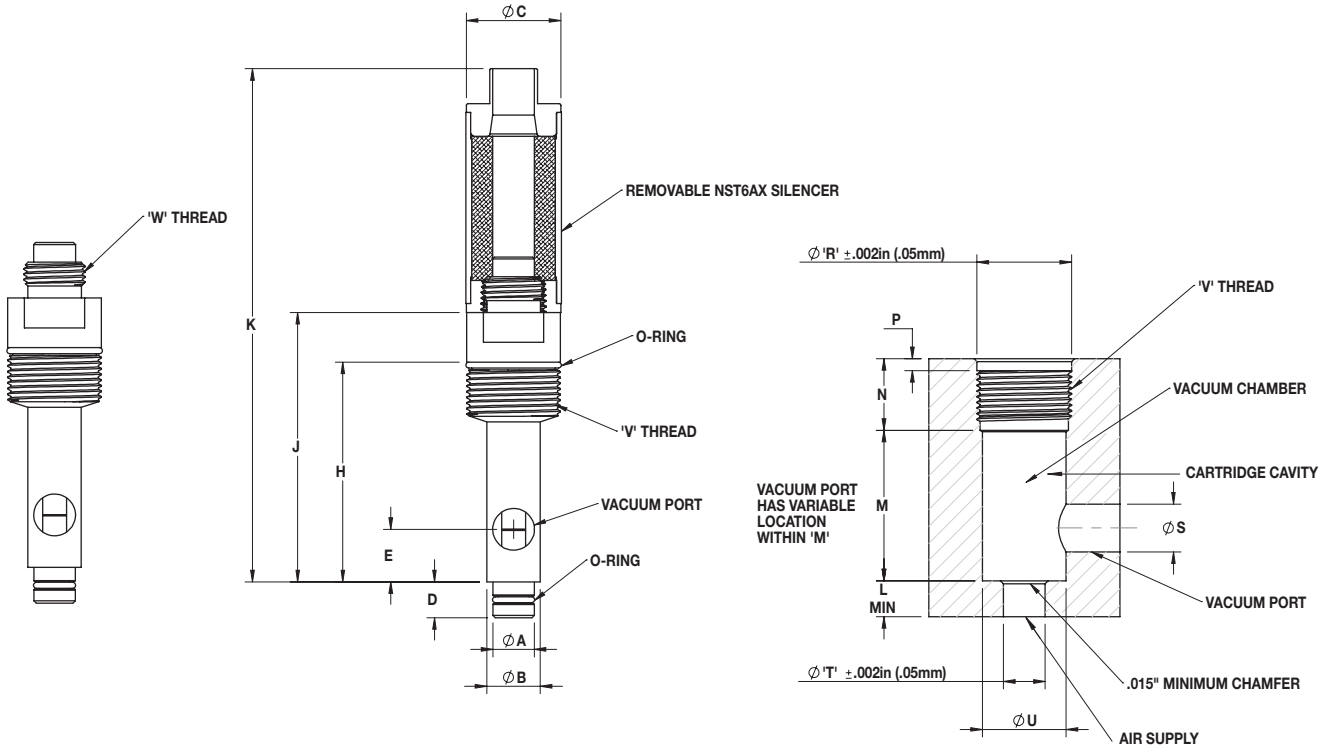

NC200*-250*-TH	Units	A	B	C	D	E	H	J	K	L	M	N	P	R	S	T	U	V	W
Cartridge	Imperial	0.43	0.56	1.00	0.38	0.55	2.30	2.82	5.37									7/8-20 UNEF	3/8-18 NPS
	(Metric)	(11.0)	(14.2)	(25.4)	(9.7)	(14.0)	(58.4)	(71.6)	(136.4)									(M25x1.5)	(3/8-18 NPS)
Cavity	Imperial									0.38	1.58	0.75	0.13	0.99	0.50	0.44	0.63	7/8-20 UNEF	-
	(Metric)									(9.7)	(40.1)	(19.1)	(3.3)	(25.2)	(12.7)	(11.2)	(16.0)	(M25x1.5)	-



Max - Threaded Dimensions

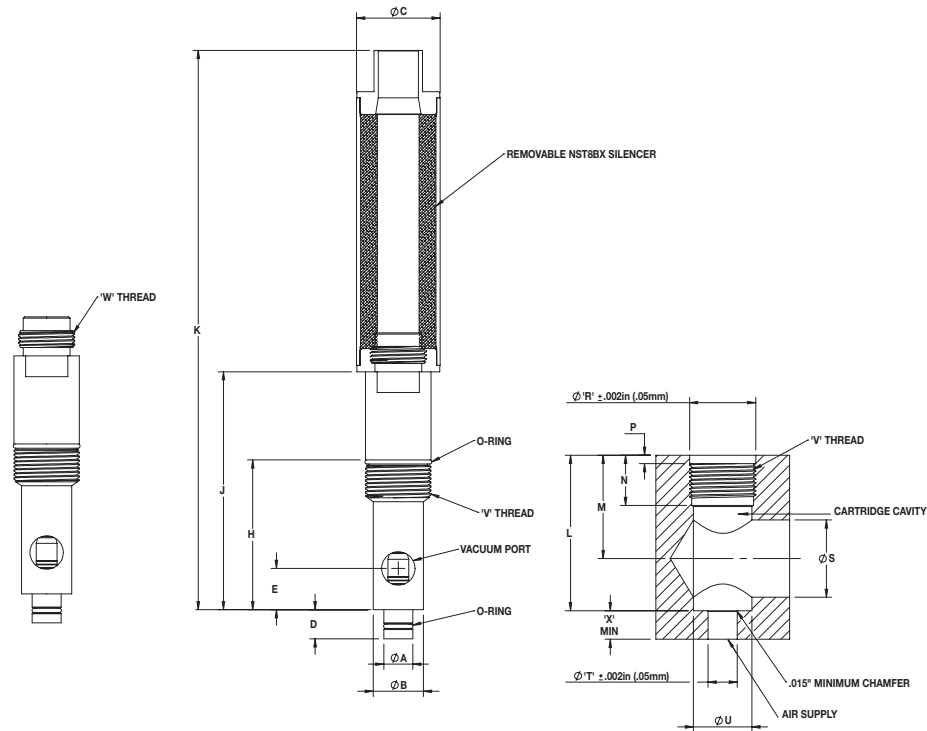

NC300*- 350*-TH	Units	A	B	C	D	E	H	J	K	L	M	N	P	R	S	T	U	V	W	X
Cartridge	Imperial	0.43	0.75	1.25	0.44	0.62	2.24	3.56	8.36									7/8-20 UNEF	1/2-14 NPS	
	(Metric)	(11.0)	(19.1)	(31.8)	(11.2)	(15.7)	(56.9)	(90.4)	(212.4)									(M25x1.5)	(1/2-14 NPS)	
Cavity	Imperial									2.33	1.55	0.75	0.13	0.99	1.16	0.44	0.81	7/8-20 UNEF	-	0.44
	(Metric)									(59.1)	(39.2)	(19.1)	(3.2)	(25.2)	(29.4)	(11.1)	(20.6)	(M25x1.5)	-	(22.0)

NC-MSR SERIES

Threaded Cartridge

- » Maintenance Free - straight through design allows debris to pass through without clogging
- » No downtime - screws directly into existing multi-stage generators
- » Efficient - minimal air consumption
- » Performance Optimization - precise control of vacuum and flow levels
- » Direct Replacement - no plumbing, no tools required, change in minutes

Technical Data

Fluid
Filtered (50 Micron)
unlubricated, non-corrosive dry gases

Operating Temperature
-30° to ~250° F (-34° to ~121°C)

Operating Pressure
80 PSI (5.5 bar) Standard or
60 PSI (4.1 bar)

Materials
Generator Body: Anodized
Aluminum

Recommended Supply Line
M07 1/4" (6mm) OD
M14 3/8" (10mm) OD
M25 1/2" (12mm) OD

Recommended Vacuum Port
M07 1/8 NPTF (G1/8 F)
M14 3/8 NPTF (G1/2 F)
M25 1/2 NPTF (G1/2 F)



Standard Models

Part Number	Max. Vacuum Level	Max. Vacuum Flow	Air Consumption
NCM60H1-M07-MSR-M01	28.0	0.8	0.8
NCM60M1-M07-MSR-M01	20.0	0.5	0.5
NC060H1-M14-MSR-M01	28.0	0.8	0.8
NC060M1-M14-MSR-M01	20.0	0.5	0.5
NC090H1-M14-MSR-M01	28.0	1.2	1.8
NC090M1-M14-MSR-M01	20.0	1.4	1.4
NC150H1-M14-MSR-M01	28.0	3.2	4.8
NC150M1-M14-MSR-M01	20.0	3.5	2.8
NC200H1-M25-MSR-M01	28.0	5.4	7.8
NC200M1-M25-MSR-M01	20.0	6.0	4.8
NC250H1-M25-MSR-M01	28.0	9.0	12.5
NC250M1-M25-MSR-M01	20.0	9.5	7.8
NC300M1-M25-MSR-M01	20.0	20.0	12.5
NC350M1-M25-MSR-M01	20.0	28.0	22.0

Option selector

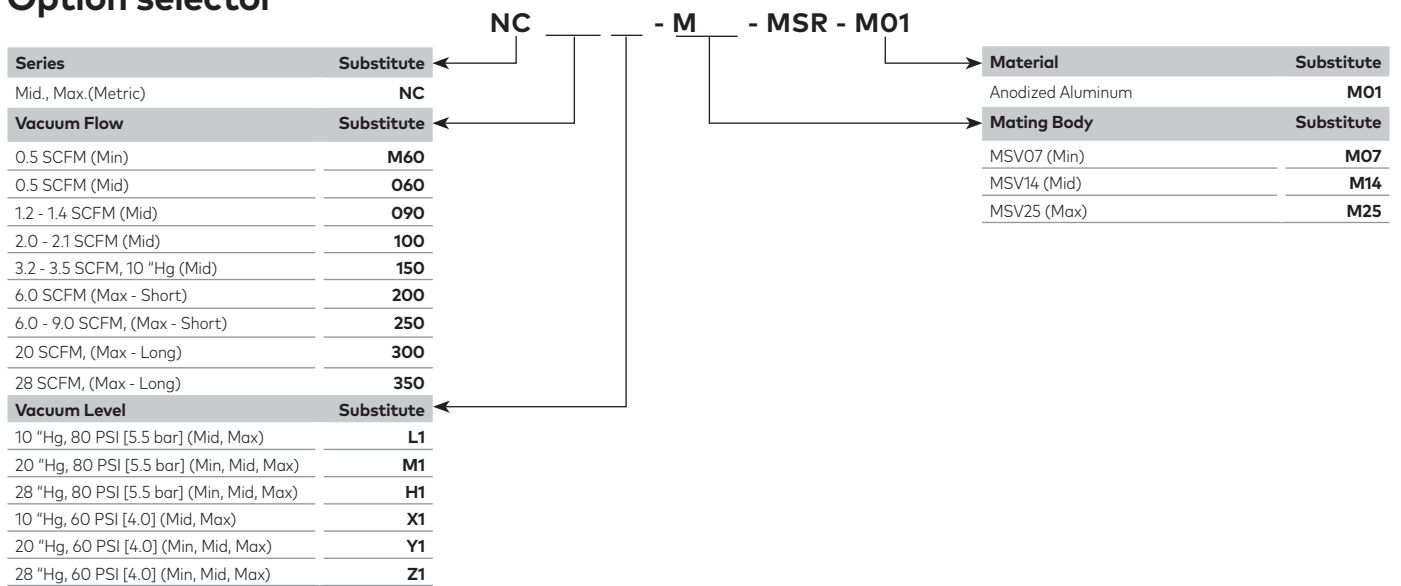

NC-MSR SERIES

(M07-MSR) Threaded Cartridge



Dimensions inches (mm)

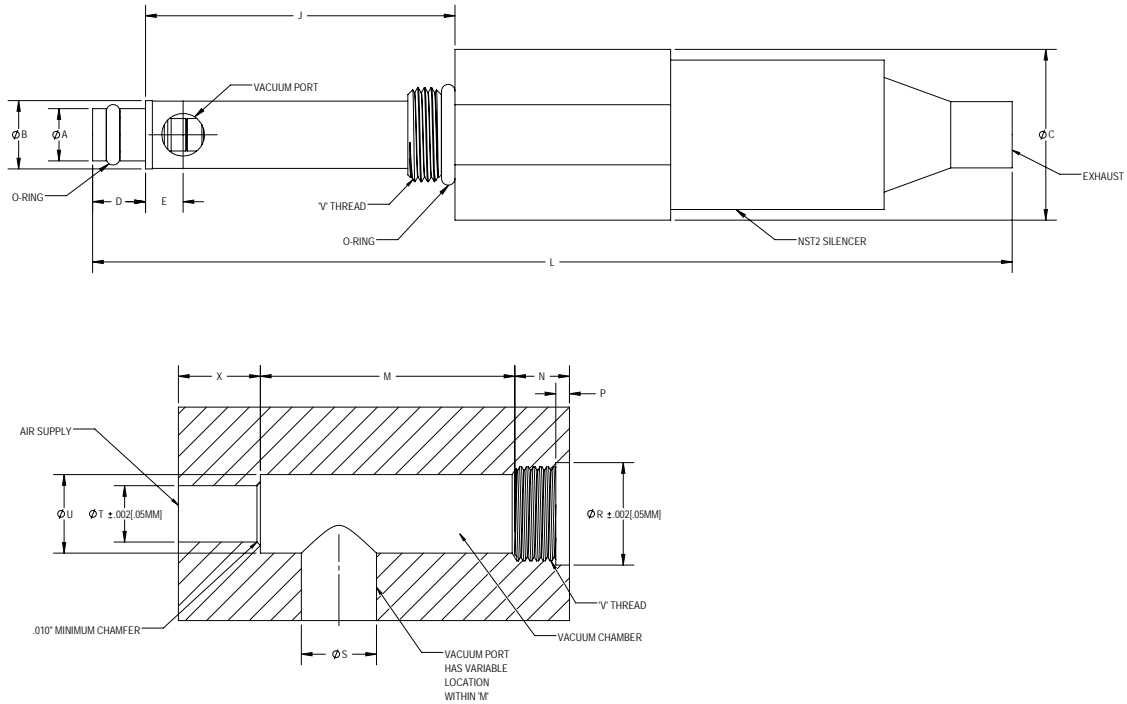

Model	Units	A	B	C	D	E	J	L	M	N	P	R	S	T	U	V	X
NCM60X1-M07-MSR	Imperial	0.15	0.20	0.50	0.16	0.11	0.91	4.43	1.58	0.75	0.90	0.99	0.70	0.44	0.88	M7 x 0.5	N/A
CAVITY	Imperial	N/A	N/A	N/A	N/A	N/A	N/A	N/A	0.75	0.16	0.04	0.30	0.22	0.17	0.23	M07 X 0.5	0.24
NCM60X1-M07-MSR	(Metric)	(3.8)	(5.1)	(12.7)	(4.1)	(2.8)	(23.1)	(112.5)	(40.1)	(19.1)	(22.9)	(25.1)	(17.8)	(11.2)	(22.4)	(M7 x 0.5)	(N/A)
CAVITY	(Metric)	N/A	N/A	N/A	N/A	N/A	N/A	N/A	(19.1)	(4.1)	(1.0)	(7.6)	(5.6)	(4.3)	(5.8)	(M07 X 0.5)	(6.1)

NC-MSR SERIES

(M14-MSR) Threaded Cartridge



Dimensions inches (mm)

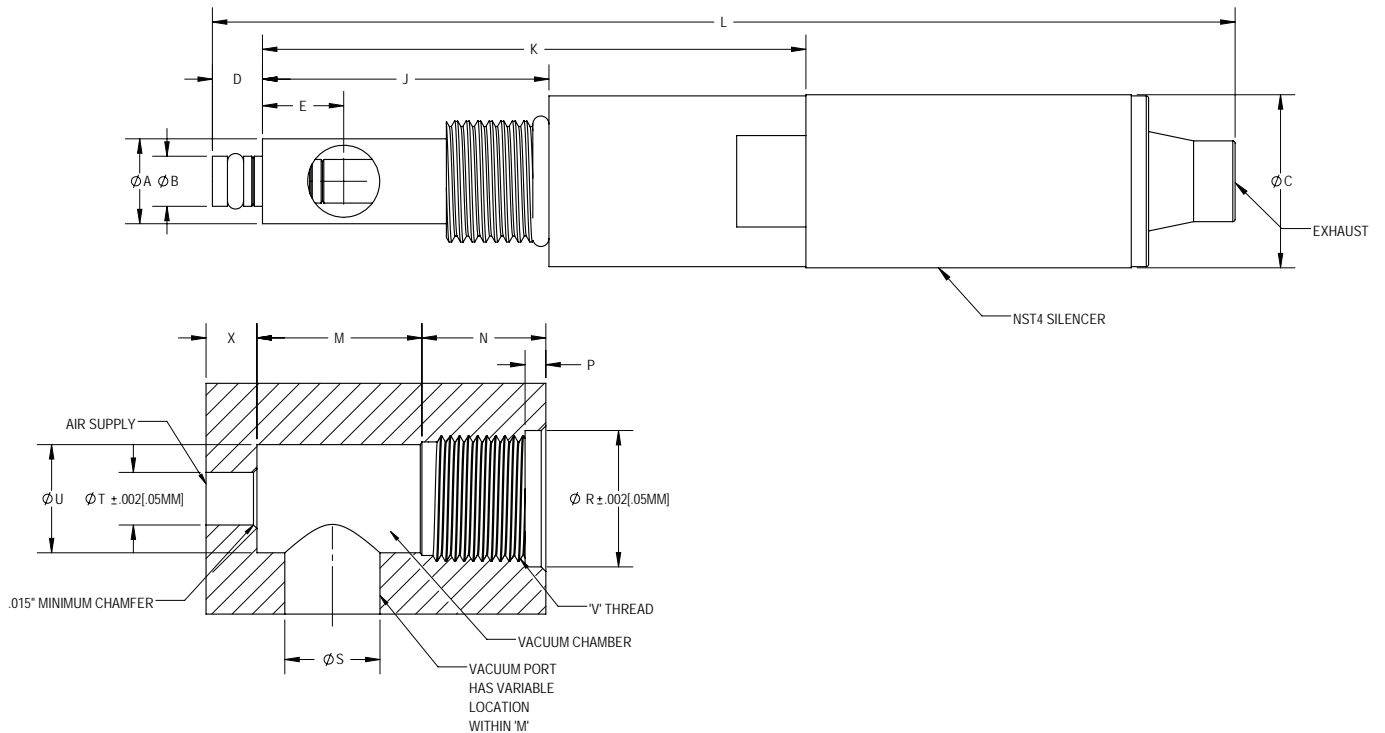

Model	Units	A	B	C	D	E	J	K	L	M	N	P	R	S	T	U	V	X
NCXXX1-M14-MSR	Imperial	0.22	0.37	0.75	0.22	0.35	1.24	2.36	4.43	1.58	0.75	0.90	0.99	0.70	0.44	0.88	M14 x 1.0	N/A
CAVITY	Imperial	N/A	N/A	N/A	N/A	N/A	N/A	N/A	N/A	0.72	0.54	0.09	0.59	0.41	0.23	0.47	M14 X 1.0	0.22
NCXXX1-M14-MSR	(Metric)	(5.6)	(9.4)	(19.1)	(5.6)	(8.9)	(31.5)	(59.9)	(112.5)	(40.1)	(19.1)	(22.9)	(25.1)	(17.8)	(11.2)	(22.4)	(M14 x 1.0)	(N/A)
CAVITY	(Metric)	(N/A)	(N/A)	(N/A)	(N/A)	(N/A)	(N/A)	(N/A)	N/A	(38.4)	(20.1)	(2.3)	(25.2)	(17.8)	(11.4)	(22.4)	M25 X 1.5	(5.6)

NC-MSR SERIES

(M25-MSR) Threaded Cartridge



Dimensions inches (mm)

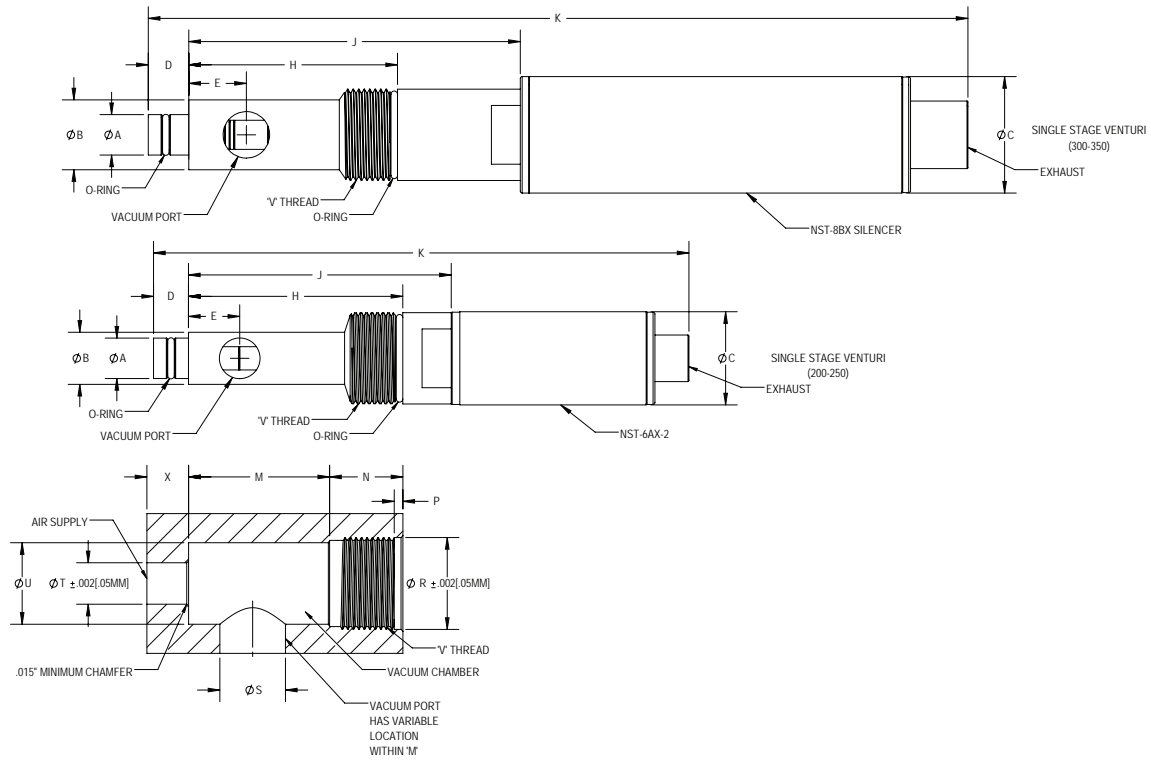

Model	Units	A	B	C	D	E	H	J	K	L	M	N	P	R	S	T	U	V	X
NC2XXX1-M25-MSR	Imperial	0.43	0.56	1.00	0.38	0.55	2.30	2.82	5.37	0.45	1.58	0.75	0.90	0.99	0.70	0.44	0.88	M25 x 1.5	N/A
NC3XXX1-M25-MSR	Imperial	0.43	0.75	1.25	0.43	0.62	2.30	3.56	8.36	0.45	1.58	0.75	0.90	0.99	0.70	0.44	0.88	M25 x 1.5	N/A
CAVITY	Imperial	N/A	N/A	N/A	N/A	N/A	N/A	N/A	N/A	N/A	1.51	0.79	0.09	0.99	0.70	0.45	0.88	M25 X 1.5	0.45
NC2XXX1-M25-MSR	(Metric)	(10.9)	(14.2)	(25.4)	(9.7)	(14.0)	(58.4)	(71.6)	(136.4)	(11.4)	(40.1)	(19.1)	(22.9)	(25.1)	(17.8)	(11.2)	(22.4)	(M25 x 1.5)	(N/A)
NC3XXX1-M25-MSR	(Metric)	(10.9)	(19.1)	(31.8)	(10.9)	(15.7)	(58.4)	(90.4)	(212.3)	(11.4)	(40.1)	(19.1)	(22.9)	(25.1)	(17.8)	(11.2)	(22.4)	(M25 x 1.5)	(N/A)
CAVITY	(Metric)	(N/A)	(N/A)	(N/A)	(N/A)	(N/A)	(N/A)	(N/A)	(N/A)	(N/A)	(38.4)	(20.1)	(2.3)	(25.2)	(17.8)	(11.4)	(22.4)	(M25 X 1.5)	(5.6)

Performance Data - Min Series

Model	Air Consumption SCFM (L/min)	Vacuum Level "Hg (mbar)	0"Hg (0)	3"Hg (102)	6"Hg (203)	9"Hg (305)	12"Hg (406)	15"Hg (508)	18"Hg (609)	20"Hg (677)	21"Hg (711)	24"Hg (813)	27"Hg (914)	28"Hg (948)
60M	0.50 (14.2)	Vacuum Flow SCFM (L/min)	0.50 (14.2)	0.40 (11.3)	0.30 (8.5)	0.22 (6.2)	0.15 (4.2)	0.08 (2.3)	0.03 (0.8)	0.00 (0.0)	- (-)	- (-)	- (-)	- (-)
		Evacuation time (seconds)	0.00 (0.0)	12.50 (0.4)	25.10 (0.9)	43.90 (1.6)	68.60 (2.4)	99.30 (3.5)	153.70 (5.4)	227 (8.0)	- (-)	- (-)	- (-)	- (-)
60H	0.80 (22.7)	Vacuum Flow SCFM (L/min)	0.50 (14.2)	0.38 (10.8)	0.32 (9.1)	0.30 (8.5)	0.27 (7.6)	0.23 (6.5)	0.20 (5.7)	- (-)	0.13 (3.7)	0.05 (1.4)	0.02 (0.6)	0.00 (0.0)
		Evacuation time (seconds)	0.00 (0.0)	15.00 (0.5)	29.80 (1.1)	50.60 (1.8)	74.50 (2.6)	102.80 (3.6)	135.90 (4.8)	- (-)	182.20 (6.5)	245.90 (8.7)	410.20 (14.5)	790.80 (27.9)

Evacuation time in seconds based on 1 cubic foot volume / "Hg (1 Liter Volume / mbar)

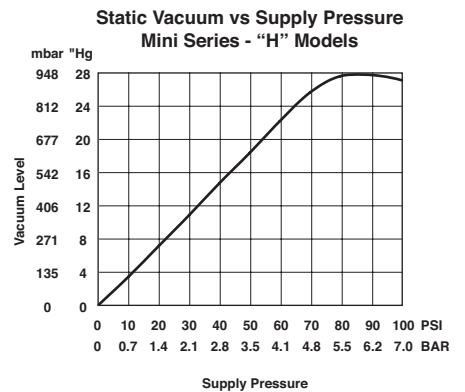
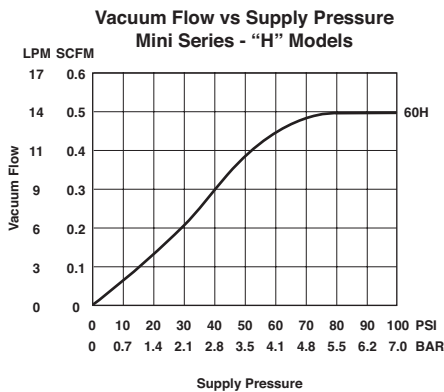
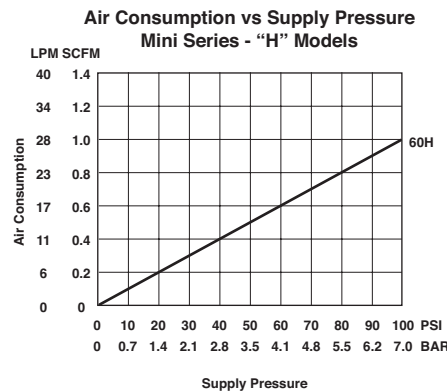
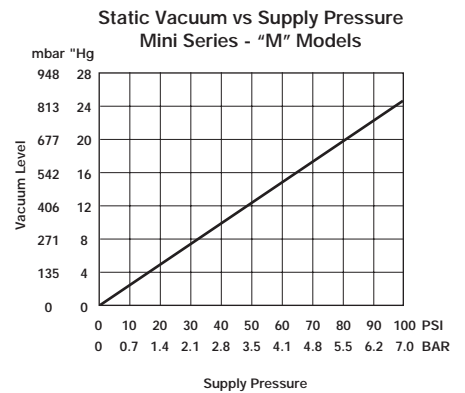
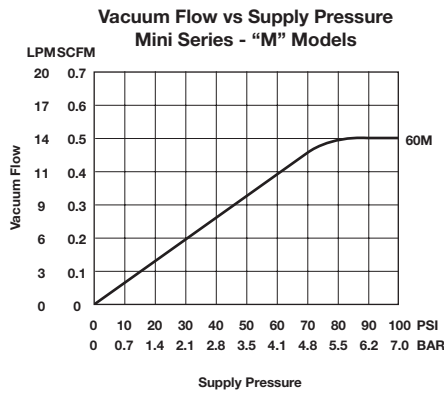
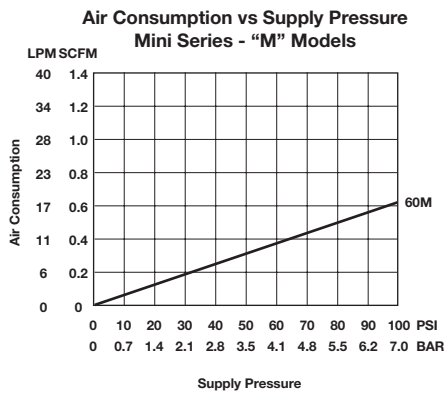

Notes: Standard operating pressure for Norgren generators is 80 PSI [5.5 bar]. Generators can be factory modified to run at other operating pressures i.e. 60 PSI [4.1 bar] etc. The values shown in the performance chart will remain the same for all operating pressures.



Performance Data - Mid Series

Model	Air Consumption SCFM (L/min)	Vacuum Level "Hg (mbar)	0"Hg (0)	3"Hg (102)	6"Hg (203)	9"Hg (305)	10"Hg (339)	12"Hg (406)	15"Hg (508)	18"Hg (609)	20"Hg (677)	21"Hg (711)	24"Hg (813)	27"Hg (914)	28"Hg (948)
90L	0.50 (14.2)	Vacuum Flow SCFM (L/min)	1.30 (36.8)	1.10 (31.1)	0.70 (19.8)	0.20 (5.7)	0.00 (0.00)	- (-)	- (-)	- (-)	- (-)	- (-)	- (-)	- (-)	- (-)
		Evacuation time (seconds)	0.00 (0.0)	3.26 (0.1)	7.93 (0.3)	18.65 (0.7)	39.63 (1.40)	- (-)	- (-)	- (-)	- (-)	- (-)	- (-)	- (-)	- (-)
100L	1.40 (39.6)	Vacuum Flow SCFM (L/min)	2.10 (59.5)	1.60 (45.3)	1.10 (31.1)	0.50 (14.2)	0.00 (0.00)	- (-)	- (-)	- (-)	- (-)	- (-)	- (-)	- (-)	- (-)
		Evacuation time (seconds)	0.00 (0.0)	2.33 (0.1)	4.66 (0.2)	10.88 (0.4)	24.00 (0.90)	- (-)	- (-)	- (-)	- (-)	- (-)	- (-)	- (-)	- (-)
150L	1.80 (51.0)	Vacuum Flow SCFM (L/min)	3.50 (99.1)	2.50 (70.8)	1.90 (53.8)	0.70 (19.8)	0.00 (0.00)	- (-)	- (-)	- (-)	- (-)	- (-)	- (-)	- (-)	- (-)
		Evacuation time (seconds)	0.00 (0.0)	1.54 (0.1)	4.36 (0.2)	10.77 (0.4)	22.83 (0.80)	- (-)	- (-)	- (-)	- (-)	- (-)	- (-)	- (-)	- (-)
60M	0.50 (14.2)	Vacuum Flow SCFM (L/min)	0.50 (14.2)	0.40 (11.3)	0.30 (8.5)	0.22 (6.2)	- (-)	0.15 (4.2)	0.08 (2.3)	0.03 (0.8)	0.00 (0.0)	- (-)	- (-)	- (-)	- (-)
		Evacuation time (seconds)	0.00 (0.0)	12.50 (0.4)	25.10 (0.9)	43.90 (1.6)	- (-)	68.60 (2.4)	99.30 (3.5)	153.70 (5.4)	227.00 (8.0)	- (-)	- (-)	- (-)	- (-)
90M	1.40 (39.6)	Vacuum Flow SCFM (L/min)	1.40 (39.6)	1.25 (35.4)	1.20 (34.0)	1.05 (29.7)	- (-)	0.85 (24.1)	0.65 (18.4)	0.25 (7.1)	0.00 (0.0)	- (-)	- (-)	- (-)	- (-)
		Evacuation time (seconds)	0.00 (0.0)	3.75 (0.1)	7.20 (0.3)	12.40 (0.4)	- (-)	19.10 (0.7)	29.90 (1.1)	52.00 (1.8)	104.00 (3.7)	- (-)	- (-)	- (-)	- (-)
100M	1.80 (51.0)	Vacuum Flow SCFM (L/min)	2.10 (59.5)	2.00 (56.6)	1.85 (52.4)	1.75 (49.6)	- (-)	1.60 (45.3)	1.25 (35.4)	0.80 (22.7)	0.00 (0.0)	- (-)	- (-)	- (-)	- (-)
		Evacuation time (seconds)	0.00 (0.0)	2.65 (0.1)	5.80 (0.2)	9.90 (0.3)	- (-)	16.20 (0.6)	22.90 (0.8)	36.20 (1.3)	56.60 (2.0)	- (-)	- (-)	- (-)	- (-)
150M	2.80 (79.3)	Vacuum Flow SCFM (L/min)	3.50 (99.1)	3.20 (90.6)	2.95 (83.5)	2.75 (77.9)	- (-)	2.50 (70.8)	1.80 (51.0)	0.95 (26.9)	0.00 (0.0)	- (-)	- (-)	- (-)	- (-)
		Evacuation time (seconds)	0.00 (0.0)	1.35 (0.0)	3.20 (0.1)	5.20 (0.2)	- (-)	7.70 (0.3)	11.80 (0.4)	23.40 (0.8)	52.00 (1.8)	- (-)	- (-)	- (-)	- (-)
60H	0.80 (22.7)	Vacuum Flow SCFM (L/min)	0.50 (14.2)	0.38 (10.8)	0.32 (9.1)	0.30 (8.5)	- (-)	0.27 (7.6)	0.23 (6.5)	0.20 (5.7)	- (-)	0.13 (3.7)	0.05 (1.4)	0.02 (0.6)	0.00 (0.0)
		Evacuation time (seconds)	0.00 (0.0)	15.00 (0.5)	29.80 (1.1)	50.60 (1.8)	- (-)	74.50 (2.6)	102.80 (3.6)	135.90 (4.8)	- (-)	183.20 (6.5)	245.90 (8.7)	410.20 (14.5)	790.80 (27.9)
90H	1.80 (51.0)	Vacuum Flow SCFM (L/min)	1.20 (34.0)	1.00 (28.3)	0.95 (26.9)	0.90 (25.5)	- (-)	0.85 (24.1)	0.75 (21.2)	0.70 (19.8)	- (-)	0.52 (14.7)	0.47 (13.3)	0.20 (5.7)	0.00 (0.0)
		Evacuation time (seconds)	0.00 (0.0)	6.50 (0.2)	12.30 (0.4)	18.90 (0.7)	- (-)	32.50 (1.1)	47.00 (1.7)	65.40 (2.3)	- (-)	92.20 (3.3)	130.00 (4.6)	222.20 (7.8)	281.30 (9.9)
100H	2.80 (79.3)	Vacuum Flow SCFM (L/min)	2.00 (56.6)	1.85 (52.4)	1.75 (49.6)	1.57 (44.5)	- (-)	1.40 (39.6)	1.25 (35.4)	1.05 (29.7)	- (-)	0.84 (23.8)	0.70 (19.8)	0.35 (9.9)	0.00 (0.0)
		Evacuation time (seconds)	0.00 (0.0)	2.70 (0.1)	6.50 (0.2)	11.20 (0.4)	- (-)	17.50 (0.6)	25.80 (0.9)	38.40 (1.4)	- (-)	55.20 (1.9)	79.20 (2.8)	166.70 (5.9)	251.80 (8.9)
150H	4.80 (135.9)	Vacuum Flow SCFM (L/min)	3.20 (90.6)	2.80 (79.3)	2.50 (70.8)	2.30 (65.1)	- (-)	2.00 (56.6)	1.60 (45.3)	1.40 (39.6)	- (-)	1.20 (34.0)	0.80 (22.7)	0.50 (14.6)	0.00 (0.0)
		Evacuation time (seconds)	0.00 (0.0)	2.30 (0.1)	3.80 (0.1)	6.50 (0.2)	- (-)	10.20 (0.3)	14.20 (0.5)	21.30 (0.8)	- (-)	44.90 (1.6)	55.00 (1.9)	81.00 (2.9)	125.00 (4.4)

Evacuation time in seconds based on 1 cubic foot volume / "Hg (1 Liter Volume / mbar)

Performance Data - Mid Series

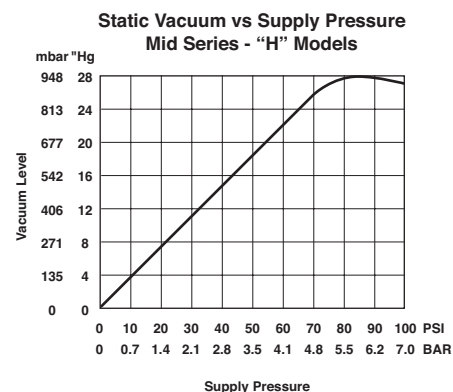
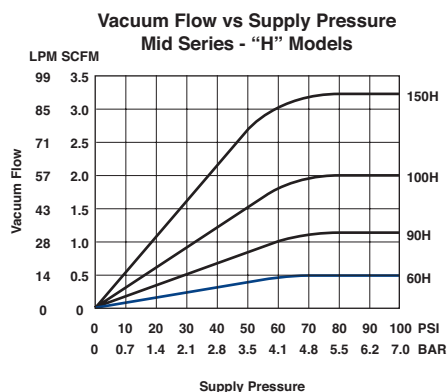
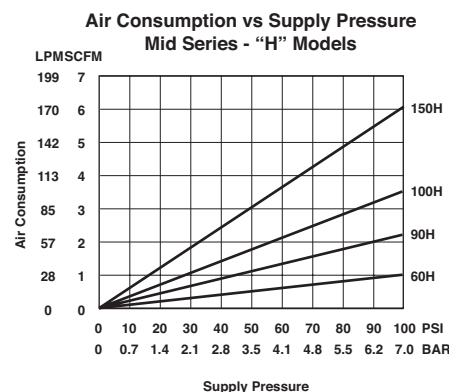
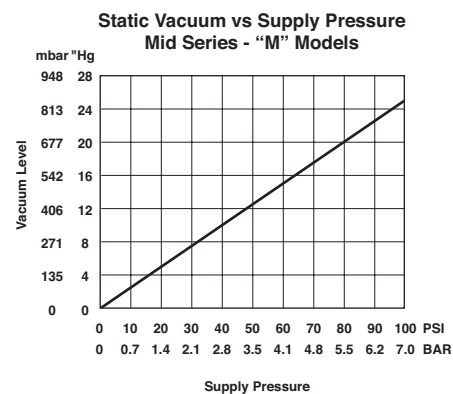
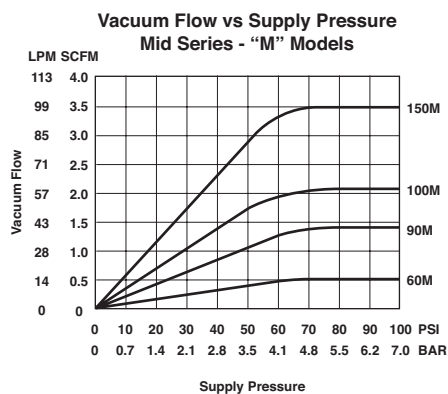
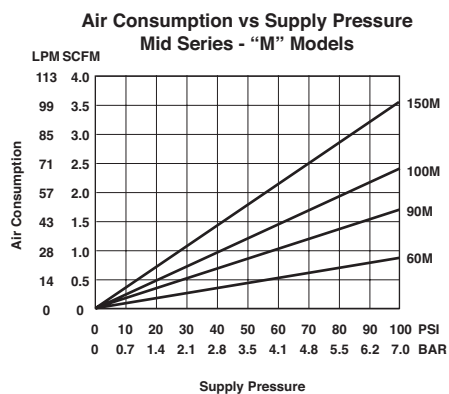
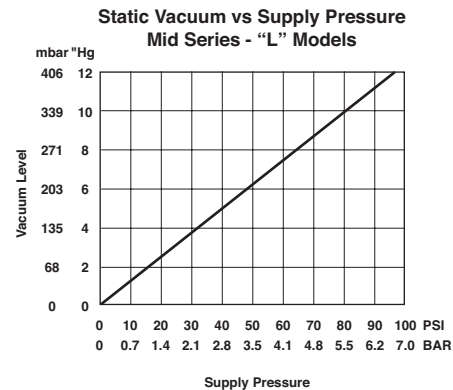
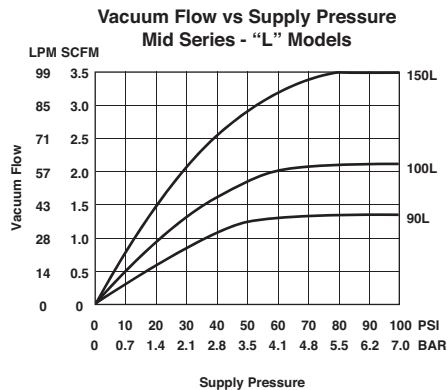
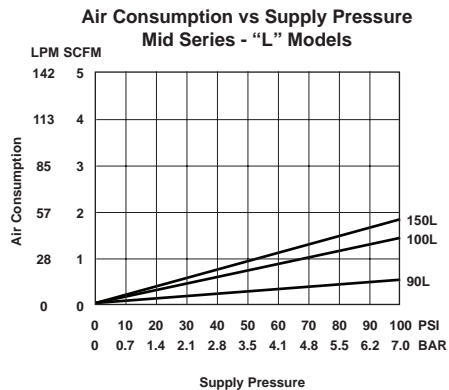

Notes: Standard operating pressure for Norgren generators is 80 PSI [5.5 bar]. Generators can be factory modified to run at other operating pressures i.e. 60 PSI [4.1 bar] etc. The values shown in the performance chart will remain the same for all operating pressures.



Performance Data - Max Series

Model	Air Consumption SCFM (L/min)	Vacuum Level "Hg (mbar)	0"Hg (0)	3"Hg (102)	6"Hg (203)	9"Hg (305)	10"Hg (339)	12"Hg (406)	15"Hg (508)	18"Hg (609)	20"Hg (677)	21"Hg (711)	24"Hg (813)	27"Hg (914)	28"Hg (948)
200L	2.80 (79.3)	Vacuum Flow SCFM (L/min)	6.00 (169.9)	5.80 (164.2)	4.30 (121.8)	1.70 (48.1)	0.00 (0.0)	- (-)	- (-)	- (-)	- (-)	- (-)	- (-)	- (-)	- (-)
		Evacuation time (seconds)	0.00 (0.0)	0.77 (0.0)	2.05 (0.1)	4.62 (0.2)	13.34 (0.5)	- (-)	- (-)	- (-)	- (-)	- (-)	- (-)	- (-)	- (-)
250L	4.80 (135.9)	Vacuum Flow SCFM (L/min)	9.50 (269.0)	7.90 (223.7)	5.70 (161.4)	2.20 (62.3)	0.00 (0.0)	- (-)	- (-)	- (-)	- (-)	- (-)	- (-)	- (-)	- (-)
		Evacuation time (seconds)	0.00 (0.0)	0.52 (0.0)	1.28 (0.0)	3.08 (0.1)	7.95 (0.3)	- (-)	- (-)	- (-)	- (-)	- (-)	- (-)	- (-)	- (-)
200M	4.80 (135.9)	Vacuum Flow SCFM (L/min)	6.00 (169.9)	5.30 (150.1)	4.90 (138.8)	4.00 (113.3)	- (-)	3.50 (99.1)	2.50 (70.8)	1.10 (31.1)	0 (0)	- (-)	- (-)	- (-)	- (-)
		Evacuation time (seconds)	0.00 (0.0)	0.75 (0.0)	1.90 (0.1)	3.20 (0.1)	- (-)	5.30 (0.2)	8.70 (0.3)	17.10 (0.6)	42.60 (1.50)	- (-)	- (-)	- (-)	- (-)
250M	7.80 (220.9)	Vacuum Flow SCFM (L/min)	9.50 (269.0)	9.20 (260.5)	8.30 (235.0)	7.00 (198.2)	- (-)	4.70 (133.1)	3.40 (96.3)	2.20 (62.3)	0 (0)	- (-)	- (-)	- (-)	- (-)
		Evacuation time (seconds)	0.00 (0.0)	0.45 (0.0)	1.10 (0.0)	2.40 (0.1)	- (-)	3.80 (0.1)	6.00 (0.2)	9.70 (0.3)	15.40 (0.50)	- (-)	- (-)	- (-)	- (-)
200H	7.80 (220.9)	Vacuum Flow SCFM (L/min)	5.40 (152.9)	4.70 (133.1)	3.85 (109.0)	3.30 (93.4)	- (-)	3.00 (85.0)	2.60 (73.6)	2.10 (59.5)	- (-)	1.60 (45.3)	1.20 (34.0)	0.60 (17.0)	0.00 (0.0)
		Evacuation time (seconds)	0.00 (0.0)	1.20 (0.0)	2.10 (0.1)	3.40 (0.1)	- (-)	5.20 (0.2)	7.70 (0.3)	11.50 (0.4)	- (-)	20.00 (0.7)	33.50 (1.2)	62.60 (2.2)	98.10 (3.5)
250H	12.50 (354.0)	Vacuum Flow SCFM (L/min)	9.00 (254.9)	8.50 (240.7)	7.85 (222.3)	7.00 (198.2)	- (-)	6.50 (184.1)	5.30 (150.1)	3.90 (110.4)	- (-)	2.50 (70.8)	1.80 (51.0)	0.90 (25.5)	0.00 (0.0)
		Evacuation time (seconds)	0.00 (0.0)	0.75 (0.0)	1.30 (0.0)	2.20 (0.1)	- (-)	3.50 (0.1)	5.60 (0.2)	9.10 (0.3)	- (-)	17.40 (0.6)	30.10 (1.1)	56.00 (2.0)	76.00 (2.7)

Evacuation time in seconds based on 1 cubic foot volume / "Hg (1 Liter Volume / mbar)

Performance Data - Max Series

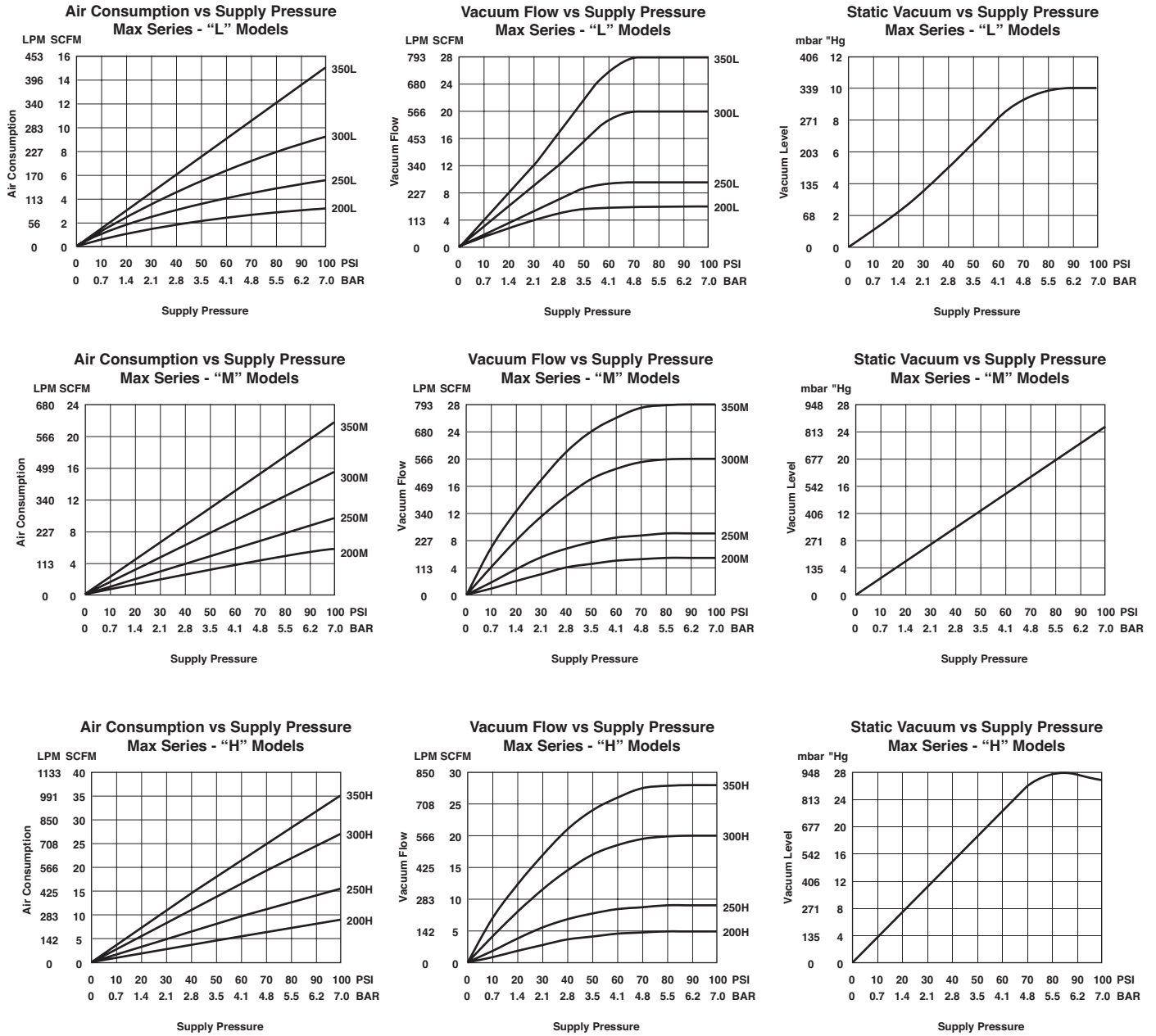

Notes: Standard operating pressure for Norgren generators is 80 PSI [5.5 bar]. Generators can be factory modified to run at other operating pressures i.e. 60 PSI [4.1 bar] etc. The values shown in the performance chart will remain the same for all operating pressures.



NAA Series Silencers

- » Compact
- » Lightweight
- » Durable
- » 3 Thread sizes 1/8, 1/4, 3/8
- » Closed-end silencer
- » Maximize performance – silences pneumatic equipment without back pressure.
- » Increase productivity and operator safety – reduces irritating noise, improves working environment
- » Closed-end silencer – contaminants can't escape
 - maintains clean environment
 - reduces maintenance costs
 - increases equipment life



NAA Series silencers have excellent noise reducing characteristics with minimal resistance to air flow. NAA Series silencers are one third smaller than comparable products, providing considerable space savings. The large surface of the felt element resists contamination far more than other materials such as sintered bronze, steel mesh or porous polyethylene.

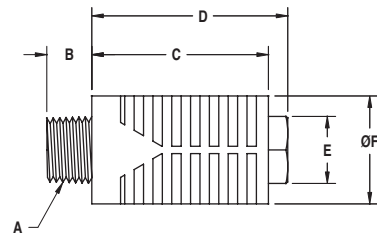

Part Number	Dimensions						Weight oz (g)	Construction				Noise Level
	A* in. (mm)	B in. (mm)	C in. (mm)	D in. (mm)	E in. (mm)	F in. (mm)		Body	Baffle	Screen	Element	
NAA2	1/8	0.23 (5.8)	0.97 (24.6)	1.08 (27.4)	0.39 (9.9)	0.61 (15.5)	0.1 oz (3g)					58dB
NAA4	1/4	0.32 (8.1)	1.26 (32.0)	1.39 (35.3)	0.47 (11.9)	0.77 (19.6)	0.2 oz (6g)	Nylon	Nylon	Nylon	Felt	62dB
NAA6	3/8	0.41 (10.4)	1.74 (44.2)	1.86 (47.2)	0.62 (15.8)	0.96 (24.4)	0.4 oz (11g)					70dB

*Fits NPT, BSPP and BSPT threads.

NAA Series Silencers Operating Specifications:

Max. Operating Pressure: Not to exceed 150 PSI (10 bar)

Noise level: Measured 4.5 ft on the diagonal from the silencer while attached to a Norgren generator. Noise levels will vary on Norgren and non-Norgren products.

Note 1: Norgren strongly recommends the use of silencers on all vacuum generators.

Note 2: Norgren silencers may be used on all types of pneumatic devices i.e. air-operated vacuum generators, air motors, valves, cylinders and more.

How to Specify:

- » **For Silencer only:** Order by Model #.
- » **Norgren generator/silencer combinations:** Norgren recommends silencers that have been sized to ensure maximum generator performance. See specific generator for silencer options.
- » **Non-Norgren pneumatic devices:** The thread size on the exhaust port of the pneumatic device determines the size of the silencer.
- » **Equipment and applications may vary.** Consult factory for proper silencer selection.

NST Series Silencers

- » Straight-through design
- » Felt liner provides low frequency sound
- » Male and female connections
- » 19 models
- » Reliable – straight through design – non-clogging
- » Maximize performance – silences pneumatic equipment without back pressure
- » Increase productivity and operator safety
- » Reduces irritating noise, improves working environment
- » Increase savings – reduces maintenance costs, increases equipment life



The NST Series Silencers are designed with a straight through flow path that eliminates clogging by allowing the contaminants to pass directly through the silencer. Each silencer is tuned in proportion to its exhaust flow to minimize noise.

As air passes through the silencer, the dense felt element absorbs the noise, thus reducing high pitch exhaust noise to a gentle, low frequency sound. Even in the most adverse conditions, contaminants pass through the silencer making the NST Series ideal for silencing vacuum generators that are continuously ingesting dirt and debris.

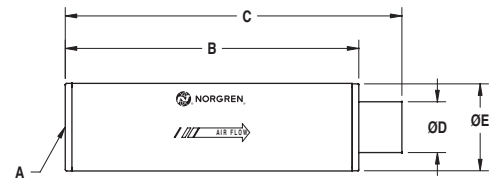

NST Series Silencers: Female Threads

Part Number	Dimensions					Weight oz (g)	Construction Body	Element	Noise Level
	A in. (mm)	B in. (mm)	C in. (mm)	D in. (mm)	E in. (mm)				
NST4AX	1/4 NPT F	3.19 (81.0)	3.56 (90.4)	0.50 (12.7)	1.00 (25.4)	1.8 oz (51g)	Anodized Aluminum	Felt	75dB
NST6AX2	3/8 NPT F	2.17 (55.1)	2.55 (64.7)	0.50 (12.7)	1.00 (25.4)	1.8 oz (51g)			75dB
NST6BX	3/8 NPT F	4.19 (106.4)	4.82 (122.4)	0.72 (18.3)	1.25 (38.1)	3.4 oz (96g)			77dB
NST8BX	1/2 NPT F	4.19 (106.4)	4.80 (121.9)	0.73 (18.5)	1.25 (31.8)	3.1 oz (88g)			76dB
NST16FC	1 NPT F	6.39 (162.3)	7.14 (181.4)	1.25 (31.8)	2.00 (50.8)	7.6 oz (215g)			80dB
NST24FC	1 1/2 NPT F	7.10 (180.3)	7.85 (199.4)	1.25 (31.8)	2.00 (50.8)	7.9 oz (224g)			82dB

NST Series Silencers Specifications:

Max. Operating Pressure: Not to exceed 150 PSI

Noise level: Measured 4.5 ft on the diagonal from the silencer while attached to a Norgren generator. Noise levels will vary on Norgren and non-Norgren products.

Note 1: Norgren strongly recommends the use of silencers on all vacuum generators.

Note 2: Norgren silencers may be used on all types of pneumatic devices i.e. air-operated vacuum generators, air motors, valves, cylinders and more.

Note 3: NST Silencers may be used on all Norgren vacuum generators.

Note 4: For Metric availability, consult factory.

How to Specify:

» **For Silencer only:** Order by Model #.

» **Norgren generator/silencer combinations:** Norgren recommends silencers that have been sized to ensure maximum generator performance. See specific generator for silencer options.

» **Non-Norgren pneumatic devices:** The thread size on the exhaust port of the pneumatic device determines the size of the silencer.

» Equipment and applications may vary. Consult factory for proper silencer selection.

NSTAA Series Silencers

- » Compact
- » Lightweight
- » Durable
- » Ultra quiet operation
- » 2 Thread sizes 1/4, 3/8 NPT
- » Maximize performance – silences pneumatic equipment without back pressure
- » Increase productivity and operator safety
- » Reduces irritating high pitch frequency noise
- » Improves working environment
- » Maintain clean environment – reduces maintenance costs, increases equipment life



A hybrid silencer that offers increased noise reduction by combining an NST silencer with an NAA silencer. The (closed-end) NAA silencer is attached to the end of a modified NST silencer, thus removing the flow through feature of the standard NST Series silencers.

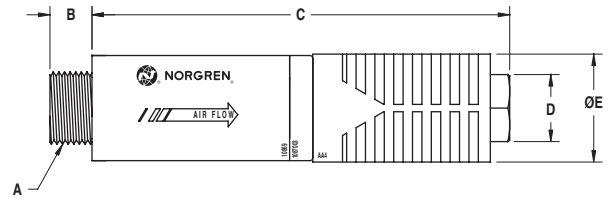

Model #	Dimensions					Weight oz (g)	Construction				Noise Level
	A in. (mm)	B in. (mm)	C in. (mm)	D in. (mm)	E in. (mm)		Body	Baffle	Screen	Element	
NSTAA4	1/4 NPS M	0.30 (7.6)	2.96 (75.2)	0.48 (12.2)	0.47 (11.9)	0.7 oz (20g)	Acetal/ Nylon	Felt/ Nylon	Nylon	Felt	58dB
NSTAA6	3/8 NPS M	0.38 (9.7)	5.15 (130.8)	0.63 (16.0)	0.62 (15.7)	1.8 oz (51g)	Aluminum/ Nylon	Felt/ Nylon	Nylon	Felt	64dB

NSTAA Series Silencers Specifications:

Max. Operating Pressure: Not to exceed 150 PSI [10 bar]

Noise level: Measured 4.5 ft on the diagonal from the silencer while attached to a Norgren generator. Noise levels will vary on Norgren and non-Norgren products.

Note 1: Norgren strongly recommends the use of silencers on all vacuum generators.

Note 2: Norgren silencers may be used on all types of pneumatic devices i.e. air-operated vacuum generators, air motors, valves, cylinders and more.

Note 3: For Metric availability, consult factory.

How to Specify:

- » **For Silencer only:** Order by Model #.
- » **Norgren generator/silencer combinations:** Norgren recommends silencers that have been sized to ensure maximum generator performance. See specific generator for silencer options.
- » **Non-Norgren pneumatic devices:** The thread size on the exhaust port of the pneumatic device determines the size of the silencer.
- » Equipment and applications may vary. Consult factory for proper silencer selection.



NFA-51 Series Silencers

- » Closed-end
- » 3 Thread sizes 1/4, 3/8, 1/2
- » Replacement elements available
- » Safe – closed-end high flows won't cause potentially dangerous projectiles
- » Quiets large vacuum generators, valves, cylinders, air motors, and more
- » Durable – more area inside to absorb sound and debris
- » Economical – lasts longer, lower cost, replacement elements available
- » Reliable – no back pressure on high flow applications
- » Maintain clean environment – reduces maintenance costs, increases equipment life



The NFA-51 Series silencers offer remarkable noise reduction for high volume exhaust applications without causing back pressure. These silencers are ideal for quieting large air valves that must exhaust quickly to maintain high cycle rates. Norgren uses the FNA-51 silencers on all high flow venturi vacuum generators where even a small amount of back pressure would decrease performance.

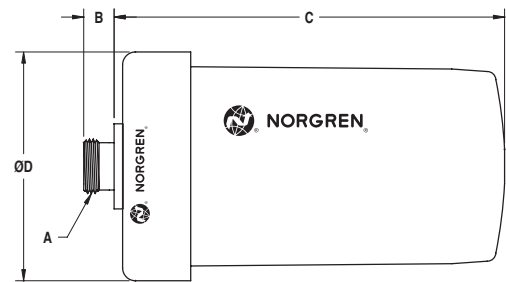

Part Number	Dimensions				Weight oz (g)	Construction				Noise Level
	A* in. (mm)	B in. (mm)	C in. (mm)	D in. (mm)		Body	Baffle	Screen	Element	
NFA-51-.250	1/4 NPS M	0.30 (7.6)								
NFA-51-.375	3/8 NPS M	0.38 (9.6)	5.74 (145.8)	3.36 (85.3)	12.7 oz (357g)					
NFA-51-.500	1/2 NPS M	0.38 (9.6)				Steel	Foam	Steel	Paper	72dB
NRF-51	N/A	N/A	4.76 (120.9)	3.03 (77.0)	6.2 oz (176g)					

NFA-51 Series Silencers Operating Specifications:

Max. Operating Pressure: Not to exceed 150 PSI [10 bar]

Noise level: Measured 4.5 ft on the diagonal from the silencer while attached to a Norgren generator. Noise levels will vary on Norgren and non-Norgren products.

Note 1: Norgren strongly recommends the use of silencers on all vacuum generators.

Note 2: Norgren silencers may be used on all types of pneumatic devices i.e. air-operated vacuum generators, air motors, valves, cylinders and more.

How to Specify:

- » **For Silencer only:** Order by Model #.
- » **Norgren generator/silencer combinations:** Norgren recommends silencers that have been sized to ensure maximum generator performance. See specific generator for silencer options.
- » **Non-Norgren pneumatic devices:** The thread size (1/4, 3/8, 1/2) on the exhaust port of the pneumatic device determines the size of the silencer i.e. NFA-51-.250
- » **P/N: NRF-51 - Replacement Element:** Fits all NFA-51 models
- » Equipment and applications may vary. Consult factory for proper silencer selection.

Electronic Vacuum Sensor

Ultra-miniature, precision control

- » Part present detection
- » End-of-Arm Tooling/
Robotic assembly
- » Material Handling
- » Monitoring vacuum vessels
- » Statistical process control
- » Compact – placed at point of use for accurate reading and quick response time
- » Lightweight – ideal for End-of-Arm Tooling, robotic end effectors
- » Low power consumption
- » Mountable to both Norgren or non-Norgren
- » M5 vacuum port
 - Swivel fitting – operates in any position
 - RoHS compliant and meets EMC standards
- » Standard with M8, 3-pin Quick Disconnect on 6" Pigtail



Norgren's ultra-mini electronic vacuum sensors provide continuous voltage output (1-5v) proportional to the system vacuum level. Connected to a feedback interface such as a digital display or PLC, the NVTMV-QD-6 is a cost effective, reliable sensor that maintains application consistency. Sensors can be mounted directly to Norgren's Modular NVP Series generators.

How to Specify:

Sensor: NVTMV-QD-6 - Sensor with 6" pigtail and Quick Disconnect

Accessory Options: NQDS-8-3F - Cordset with M8,3-pin female connector with 5M lead wire

NVTMV-QD-6 Sensor with Quick Disconnect:

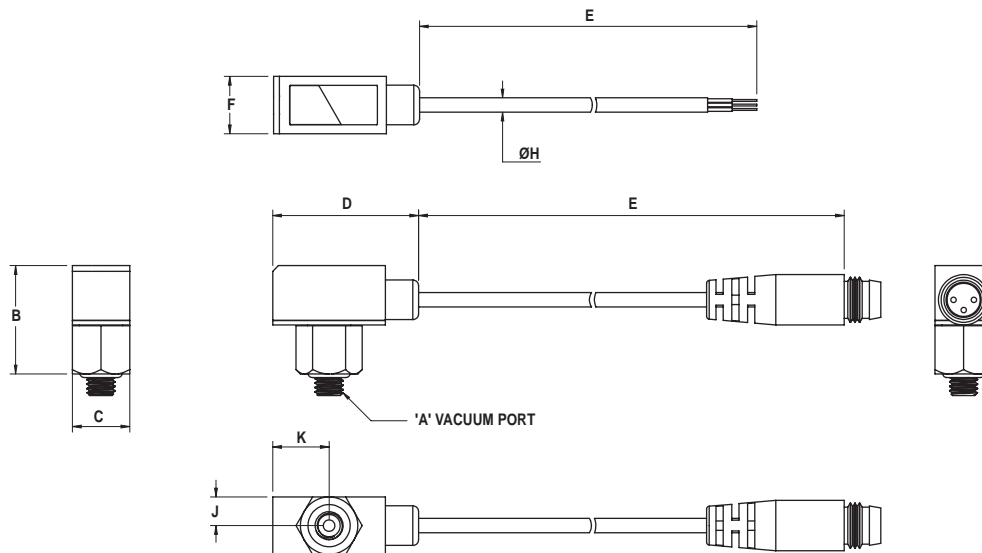

Part Number	Imperial Dimensions (in)										Weight oz
	A	B	C	D	E	F	H	J	K		
NVTMV-QD-6	10-32	0.75	.040	1.01	6.00	0.40	0.10	0.20	0.39	1.2oz	

Part Number	Metric Dimensions (mm)										Weight
	A	B	C	D	E	F	H	J	K		
NVTMVM-QD-6	M5	(19.1)	(10.1)	(25.7)	(152.4)	(10.1)	(2.5)	(5.1)	(9.9)	34.02g	



Wiring Schematic for NVTMV-QD-6

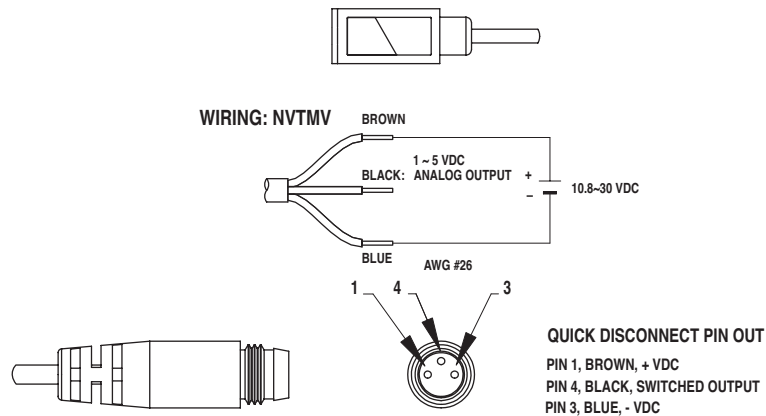

NVTMV-QD-6 Electronic Vacuum Sensor Specifications:

NVTMV-QD-6	
Rated Vacuum Range:	0" to 30" Hg [0 mbar to -1015 mbar]
Burst Pressure:	29 PSI (2 bar)
Media:	Non-Corrosive, Dry Gases
Supply Voltage:	10.8 to 30VDC
Current Consumption:	20 mA Max.
Sensing/Switching Material:	Single Crystal Silicon
Output:	1 to 5VDC
Electrical Connection:	3 Wire - 26 AWG - 6" (152.4 mm) with 3 pin, M8 Quick Disconnect
Response Time:	Approximately 1 ms
Circuit Protection:	None
Linearity:	+/- 0.5% Full Scale
Thermal Error:	+/- 2% Full Scale/121°F (50°C)
Thermal Compensation:	32°F to 121°F (0°C to 50°C)
Display:	None
IP Protection:	IP00
Operating Temperature:	15°F to 140°F (-10°C to 60°C)
Operating Humidity:	35 to 85% RH (No Condensation)
Construction:	Glass filed ABS/Aluminum/Buna
Fitting/Connection:	M5x.8 - 360° swivel male fitting
Weight:	1.2 oz (34.02g)
Safety and Environmental Compliance:	CE, RoHS

Electronic Vacuum Switches

Ultra-miniature, precision control

- » Part present detection
- » End-of-Arm Tooling/ Robotic assembly
- » Material handling
- » Pick & place
- » Manifold mount
- » Compact – placed at point of use for accurate reading and quick response time
- » Lightweight – ideal for End-of-Arm Tooling, robotic end effectors
- » Precision Control – offers field-adjustable set-point for the full vacuum range
- » Reliable LED for visual confirmation – easy set-up
- » Standard with M8, 3-pin Quick Disconnect on 6" Pigtail
- » Swivel fitting – operates in any position
- » Mountable to both Norgren or any non-Norgren M5 vacuum port
- Low power consumption
- RoHS compliant and meets EMC standards



Norgren's miniature electronic vacuum switches provide a switched output for part present detection and can be easily mounted to Norgren's Modular VP Series generators.

2 Models Available:

- NVSMN-QD-6** - NPN, 6" Pigtail
- NVSM-P-QD-6** - PNP, 6" Pigtail

Accessory Options:

- NQDS-8-3F** - Cordset with M8,3-pin female connector with 5M lead wire

NVSM(N or P) Series Switch with Quick Disconnect:

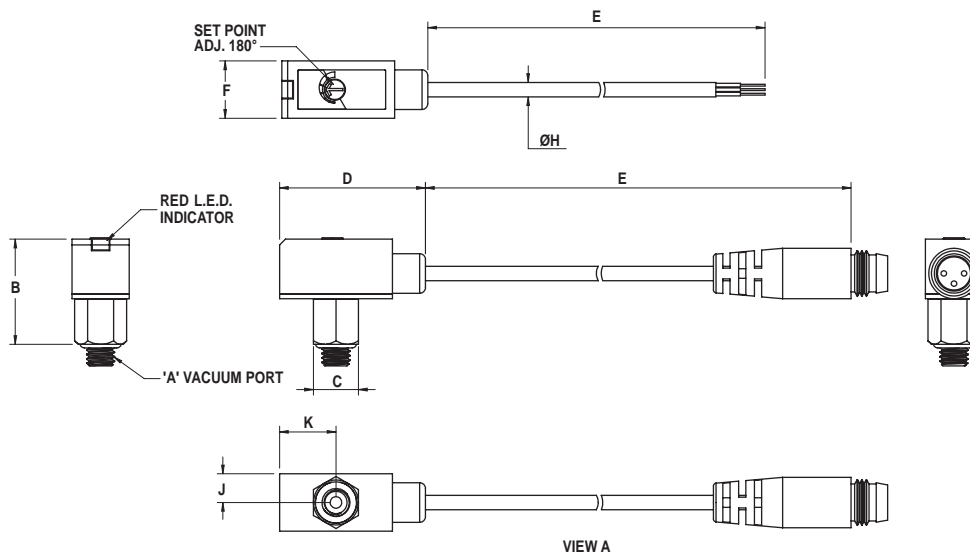

Part Number	Imperial Dimensions (in)									Weight
	A	B	C	D	E	F	H	J	K	
NVSM(N)(P)-QD-6	10-32	0.73	0.31	1.01	6.00	0.40	0.10	0.20	0.39	1.2 oz
Part Number	Metric Dimensions (mm)									Weight
	A	B	C	D	E	F	H	J	K	
NVSM(N)(P)M-QD-6	M5	(18.5)	(7.9)	(25.7)	(152.4)	(10.1)	(2.5)	(5.1)	(9.9)	34.02g



Wiring Schematic for NVSM (N or P)-QD-6

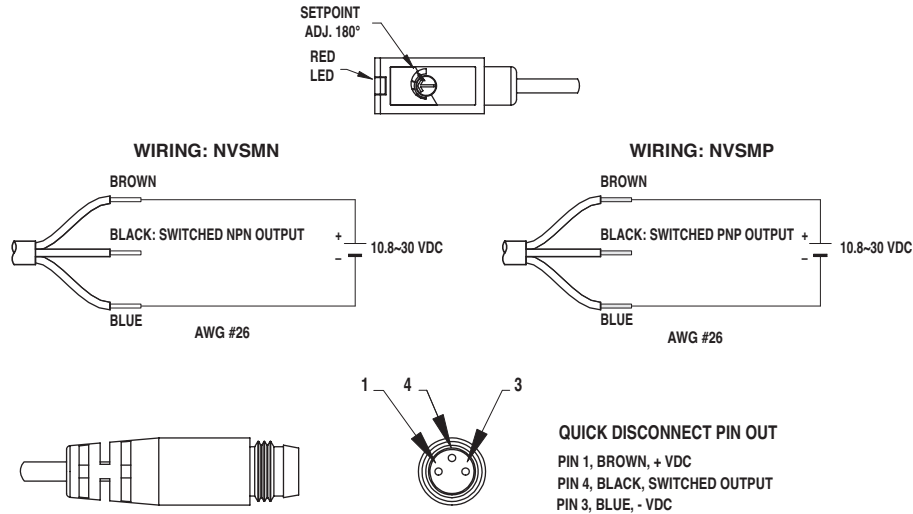

NVSM (N or P)-QD-6 Electronic Vacuum Switch Specifications:

NVSMN-QD-6 / NVSMP-QD-6	
Rated Vacuum Range:	0" to 30" Hg (-0 to -1015 mbar)
Burst Pressure:	29 PSI (2 bar)
Media:	Non-Corrosive, Dry Gases
Supply Voltage:	10.8 to 30VDC
Current Consumption:	20 mA Max.
Sensing/Switching Material:	Single Crystal Silicon
Switched Output:	NPN / PNP
Electrical Connection:	3 Wire - 26 AWG - 6" (152.4 mm) w/ 3 pin, M8 Quick Disconnect
Hysteresis:	2% Full Scale Max
Repeatability:	+/- 0.3% Full Scale
Response Time:	1 ms Max.
Circuit Protection:	NONE
Max. Switch Voltage Load:	30VDC
Max. Switched Current Load:	80mA
Linearity:	+/- 0.5% Full Scale
Thermal Error:	+/- 2% Full Scale/121°F (50°C)
Thermal Compensation:	32°F to 121°F (0°C to 50°C)
Display:	Single Red LED
Switch Indication:	Red LED ON (Switched Output ON)
IP Protection:	IP00
Operating Temperature:	15°F to 140°F (-10°C to 60°C)
Operating Humidity:	35 to 85% RH (No Condensation)
Construction:	Glass filled ABS/Aluminum/Buna
Fitting/Connection:	M5x.8 - 360° swivel male fitting
Weight:	1.2 oz (34.02g)
Safety and Environmental Compliance:	CE, RoHS

Electronic Vacuum Switch

Miniature, adjustable set-point and hysteresis,
M8, 3-pin Quick Disconnect

- » Part present detection
- » Pick & place
- » End of arm tooling
- » Material handling
- » Process control
- » Robotic assembly
- » Manifold mount
- » 1 switched output
- » Reliable LED visual confirmation – operator convenience
- » Field-adjustable set-point for the full vacuum range
- » Independent hysteresis adjustment – to meet application requirements
- » Vacuum port – Available with 1/8" NPT w/ 10-32 female, or G 1/8M w/ M5 female fitting
- » Standard with M8, 3-pin Quick Disconnect on 6" Pigtail
- » Compact – placed at point of use for accurate reading and quick response time
- » Lightweight - ideal for end of arm tooling, robotic end effectors and manifold systems
- » Mountable to both Norgren and non-Norgren vacuum generators
- » RoHS compliant



Norgren's miniature electronic vacuum switches monitor vacuum levels in systems and provide a switched output. The NVXX Series has both adjustable set-point and hysteresis and an LED indicator and can be mounted directly onto a wide variety of Norgren generators. Complete with M8, 3-pin connector.

2 Models Available:
NVXXN-QD-6 (NPN)
NVXXP-QD-6 (PNP)

Accessory Options:
NGDS-8-3F - Cordset with M8,3-pin female connector with 5M lead wire



NVXX(N, P)-QD-6 Series Switch with QD-6 Quick Disconnect

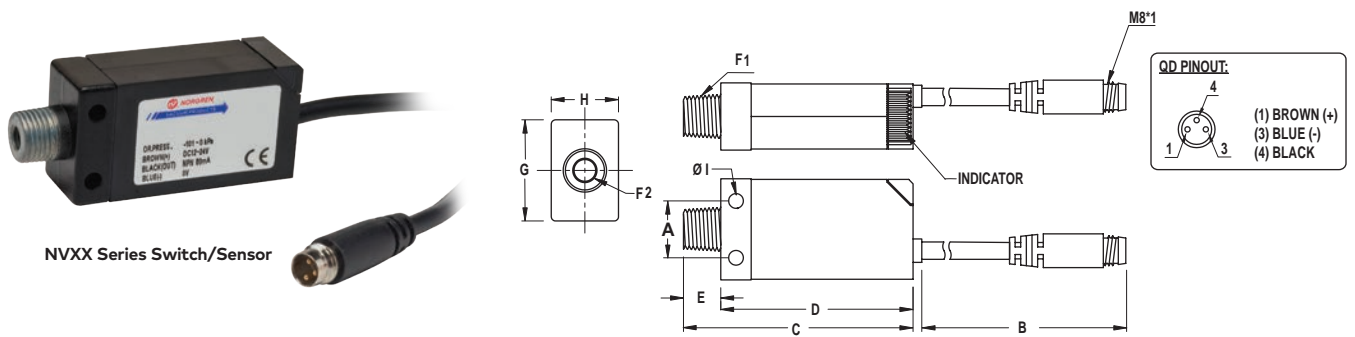

NVXX Series Switch/Sensor

Part Number	Dimension A		C	D	E	F1	F2	G	H	I	Weight (with male connection)
	in. (mm)	in. (mm)									
NVXX(N) (P)-QD-6	0.52	6.00	2.09	1.75	0.33	1/8 NPT	10-32	0.93	0.61	0.13	1.02 oz.
NVXX(N)(P)M-QD-6	(13.1)	(152.4)	(53.0)	(44.5)	(8.5)	G1/8	M5	(23.5)	(15.5)	(3.4)	31.75 g

Cordset with M8, 3-Pin Female Connector with 5M Lead Wire



Cordset

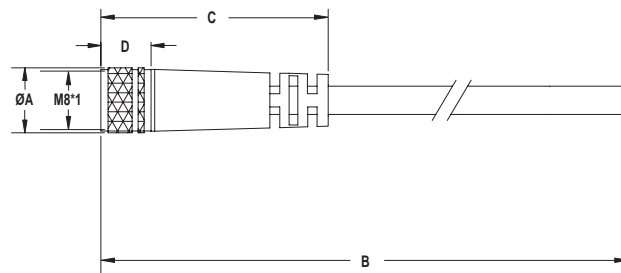

Part Number	Dimension A		B	C	D	Weight
	in. (mm)	ft. (M)				
NQDS-8-3F	0.35 (9.0)	16.40 (5M)	1.26 (32.0)	0.28 (7.0)	4.90 (140.0)	

Wiring Schematic for NVXX Series

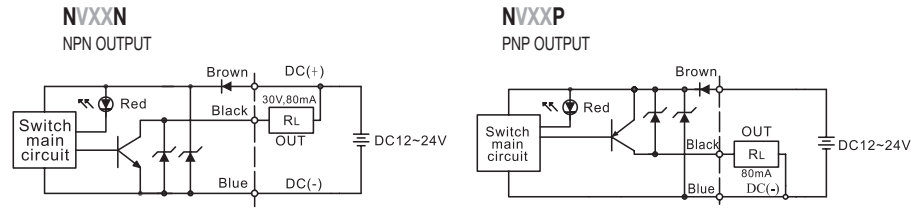

NVXX(N, P)-QD-6 Series Specifications:

NVXXN-QD-6 / NVXXP-QD-6		
Setting Pressure Range:	-101 – 0 kPa (-29.9" – 0"Hg)	
Withstand Pressure:	300 kPa (43.5 PSI)	
Fluid:	Air, Non-Corrosive /Non-flammable Gas	
Power Supply Voltage:	12 to 24VDC ± 10%, Ripple (P-P) 10% or less	
Output Method:	NPN Open Collection 30V 80mA / PNP Open Collection 80mA	
Hysteresis:	1-10% of Setting Presssure (Adjustable)	
Setting Point:	1 Point	
Operation Indicating Lamp:	Light at ON (Red)	
Current Consumption:	1 output: NPN & PNP: 21mA max.	
Repeatability (Switch Output):	±1% F.S.	
Response Time:	5ms or less	
Environment	Enclosure	IP 40
	Amb. temp range	Operation: 0-50°C, Storage: -20 – 60°C (no condensation or freezing)
	Amb. humidity range	Operation/Storage: 35 – 85% RH (no condensation)
	Withstand Voltage	1000VAC in 1-min (between case and lead wire)
	Insulation resistance	50Mohm min. (at 500VDC between case and lead wire)
	Vibration	Total amplitude 1.5mm, 10Hz-55Hz-10Hz scan for 1 minute, two hours each direction of X, Y, and Z
	Shock	980m/S ² (100G), 3 times each in direction of X, Y, and Z
Temperature Characteristic:	±3% F.S. (standard: 25°C)	
Port Size:	1/8" NPT, G 1/8, 10-32, M5	
Weight:	Approx. *1.2 oz (32g) (with male connector)	



Electronic Vacuum Switch with Digital Display

NVDX(N or P)-QD-6 Series – 2 Switched Outputs

- » Robotic control
- » Pick & place
- » Part present detection
- » Material handling
- » Monitoring vacuum
- » Leak testing
- » Fully Programmable – simple push button calibration – no tools required
- » 2 switched outputs
- » Convenient – standard with M8, 4-pin Quick Disconnect with 6" Pigtail
- » Vacuum port – Available with 1/8" NPT w/ 10-32 female or G 1/8M w/ M5 female fitting
- » Full 3 digit display – red LED
- » Globally accepted display scales: "Hg, mmHg, PSI, bar, mbar, gf/cm sq, kgf/cm sq, kPa
- » Dust and drip proof enclosure to IP65 IEC standards
- » RoHS compliant



NVDXN-QD-6

The NVDX Series compact all-in-one output device and digital gauge reduces the number of components in your system. With 2 switched outputs it's possible to monitor the high and low limits for vacuum control. In pick & place and robotic material handling applications, use the first switch for part present so that the robot or tooling can move, and the second switch to signal that the working vacuum level has been achieved. The NVDX Series can be directly mounted to a wide variety of Norgren generators. Complete with M8, 4-pin connector.

2 Models Available:
NVDXN-QD-6 (NPN)
NVDXP-QD-6 (PNP)

Accessory Options:
NGDS-8-4F - Cordset with M8, 4-pin female connector with 5M lead wire

NVDX(N, P)-QD-6 Series Switch/Sensor



NVDX Series Switch/Sensor

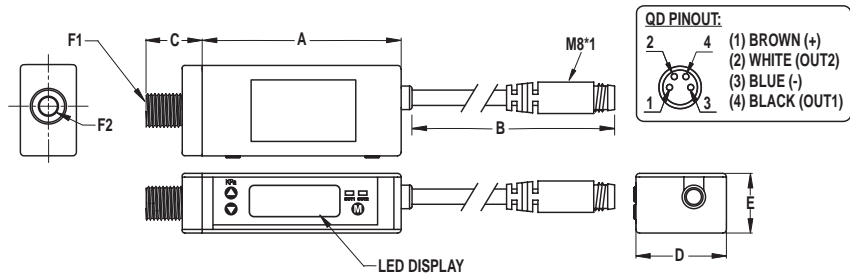

Part Number	Dimensions		F1	F2	Weight (with male connection) oz (g)
	A in. (mm)	B in. (mm)			
NVDX(N) (P)-QD-6	2.17	6.00	1/8 NPT	10-32	1.2 oz
NVDX(N)(P)M-QD-6	(55.0)	(152.4)	G 1/8	M5	(34.02g)

Cordset with M8, 4-Pin Female Connector with 5M Lead Wire



Cordset

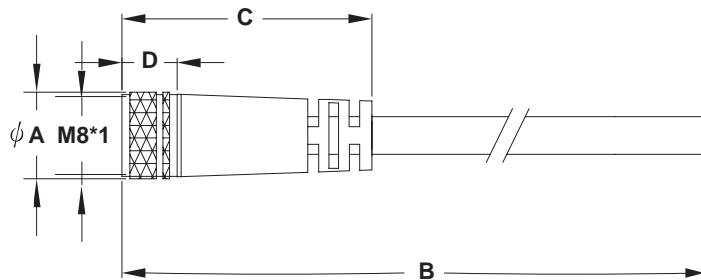

Part Number	Dimension				Weight oz (g)
	A in. (mm)	B ft. (M)	C in. (mm)	D in. (mm)	
NGDS-8-4F	0.35 (9.0)	16.40 (5M)	1.26 (32.0)	0.28 (7.0)	4.9 oz (140.0g)



Wiring Schematic for NVDX-Series

NVDXN
NPN OUTPUT

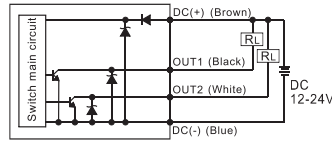

NVDXP
PNP OUTPUT

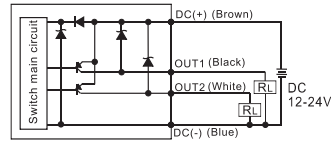

NVDX(N)(P)-QD-6 Series Specifications:

	NVDXN-QD-6	NVDXP-QD-6
Rated Pressure Range:	-101.3 - 0.0 kPa (-29.9 - 0"Hg)	
Setting Pressure Range:	-101.3 - 10.0 kPa (-29.9"Hg - 1.45 PSI)	
Withstand Pressure:	300 kPa (43.5 PSI)	
Fluid:	Air, Non-Corrosive Gases, Incombustible Gases	
Set Pressure Resolution	kPa	0.1
	MPa	-
	kgf/cm ²	0.001
	bar	0.001
	PSI	0.01
	InHg	0.1
	mmHg	1
	mmH ₂ O	0.1
Power Supply Voltage:	12 to 24VDC ± 10%, Ripple (P-P) 10% or less	
Current Consumption:	≤ 55mA	
Switch Output:	2 NPN open collector Max. load current: 80mA Max. supply voltage: 30VDC Residual voltage: ≤1V (load current 80mA)	2 PNP open collector Max. load current: 80mA Max. supply voltage: 24VDC Residual voltage: ≤1V (load current 80mA)
Repeatability (Switch Output):	≤±0.2% F.S. ±1 digit	
Hysteresis:	Adjustable	
Hysteresis Mode	Fixed (3 digits)	
Window Comparator Mode	Fixed (3 digits)	
Response Time:	≤2.5ms (chattering-proof function: 24ms, 192ms, and 768ms selections)	
Output Short Circuit Protection:	Yes	
7 Segment LCD Display:	3 digit LED 7 segment display (Sampling rate: 5 times/1 sec.)	
Indicator Accuracy:	≤±2% F.S. ±1 digit (ambient temperature: 25 ± 3°C)	
Switch On Indicator:	Green LED (OUT 1) Red LED (OUT 2)	
Environment	Enclosure	IP 40
	Amb. temp range	Operation: 0-50°C, Storage: -20 - 60°C (no condensation or freezing)
	Amb. humidity range	Operation/Storage: 35 - 85% RH (no condensation)
	Withstand Voltage	1000VAC in 1-min (between case and lead wire)
	Insulation resistance	50Mohm min. (at 500VDC between case and lead wire)
	Vibration	Total amplitude 1.5mm, 10Hz-55Hz-10Hz scan for 1 minute, two hours each direction of X, Y, and Z
Shock	980m/s ² (100g), 3 times each in direction of X, Y, and Z	
Temperature Characteristic:	≤±2% F.S. of detected pressure (25°C) at temp. Range of 0-50°C	
Port Size:	1/8" NPT, G 1/8, 10-32, M5	
Lead Wire:	Oil Resistance cable (0.15M)	
Weight:	Approx. *34g (with male connector)	

Electronic Vacuum Switch and Sensor with 3 Color, 3 Section Display

NVDM(N or P)-QD-6 Series – 2 Switched Outputs

Multi-color display that changes color when set-point is reached.

- » Robotic control
- » Pick & place
- » Part present detection
- » Material handling
- » Monitoring vacuum
- » Leak testing
- » 2 switched outputs
- » 3 color, 3 section display
- » Set-point displayed in sub-section – color changes when reached
- » Fully Programmable – simple push button calibration – no tools required
- » Vacuum port – Available with 1/8" NPT w/ 10-32 female or G 1/8M w/ M5 female fitting
- » Standard with M8, 4-pin Quick Disconnect on 6" Pigtail
- » Key lock indicator
- » Operating range includes both vacuum and pressure
- » Full 3 digit display – LED
- » Globally accepted display scales: "Hg, mmHg, PSI, bar, mbar, gf/cm sq, kgf/cm sq, kPa
- » Dust and drip proof enclosure to IP 40 IEC standards
- » RoHS compliant



NVDMP-QD-6

The NVDM Series compact all-in-one output device and digital gauge reduces the number of components in your system. Because the NVDM Series offers a choice of 2 switched outputs, NPN or PNP, it's possible to monitor the high and low limits for vacuum control and system conditions. In pick & place and robotic material handling applications use the first switch for part present so that the robot or tooling can move, and the second switch to signal that the working vacuum level has been achieved. The NVDM Series offers a multi-colored, multi-section display that provides a visual indication of system vacuum as well as the set-points. The set-point display changes color from red to green when set-point #1 is reached. If two set-points are used, each can be displayed by toggling back and forth using a single push button. The display also indicates when either set-point is reached and an output is activated. Complete with M8, 4-pin Quick Disconnect on 6" pigtail.

2 Models Available:

NVDMN-QD-6 (2 NPN)

NVDMP-QD-6 (2 PNP)

Accessory Options:

NMB-VDM & NPMC-VDM - Mounting Bracket Kits – Rear and bottom mount kit, Panel Mount Kit

NQDS-8-4F - Cordset with M8, 4-pin female connector with 5M lead wire



NVDM(N, P)-QD-6 Series Switch



NVDM Series Switch/Sensor

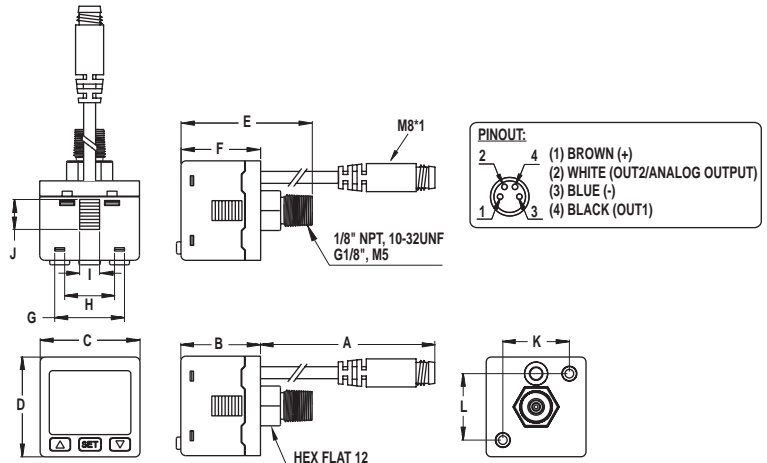

Part Number	Dimensions											Weight oz (g)	
	A in. (mm)	B in. (mm)	C in. (mm)	D in. (mm)	E in. (mm)	F in. (mm)	G in. (mm)	H in. (mm)	I in. (mm)	J in. (mm)	K in. (mm)		L in. (mm)
NVDM (N) (P)-QD-6	6.00	0.94	1.18	1.18	1.55	0.94	0.83	0.59	0.24	0.35	0.79	0.79	1.24 oz
NVDM(N)(P)M-QD-6	(152.4)	(23.9)	(30.0)	(30.0)	(39.4)	(12.9)	(21.0)	(15.0)	(6.0)	(9.0)	(20.0)	(20.0)	(38.6g)

Optional Mounting Brackets: Rear & Bottom Mount Brackets – NMB-VDM



NVDM Series Rear Mount Bracket

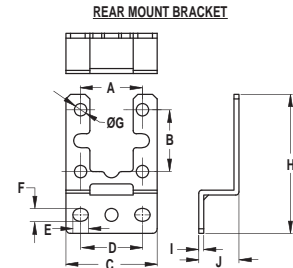
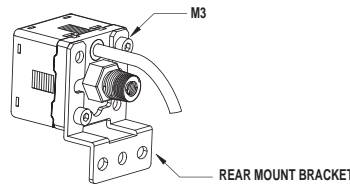

NVDM Series Bottom Mount Bracket

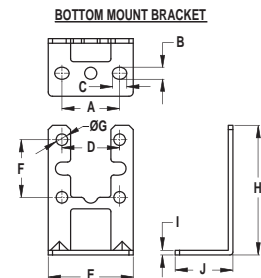
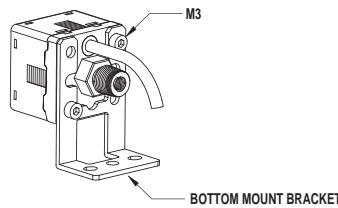

Part Number	Dimensions									
	A in. (mm)	B in. (mm)	C in. (mm)	D in. (mm)	E in. (mm)	F in. (mm)	G in. (mm)	H in. (mm)	I in. (mm)	J in. (mm)
NMB-VDM Rear Mount Bracket	0.79 (20.0)	0.79 (20.0)	1.16 (29.5)	0.79 (20.0)	0.20 (5.0)	0.16 (4.2)	0.16 (4.0)	1.77 (45.0)	0.06 (1.6)	0.51 (13.0)

Part Number	Dimension									
	A in. (mm)	B in. (mm)	C in. (mm)	D in. (mm)	E in. (mm)	F in. (mm)	G in. (mm)	H in. (mm)	I in. (mm)	J in. (mm)
NMB-VDM Bottom Mount Bracket	0.79 (20.0)	0.16 (4.2)	0.20 (5.0)	0.79 (20.0)	1.16 (29.5)	0.79 (20.0)	0.16 (4.0)	1.77 (45.0)	0.06 (1.6)	0.79 (20.0)

Optional Mounting Brackets: Panel Mount Bracket – NPMC-VDM

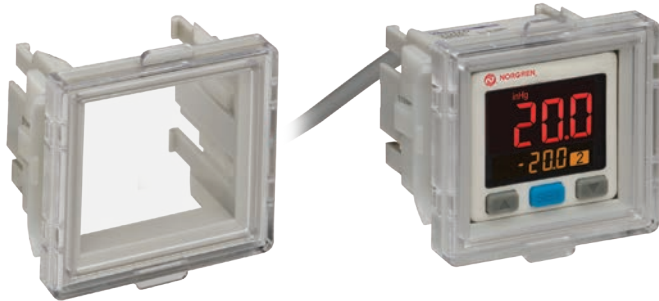

NVDM Series Panel Mount Bracket

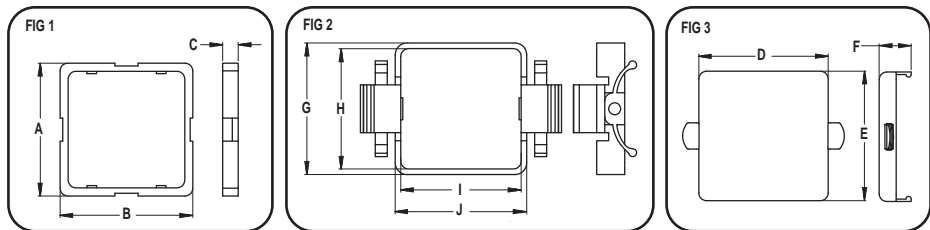
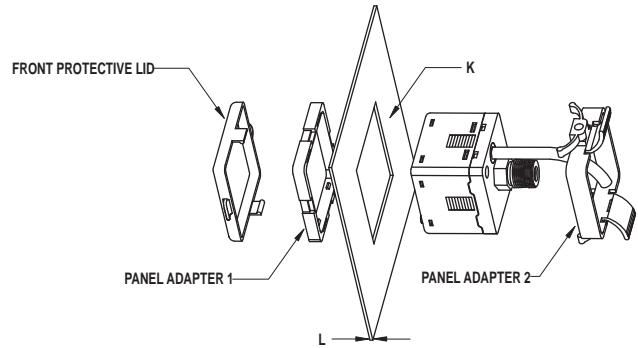

Part Number	Dimensions											
	A in. (mm)	B in. (mm)	C in. (mm)	D in. (mm)	E in. (mm)	F in. (mm)	G in. (mm)	H in. (mm)	I in. (mm)	J in. (mm)	K in. (mm)	L in. (mm)
NPMC-VDM Panel Mount w/Cover	1.35 (34.4)	1.35 (34.4)	0.16 (4.0)	1.35 (34.4)	1.35 (34.4)	0.33 (8.5)	1.30 (33.0)	1.19 (30.2)	1.19 (30.2)	1.30 (33.0)	1.22 X 1.2 ± 0.02 (31 X 31 ± 0.4)	t ≤ 0.18 (t ≤ 4.5)

Cordset with M8 Female Connector with 5M Lead Wire



Cordset

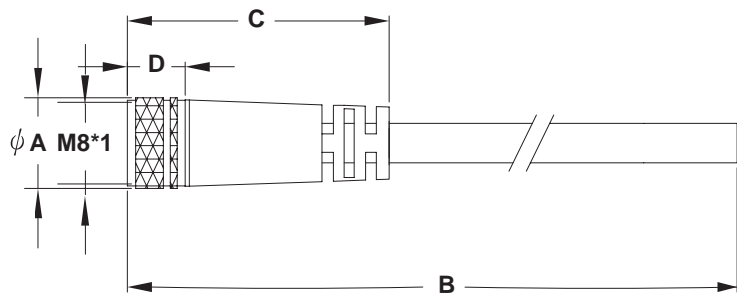

Part Number	Dimensions			
	A in. (mm)	B ft. (M)	C in. (mm)	D in. (mm)
NQDS-8-4F	0.35 (9.0)	16.40 (5.0)	1.26 (32.0)	0.28 (7.0)



Wiring Schematic for NVDM Series

NVDMN
NPN OUTPUT

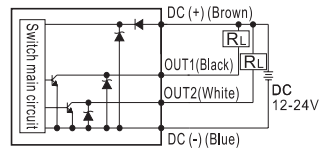

NVDM P
PNP OUTPUT

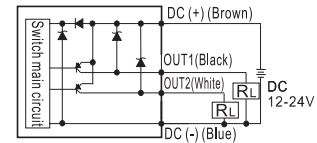

NVDM Series Specifications:

	NVDMN-QD-6	NVDM P-QD-6
Rated Pressure Range:	-101.3 ~ 0.0 kPa (-29.9 ~ 0" Hg)	
Setting Pressure Range:	-101.3 ~ 10.0 kPa (-29.9" Hg ~ 1.45 PSI)	
Withstand Pressure:	300 kPa (43.5 PSI)	
Fluid:	Air, Non-Corrosive Gases, Incombustible Gases	
Set Pressure Resolution	kPa	0.1
	MPa	-
	kgf/cm ²	0.001
	bar	0.001
	PSI	0.01
	InHg	0.1
	mmHg	1
Power Supply Voltage:	12 to 24VDC ± 10%, Ripple (P-P) 10% or less	
Current Consumption:	≤ 40mA (With no load)	
Switch Output:	2 NPN open collector Max. load current: 125mA Max. supply voltage: 30VDC Residual voltage: ≤ 1.5v (load current 125mA)	2 PNP open collector Max. load current: 125mA Max. supply voltage: 24VDC Residual voltage: ≤ 1.5v (load current 125mA)
Repeatability (Switch Output):	≤ ±.2% F.S. ±1 digit	
Hysteresis: Hysteresis Mode Window Comparator Mode	Adjustable	
Response Time:	≤ 2.5ms (chattering-proof function: 25ms, 100ms, 250ms, 500ms, 1000ms, and 1500ms selectable)	
Output Short Circuit Protection:	Yes	
7 Segment LCD Display:	Two Color (Red/Green) main & unit display, Orange sub-display (Sampling rate: 5 times/1sec.)	
Indicator Accuracy	≤ ±2% F.S. ±1 digit (ambient temperature: 25 ± 3°C)	
Switch On Indicator:	Orange 1 & 2 Indicator	
Environment	Enclosure	IP 40
	Amb. temp range	Operation: 0-50°C, Storage: -10 ~ 60°C (no condensation or freezing)
	Amb. humidity range	Operation/Storage: 35 ~ 85% RH (no condensation)
	Withstand Voltage	1000VAC in 1-min (between case and lead wire)
	Insulation resistance	50Mohm min. (at 500VDC between case and lead wire)
	Vibration	Total amplitude 1.5mm, 10Hz-55Hz-10Hz scan for 1 minute, two hours each direction of X, Y, and Z
Shock	100m/S ² (10g), 3 times each in direction of X, Y, and Z	
Temperature Characteristic:	≤ ±2% F.S. of detected pressure (25°C) at temp. Range of 0-50°C	
Port Size:	1/8" NPT, G 1/8, 10-32, M5	
Lead Wire:	Oil Resistance cable (0.15M)	
Weight:	Approx. *1.24 oz (39g) (with male connector)	

Electronic Vacuum Switch and Sensor Electronic Vacuum Switch and Sensor with Digital Display

NVDS(N or P)-QD-6 Series –
2 Switched Outputs and 1 Analog Output

- » Robotic control
- » Pick & place
- » Part present detection
- » Material handling
- » Monitoring vacuum
- » Leak testing
- » 2 switched outputs and 1 1-5 VDC Analog output
- » Full 3 digit display – red LED
- » Fully Programmable – simple push button calibration – no tools required
- » 2 ports – back and bottom for easy plumbing and design flexibility, 1/8" NPT or G 1/8M
- » Choice of switched output types – PNP or NPN
- » Globally accepted display scales: "Hg, mmHg, PSI, bar, mbar, gf/cm sq, kgf/cm sq, kPa
- » Dust and drip proof enclosure to IP65 IEC standards
- » Standard with M12, 5-pin Quick Disconnect with 6" Pigtail
- » RoHS compliant



NVDSN-QD-6

The NVDS Series compact all-in-one output device and digital gauge reduces the number of components in your system. With 2 switched outputs and one analog output it's possible to monitor the high and low limits for vacuum control and system conditions. In pick & place and robotic material handling applications, use the first switch for part present so that the robot or tooling can move, and the second switch to signal that the working vacuum level has been achieved. The analog output allows software control over the entire vacuum and pressure range with the ability to track system vacuum/pressure changes in real time. The switches are highly flexible due to selectable output functions such as switching point hysteresis and window comparator. Complete with M12, 5-pin connector.

2 Models Available:

NVDSN-QD-6 (2 NPN and 1 Analog)

NVDSP-QD-6 (2 PNP and 1 Analog)

Accessory Options:

NMB & NPMC - Mounting Bracket Kits – Rear and bottom mount kit,

Panel Mount Kit

NQDS-12-5F - Cordset with M12, 5-pin female connector with 5M lead wire



NVDS(N, P)-QD-6 Series Switch/Sensor



NVDS Series Switch/Sensor

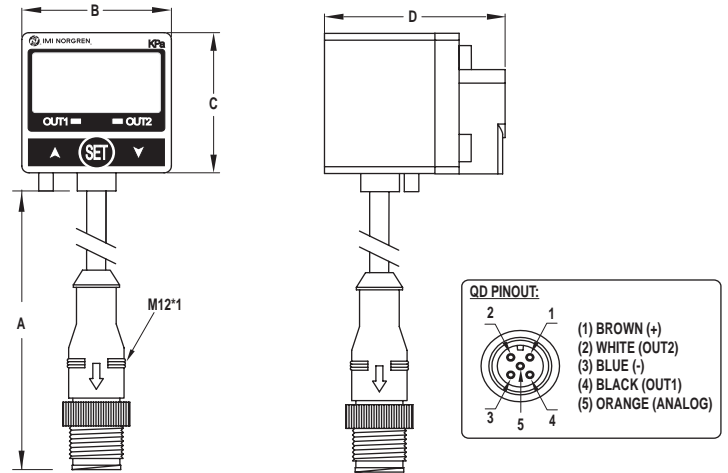

Part Number	Dimensions A in. (mm)	B in. (mm)	C in. (mm)	D in. (mm)	Weight oz (g)
NVDS (N) (P)-QD-6	6.00	1.22	1.22	1.44	2.48 oz
NVDS(N)(P)M-QD-6	(152.4)	(31.0)	(31.0)	(36.5)	(70.31g)

Optional Mounting Brackets: Rear & Bottom Mount Brackets – NMB



NVDS Series Rear Mount Bracket

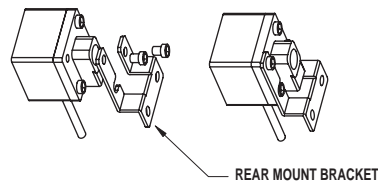

REAR MOUNT BRACKET

REAR MOUNT BRACKET

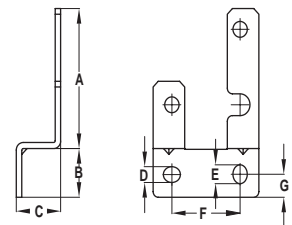

NVDS Series Bottom Mount Bracket

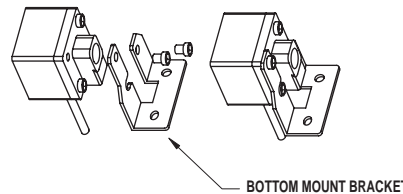

BOTTOM MOUNT BRACKET

BOTTOM MOUNT BRACKET

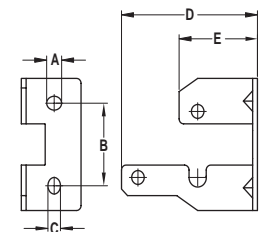

Part Number	Dimensions A in. (mm)	B in. (mm)	C in. (mm)	D in. (mm)	E in. (mm)	F in. (mm)	G in. (mm)
NMB Rear Mount Bracket	1.46 (37.1)	0.51 (12.9)	0.51 (13.0)	0.17 (4.2)	0.20 (5.1)	0.78 (20.0)	0.24 (6.1)

Part Number	Dimensions A in. (mm)	B in. (mm)	C in. (mm)	D in. (mm)	E in. (mm)
NMB Bottom Mount Bracket	0.20 (5.0)	0.98 (25.0)	0.17 (4.2)	1.79 (45.5)	1.03 (26.2)

Optional Mounting Brackets: Panel Mount Bracket – NPMC



NVDS Series Panel Mount Bracket

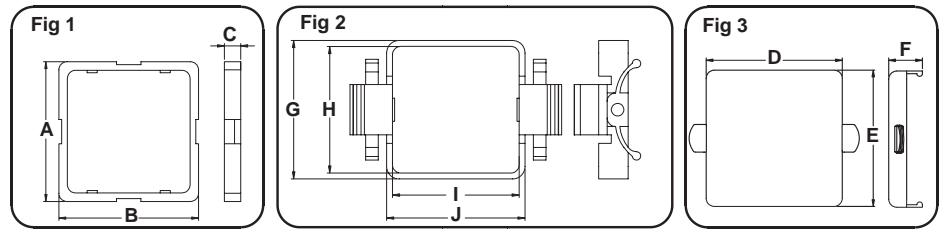

Part Number	Dimensions									
	A in. (mm)	B in. (mm)	C in. (mm)	D in. (mm)	E in. (mm)	F in. (mm)	G in. (mm)	H in. (mm)	I in. (mm)	J in. (mm)
NPMC Panel Mount w/Cover	1.58 (40.0)	1.58 (40.0)	0.18 (4.5)	1.40 (35.5)	1.67 (42.4)	1.67 (42.4)	0.28 (7.0)	1.87 (47.4)	1.42 X 1.42 ± 0.01 (36 X 36 ± .03)	t ≤ 0.18 (t ≤ 4.5)

Cordset with M12, 5-Pin Female Connector with 5M Lead Wire



Cordset/Connector/Lead Wire

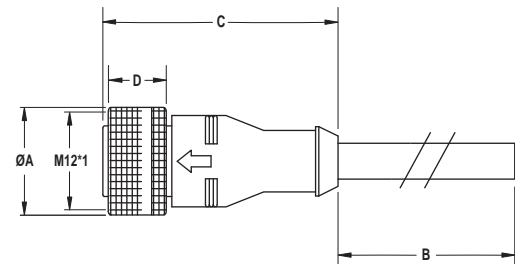
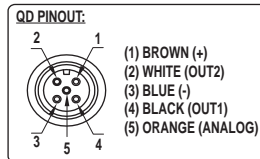

Part Number	Dimensions			
	A in. (mm)	B ft. (M)	C in. (mm)	D in. (mm)
NGDS-12-5F	0.35 (9.0)	16.4 ft (5M)	1.26 (32.0)	0.28 (7.0)



Wiring Schematic for NVDS-Series

NVDSN
NPN OUTPUT

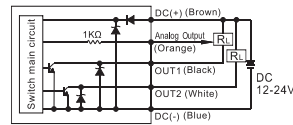

NVDSP
PNP OUTPUT

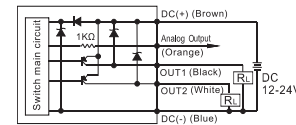

NVDS Series Specifications:

	NVDSN-QD-6	NVDSP-QD-6
Rated Pressure Range:	-101.3 - 0.0 kPa (-29.9 - 0"Hg)	
Setting Pressure Range:	-101.3 - 10.0 kPa (-29.9"Hg - 1.45 PSI)	
Withstand Pressure:	300 kPa (43.5 PSI)	
Fluid:	Air, Non-Corrosive Gases, Incombustible Gases	
Set Pressure Resolution	kPa	0.1
	MPa	-
	kgf/cm²	0.001
	bar	0.001
	PSI	0.01
	InHg	0.1
	mmHg	1
	mmH₂O	0.1
Power Supply Voltage:	12 to 24VDC ± 10%, Ripple (P-P) 10% or less	
Current Consumption:	55mA	
Switch Output:	2 NPN open collector Max. load current: 80mA Max. supply voltage: 30VDC Residual voltage: 1v (load current 80mA)	2 PNP open collector Max. load current: 80mA Max. supply voltage: 30VDC Residual voltage: 1.5v (load current 80mA)
Repeatability (Switch Output):	±0.2% F.S. ±1 digit	
Hysteresis:	Adjustable	
Hysteresis Mode	Fixed (3 digits)	
Window Comparator Mode	Fixed (3 digits)	
Response Time:	2.5ms (chattering-proof function: 25ms, 100ms, 250ms, 500ms, 1000ms, and 1500ms selectable)	
Output Short Circuit Protection:	Yes	
7 Segment LCD Display:	3 1/2 digit LED display (Sampling rate: 5 times/1 sec.)	
Indicator Accuracy:	±2% F.S. ±1 digit (ambient temperature: 25 ± 3°C)	
Switch On Indicator:	Green LED (OUT 1) Red LED (OUT 2)	
Analog Output (Voltage Output):	Output Voltage: 1 to 5v ± 2.5% F.S. (within pressure range) Linearity: ± 1% F.S.	
Environment	Enclosure	IP 65
	Amb. temp range	Operation: 0-50°C, Storage: -20 - 60°C (no condensation or freezing)
	Amb. humidity range	Operation/Storage: 35 - 85% RH (no condensation)
	Withstand Voltage	1000VAC in 1-min (between case and lead wire)
	Insulation resistance	50Mohm min. (at 500VDC between case and lead wire)
	Vibration	Total amplitude 1.5mm, 10Hz-55Hz-10Hz scan for 1 minute, two hours each direction of X, Y, and Z
Shock	980m/S ² (100G), 3 times each in direction of X, Y, and Z	
Temperature Characteristic:	±2% F.S. of detected pressure (25°C) at temp. Range of 0-50°C	
Port Size:	1/8" NPT, G1/8"	
Lead Wire:	Oil Resistance cable (0.15M)	
Weight:	Approx. *2.5 oz, (70g) (with male connector)	

Pneumatic Vacuum Switch

Converts a vacuum signal into a pneumatic signal
NVSP Series

- » Clamping and vacuum chucking
- » Pick & place of heavy loads
- » Hold vacuum while molds cool
- » Vessel evacuation
- » Lifting systems
- » Handling applications
- » Vacuum forming
- » Normally closed
- » Lightweight 2.6 oz (74g)
- » Intrinsically safe – no electricity required
- » Adjustable operating range from 0 to 25"Hg (0 to 847 mbar)
- » Rugged and durable – all aluminum construction
- » 3 Sensing ports for design flexibility – operates in any position
- » Economical – saves energy – minimizes compressed air consumption
- » Reliable and repeatable – diaphragm operated – long life
- » Easily installed and plumbed
- » Options:
Adjustment knob or slotted screw adjustment
2 Mounting options:
panel or flat mount



NVSP-NC

Norgren's Pneumatic Vacuum Switch provides a repeatable pneumatic output signal when reaching the user-defined vacuum set-point level and is appropriate for use in all vacuum systems.

The output signal is a voluminous 2.5 SCFM at 100 PSI, with a response time of 64 ms at 90 PSI. This high flow and fast response makes the switch ideal for high-speed pneumatic circuits with lengthy plumbing lines and for continuously monitored vacuum applications such as vacuum clamping (chucking), vacuum forming, vessel evacuation, and pick and place.

As an integral component of the Air Saver Generators, this switch supplies the pneumatic pilot signal that closes the main valve when the preset vacuum level is reached, minimizing compressed air consumption.

The pneumatic vacuum switch is constructed of an all-aluminum body ensuring sturdy installation and durable plumbing connections that last after repeated use.

Instant push-to-connect fittings connect the air supply quickly and easily, saving assembly time and eliminating the need for additional fittings. Three 10-32 vacuum ports allow for design and plumbing flexibility, while ensuring safe, neat, and space-saving fixtures.

The adjustment knob is smooth turning for fine adjustment. If you prefer a slotted adjustment mechanism, simply remove the knob to expose the slot.



Pneumatic Vacuum Switch

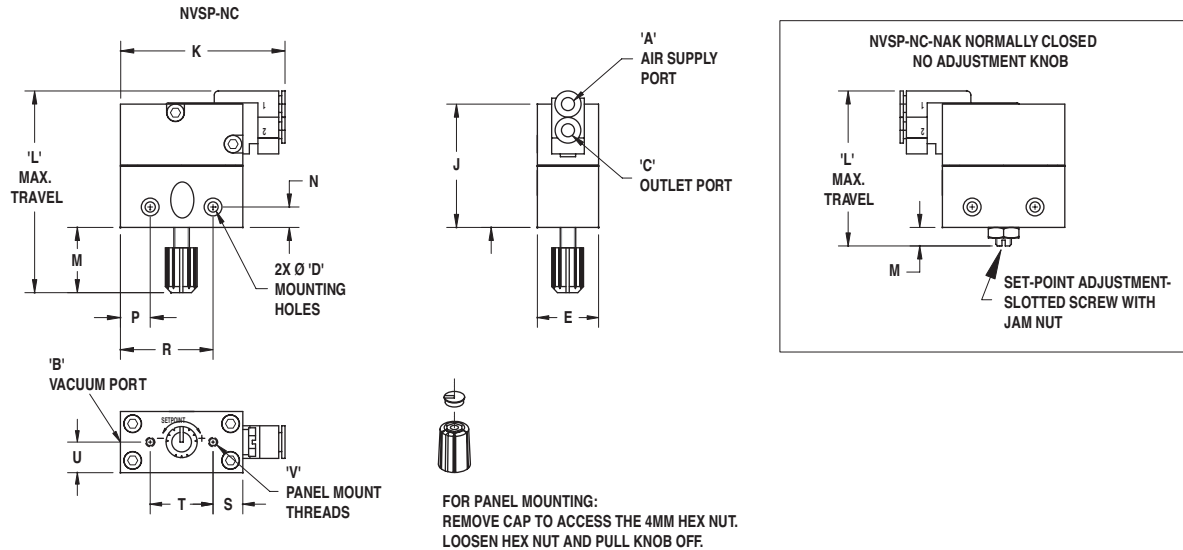

Part Number	Dimensions																Weight oz (g)
	A in. (mm)	B in. (mm)	C in. (mm)	D in. (mm)	E in. (mm)	J in. (mm)	K in. (mm)	L in. (mm)	M in. (mm)	N in. (mm)	P in. (mm)	R in. (mm)	S in. (mm)	T in. (mm)	U in. (mm)	V in. (mm)	
NVSP-NC	5/32- PTC	10-32	5/32- PTC	0.12 (3.0)	0.75 (19.1)	1.51 (38.4)	2.01 (51.0)	2.47 (62.7)	0.78 (19.8)	0.25 (6.4)	0.36 (9.1)	1.13 (28.7)	0.36 (9.1)	0.77 (19.6)	0.40 (9.5)	4-40 (N/A)	2.6 oz (74g)
NVSP-NC-NAK	5/32- PTC	10-32	5/32- PTC	0.12 (3.0)	0.75 (19.1)	1.51 (38.4)	2.01 (51.0)	1.68 (42.7)	0.22 (5.6)	0.25 (6.4)	0.36 (9.1)	1.13 (28.7)	0.36 (9.1)	0.77 (19.6)	0.40 (9.5)	4-40 (N/A)	2.6 oz (74g)

*PTC=Push-to-Connect-accepts 5/32 (4 mm) tubing

Switch Operation:

The pneumatic switch is a diaphragm-actuated air valve. At vacuum levels below the switch set point, the diaphragm depresses the valve plunger, closing the valve. When the vacuum level reaches the set point, the diaphragm releases the plunger, opening the valve, and allowing air to flow from port 1 to port 2. To change the set point, turn either the adjustment knob or slotted screw.

ANSI Symbol:

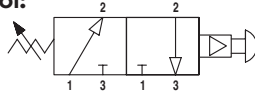

How to Specify:

Normally Closed: P/N: **NVSP-NC**

To order with slotted screw adjustment use P/N: **NVSP-NC-NAK**

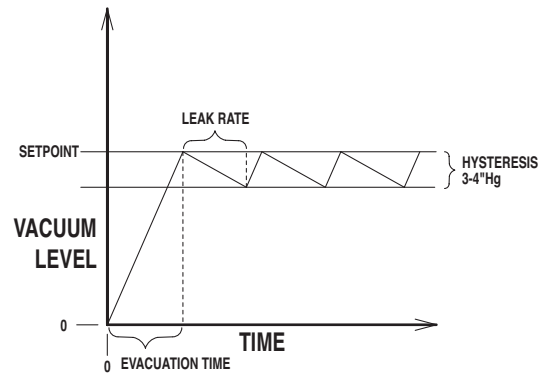

Pneumatic Vacuum Switch Specifications:

Rated Vacuum Range:	0" to 25" Hg (0 to 847 mbar)
Hysteresis:	3" to 4" Hg (102 mbar to -135 mbar)
Port Sizes:	Vacuum - 10-32 Female
Valve Type:	Plunger operated - air assisted servo controlled element
Operating Pressure:	20-115 PSI
Flow Rate:	2.5 SCFM @ 100 PSI
Cv Rating:	0.06
Response Time:	64 ms
Ambient Temp:	14°F to 140°F [-10C to 60C]
Mechanical Life:	10 million operations

Adjustable Mechanical Vacuum Switch

NVS-5 Series, NSX-5 Series, and NSX-5SB Series

- » Robotic applications
- » Assembly applications
- » Control applications
- » Monitoring applications
- » Accurate and reliable repeatability – utilizes low stress deflecting contacts
- » Compact and lightweight – operates in any position
- » Economical – diaphragm operated – long life
- » Easy to install – 12" flying leads, 24 AWG
- » Vacuum Level Range – VS-5, SX-5, SX-5SB - 0.4"-29.7"Hg (251mbar - 1 bar)

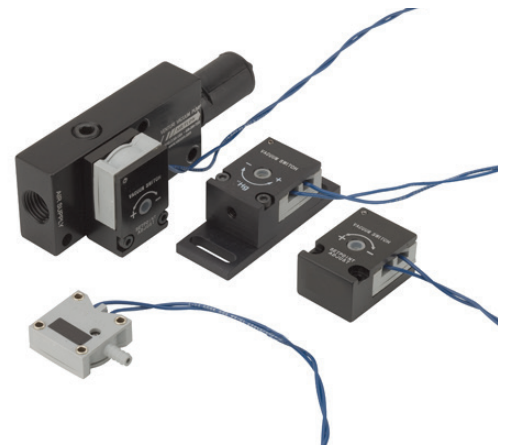

Vacuum Switches:

Norgren vacuum switches are ideal in automated systems to generate a low-current electrical signal for input to a PLC or other logic controllers. The adjustable switches are normally open, diaphragm operated, and contain low-stress deflecting contacts instead of sliding or pivoting parts for high reliability and long life.

Switch Options:

- Housings for ease of mounting on vacuum generators
- Sub base for ease of installation on non-Norgren vacuum generators

Adjustable Mechanical Vacuum Switch: NVS-5



NVS-5

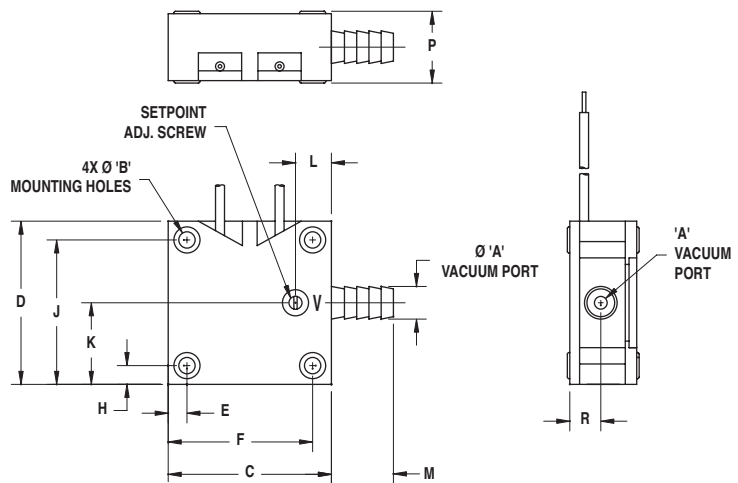

Part Number	Dimensions		C in. (mm)	D in. (mm)	E in. (mm)	K in. (mm)	H in. (mm)	J in. (mm)	K in. (mm)	L in. (mm)	M in. (mm)	N in. (mm)	P in. (mm)	R in. (mm)	S in. (mm)	Weight oz (g)	Lead Length
	A in. (mm)	B in. (mm)															
NVS-5	0.22 (5.6)	0.10 (2.5)	1.00 (25.4)	1.00 (25.4)	0.12 (3.0)	0.77 (19.6)	0.12 (3.0)	0.77 (19.6)	0.50 (12.7)	0.22 (5.6)	0.38 (9.7)	N/A (N/A)	0.44 (11.2)	0.20 (5.1)	0.50 (12.7)	0.5 oz (14g)	12 (305)



Adjustable Mechanical Vacuum Switch: NSX-5 (Switch with housing)



NSX-5 Switch with housing

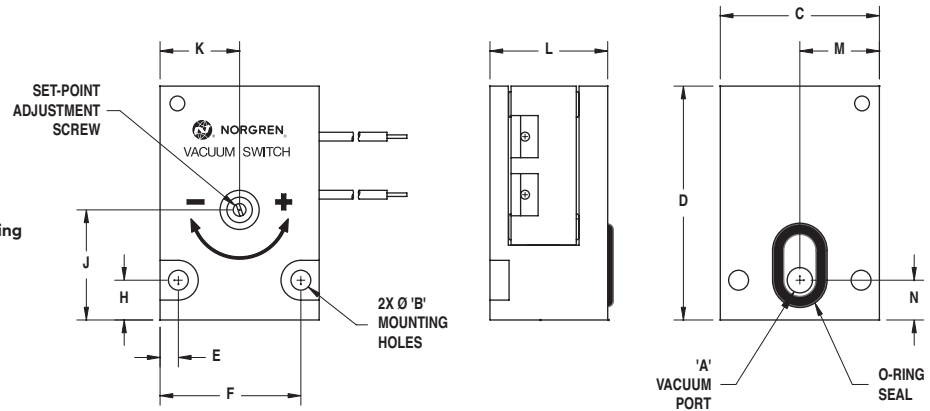

Part Number	Dimensions												Weight oz (g)	Lead Length
	A in. (mm)	B in. (mm)	C in. (mm)	D in. (mm)	E in. (mm)	F in. (mm)	H in. (mm)	J in. (mm)	K in. (mm)	L in. (mm)	M in. (mm)	N in. (mm)		
NSX-5	10-32 F (10-32 F)	0.13 (3.3)	1.00 (25.4)	1.47 (37.3)	0.12 (3.0)	0.89 (22.6)	0.25 (6.4)	0.69 (17.5)	0.50 (12.7)	0.74 (18.8)	0.50 (12.7)	0.25 (6.4)	1.5 oz (43g)	12 (305)

Adjustable Mechanical Vacuum Switch: NSX-5SB (Switch with housing and sub base)



NSX-5SB Switch with housing and sub base

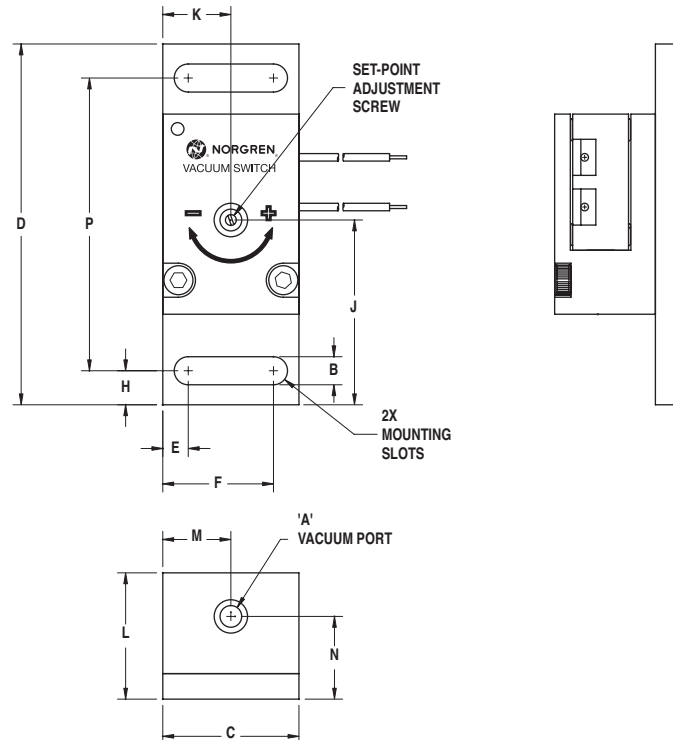

Part Number	Dimensions													Weight oz (g)	Lead Length
	A in. (mm)	B in. (mm)	C in. (mm)	D in. (mm)	E in. (mm)	F in. (mm)	H in. (mm)	J in. (mm)	K in. (mm)	L in. (mm)	M in. (mm)	N in. (mm)	P in. (mm)		
NSX5-SB	10-32 F 10-32 F	0.21 (5.3)	1.00 (25.4)	2.65 (67.3)	0.19 (4.8)	0.81 (20.6)	0.25 (6.4)	1.36 (34.5)	0.50 (12.7)	0.93 (23.6)	0.50 (12.7)	0.61 (15.5)	2.15 (54.6)	2.1 oz (60g)	12 (305)

Wiring Schematic for NVS-5, NSX-5, NSX-5SB

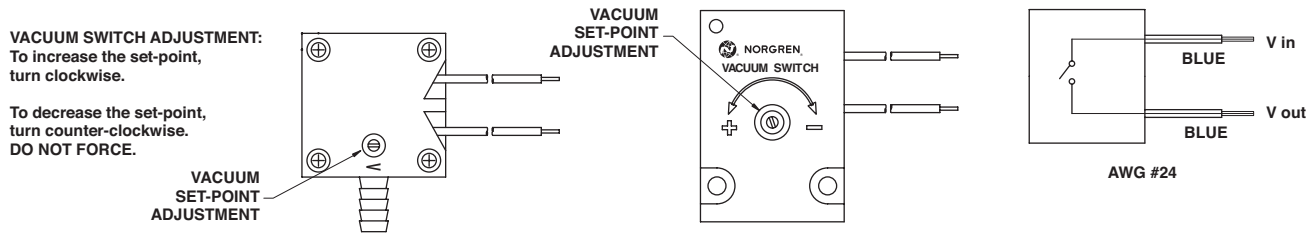

Important Notice For All NVS-5, NSX-5, NSX-5SB

1. The electrical current flows from one terminal through the rivet to the contact blade and from the other terminal through the rivet to the adjustment blade.
2. The adjustment screw is in contact with the diaphragm and is part of the electrical circuit.
3. To avoid potential shock, use an insulated screwdriver when making adjustments.

NVS-5, NSX-5, NSX-5SB Specifications:

	NVS-5	NSX-5, NSX-5SB
Rated Vacuum Range:	7.4" to 30" Hg (-250 to -1015 mbar)	7.4" to 30" Hg (-250 to -1015 mbar)
Proof Pressure:	N/A	
Burst Pressure:	25 PSI [1.7 bar]	
Media:	Non-Corrosive, Dry Gases	
Switch Type:	Differential Pressure, Mechanical Diaphragm	
Sensing/Switching Material:	Gold Plated, Phosphor Bronze	
Output:	SPST - NO	
Electrical Connection:	2 Wire - 24 AWG 1' [0.3M]	
Hysteresis:	0.5% Full Scale	
Max. Switch Voltage Load:	24VDC/500VAC	
Max. Switched Current Load:	20mA	
Display:	NONE	
Switch Indication:	NONE	
IP Protection:	NONE	
Operating Temperature:	-40°F to 250°F [-40°C to 120°C]	
Operating Humidity:	35 to 85% RH (No Condensation)	
Mechanical Life:	100,000,000 Cycles	
Construction:	GF Polyester/Polyurethane	GF Polyester/Polyurethane/Anodized Aluminum
Fitting/Connection:	3/16" barb	10-32 Female, Face Seal mount
Weight:	0.5 oz (14g)	NSX-5 - 1.5 oz (43g), NSX-5SB - 2 oz (57g)
Safety and Environmental Compliance:	RoHS	

How to Specify:

For switch only: Order by model number, i.e. **NSX-5**



Adjustable Mechanical Vacuum Switch

Compact, sealed vacuum switch for automation and process control applications
NVSW5A Series

- » Hazardous applications
- » Wash down applications
- » Dust-laden air environment
- » High amperage line voltage 120vAC
- » Vacuum range 5" to 30" Hg (-170 to 1015mbar)
- » Durable – Nema 6 Enclosure (IP65) protection for extremely dirty environments
- » Flexible – field adjustable between vacuum ranges
- » Easy to install – common electrical connection DIN 43650A
- » Safe – UL and CSA Approved
- » Versatile – can be wired for normally open or normally closed



NVSW5A – High amperage line voltage 120vAC

Vacuum Switches:

Norgren's NVSW5A is a high-current capacity switch capable of switching line voltage loads from 5 Amps to 125vAC. The sealed vacuum switch is field adjustable from 5 to 28" Hg (169 to 948 mbar). The vacuum level adjustment screw is easily accessed below the DIN connector. Wiring can be either normally open or normally closed.

Adjustable Mechanical Vacuum Switch: NVSW5A

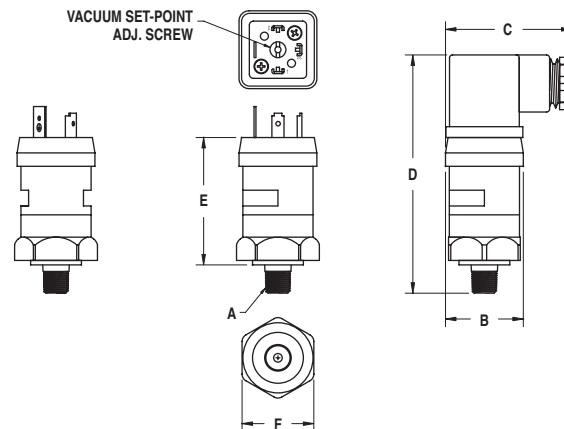

Part Number	Dimensions						Weight oz (g)
	A	B in. (mm)	C in. (mm)	D in. (mm)	E in. (mm)	F in. (mm)	
NVSW5A	1/8 NPT M 1/8 NPT M	1.22 (31.0)	1.98 (50.3)	3.74 (95.0)	2.00 (50.8)	1.13 (28.7)	4.1 oz (116g)

Wiring Schematic for NVSW5A: Set Point Adjustment

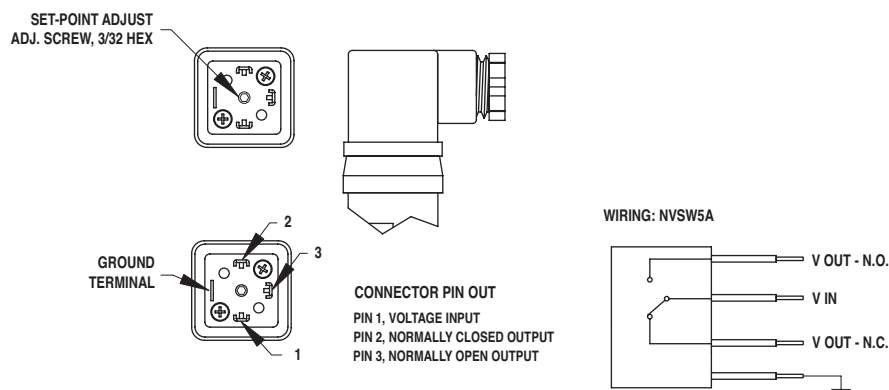

1. Remove center screw and DIN adaptor.
2. Place a 3/32" allen wrench into center hole.
3. Adjust counter-clockwise to increase set-point, clockwise to decrease set-point.
4. When desired setting is met, remove allen wrench and replace DIN adaptor and tighten screw.

NVSW5A Specifications:

Rated Vacuum Range:	5" to 30" Hg (-170 to -1015 mbar)
Proof Pressure:	45 PSI (3.1 bar)
Burst Pressure:	350 PSI (24 bar)
Media:	Non-Corrosive, Dry Gases
Switch Type:	Nitrile Diaphragm
Sensing/Switching Material:	N/A
Output:	SPDT
Electrical Connection:	DIN 43650A
Hysteresis:	3" to 4" Hg (-102 mbar to -135 mbar)
Repeatability:	+/- 2% Full Scale
Max. Switched Voltage Load:	12/24VDC, 125/250VAC
Max. Switched Current Load:	5A for 12/24VDC and 125VAC, 3A - for 250VAC
Display:	NONE
Switch Indication:	NONE
IP Protection:	IP65
Operating Temperature:	-20°F to 180°F (-28°C to 82°C)
Operating Humidity:	35 to 85% RH (No Condensation)
Mechanical Life:	100,000,000 Cycles
Construction:	Brass Housing, Nitrate Diaphragm
Fitting/Connection:	1/8" NPT Male
Weight:	4.0 oz. (113g)
Safety and Environmental Compliance:	UL, CSA, VDE and UR

How to Specify:

Order by part number: **NVSW5A**



Cordsets

For Electronic Vacuum Switches & Sensors

NQDS Series

- » Robotic devices
- » Automated assembly devices
- » Heavy-duty industrial environments
- » IP 67
- » Factory installed or field-attachable
- » Threaded couplings for harsh environments
- » Quick replacement & easy field conversion
- » Easy disconnect for system maintenance
- » RoHS compliant



Female cordset

Depending on your wiring needs, Norgren offers 5 meter female cordsets for complete wiring systems for quick, easy and safe connection to system controllers, PLC's, and other electronic extension connectors.

Quick Disconnect Options:

3-Pin, 4-Pin, or 5-Pin Cordsets
M8 and M12 Threads

Molded Single End Cordsets				
Model #	Pin Connection	Thread Size	IP Rating	Norgren Sensor/Switch
NQDS-8-3F	3-Pin Female	M8	IP 67	NVTMV-QD-6, NVSMN-QD-6, NVSMP-QD-6, NVXXN-QD-6, NVXXP-QD-6
NQDS-8-4F	4-Pin Female	M8	IP 67	NVDXN-QD-6, NVDXP-QD-6, NVDMN-QD-6, NVDMN-QD-6,
NQDS-12-5F	5-Pin Female	M12	IP 67	NVDSN-QD-6, NVDSP-QD-6

Note: Standard cordset length is 5 meters. Other lengths available. Consult factory.

M8 Single-Ended Cordset – 3-Pin Female



NQDS-8-3F

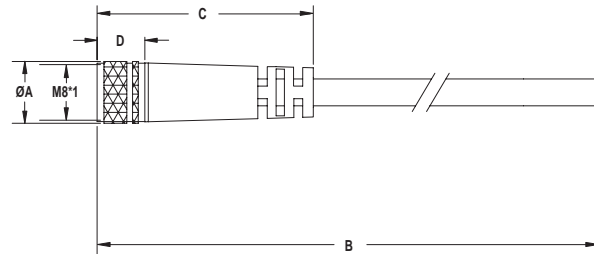
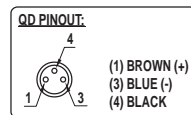

Part Number	Dimensions		C in. (mm)	D in. (mm)	Weight oz (g)
	A in. (mm)	B ft. (M)			
NQDS-8-3F	0.35 (9.0)	16.40 (5M)	1.26 (32.0)	0.28 (7.0)	4.9 oz (140g)

Specifications:

Cable:	Grey, PVC cable jacket
Conductors:	3x #24 AWG [3 x 0.22 mm]
Outside Diameter:	0.177" [4.5mm]
Electrical:	60 VAC/VDC
Amperage:	3A
Environmental:	IP 67
Ambient Operating Temp:	-48° to 176°F [-20° to 80°C]
Cord Length:	5 meters – Consult factory for other lengths

M8 Single-Ended Cordset – 4-Pin Female



NQDS-8-4F

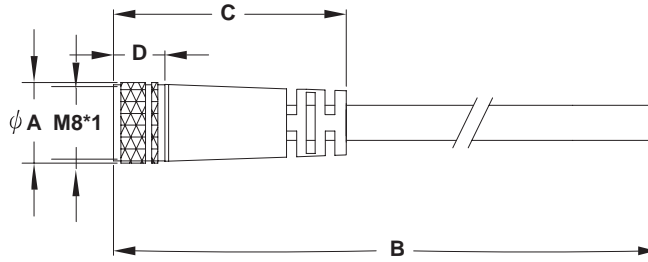

Part Number	Dimensions A in. (mm)	B ft. (M)	C in. (mm)	D in. (mm)	Weight oz (g)
NQDS-8-4F	0.35 (9.0)	16.40 (5M)	1.26 (32.0)	0.28 (7.0)	4.9 oz (140g)

Specifications:

Cable:	Grey, PVC cable jacket
Conductors:	4x #24 AWG (4 x 0.22 mm)
Outside Diameter:	0.177" (4.50 mm)
Electrical:	60 VAC/VDC
Amperage:	3A
Environmental:	IP 67
Ambient Operating Temp:	-48° to 176°F (-20° to 80°C)
Cord Length:	5 meters – Consult factory for other lengths

M12 Single-Ended Cordset – 5-Pin Female



NQDS-12-5F

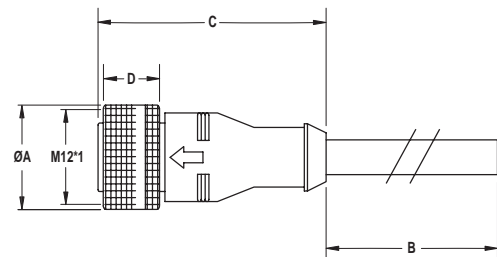
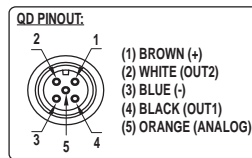

Part Number	Dimensions A in. (mm)	B ft. (M)	C in. (mm)	D in. (mm)	Weight oz (g)
NQDS-12-5F	0.35 (9.0)	16.40 (5M)	1.26 (32.0)	0.28 (7.0)	4.2 oz (119g)

Specifications:

Cable:	Grey, PVC cable jacket
Conductors:	5 x #25 AWG (5 x 0.34 mm)
Outside Diameter:	0.197" (5 mm)
Electrical:	60 VAC/VDC
Amperage:	4A
Environmental:	IP 67
Ambient Operating Temp:	-48° to 167°F (-20° to 80°C)
Cord Length:	5 meters – Consult factory for other lengths



NVCV Series

- » Clamping and vacuum chucking
- » Pick & place of heavy loads
- » Hold vacuum while molds cool
- » Vessel evacuation
- » Material handling applications
- » Productive – high flow capacity for rapid evacuation
- » Safe – minimum flow restriction ensures holding force
- » Energy efficient – extremely low cracking pressure <1"Hg (34mbar) reaches vacuum level quickly
- » Compact & lightweight – easily mounts to Norgren or non-Norgren vacuum products
- » Options:
 - Optional sensor/switch for positive pressure release
 - 3 Body sizes
 - 4 Thread sizes – 1/8" to 1/2" NPT

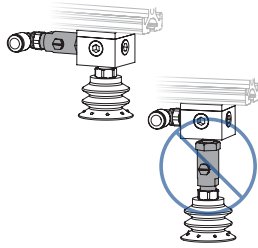

Vacuum check valves are not designed to directly support load bearing forces of any kind.

Norgren vacuum check valves seal and hold vacuum for safe, energy efficient operations for clamping, pick & place and vessel evacuation applications. Norgren vacuum check valves are designed specifically for vacuum applications. They offer high flow capacity with minimal flow restriction and feature extremely low cracking pressures of less than 0.5"Hg (16.93mbar). The large unrestricted flow path ensures high flow at low vacuum levels. The low cracking pressure allows the vacuum system to reach its maximum vacuum level before the check valve seals off the system.

With their high flow capacity and low cracking pressure, Norgren vacuum check valves offer rapid evacuation which increases process or production speed and reduces cycle times for more efficient operations.

In contrast, most spring-loaded check valves marketed today are designed for high pressure systems and have high cracking pressures. When used in vacuum applications, spring-loaded check valves severely restrict vacuum flow, hindering the performance of the vacuum generator by slowing down evacuation speed and wasting energy.

Norgren vacuum check valves are made of durable anodized aluminum with an internal flexible valve sealing mechanism. Norgren Vacuum Check Valves may be used with non-Norgren vacuum products.

Part Number	Cracking Pressure	Maximum Vacuum Flow w/ Zero Flow Restriction	Body Material	Valve Material	Operating Temperature	Proper Check Valve/Generator Combination (matched by flow and port size)
NVCV-75-18	4.30" H ₂ O (10.7 mbar)	4.0 SCFM (113 lpm)	Anodized Aluminum	EPDM	-20°F to +220°F (-29°C to +105°C)	NHVP-100 NJ Series generators 60 through 150 NVP Series generators 60 through 150
NVCV-75-14	4.30" H ₂ O (10.7 mbar)	4.0 SCFM (113 lpm)	Anodized Aluminum	EPDM	-20°F to +220°F (-29°C to +105°C)	NHVP-200 VDF 100 and 150 NVP Series generators 60 through 150
NVCV-100-14	1.60" H ₂ O (4.0 mbar)	20.00 SCFM (566 lpm)	Anodized Aluminum	Silicone	-50°F to +392°F (-46°C to +200°C)	NHVP-300 NVDF 20 and 25
NVCV-100-38						NJ Series - 200 and 250
NVCV-100-12						NVP80 Series - 200 and 250 For use with non-Norgren products
NVCV-125-38	2.70" H ₂ O (6.7 mbar)	30.0 SCFM (849 lpm)	Anodized Aluminum	EPDM	-20°F to +220°F (-29°C to +105°C)	NJ Series - 200 and 250 NVP80 Series - 200 and 250
NVCV-125-12						NVDF-37 NJ Series 300 and 350 NVP Series 300 and 350

CHECK VALVES



NVCV Series



NVCV-75 Series



NVCV-100 Series



NVCV-125 Series

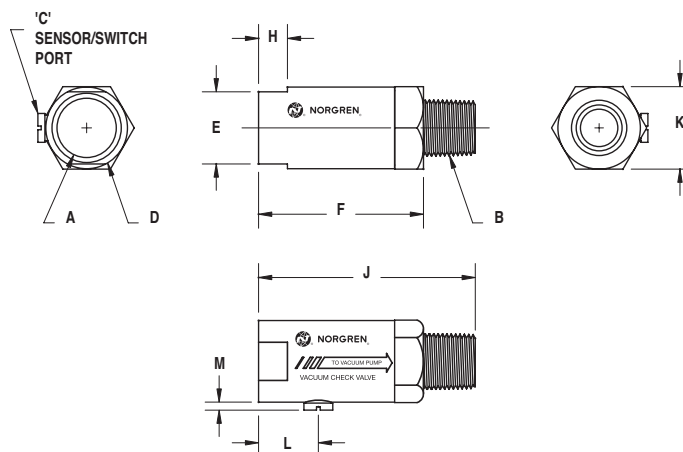

Part Number	Imperial Dimensions (in.)											Weight oz
	A	B	C	D	E	F	H	J	K	L	M	
NVCV-75-18	1/4 NPT F	1/8 NPT M	10-32	0.74	0.63	1.50	0.25	1.90	0.75	0.59	0.25	0.7 oz
NVCV-75-14	1/4 NPT F	1/4 NPT M						1.90				0.8 oz
NVCV-100-14	1/2 NPT F	1/4 NPT M	10-32	0.99	0.88	2.00	0.35	2.50	1.00	0.73	0.25	1.5 oz
NVCV-100-38	1/2 NPT F	3/8 NPT M						2.44				1.4 oz
NVCV-100-12	1/2 NPT F	1/2 NPT M						2.60				1.5 oz
NVCV-125-38	3/4 NPT F	3/8 NPT M	10-32	1.24	1.13	2.00	0.35	2.60	1.25	0.73	0.25	2.5 oz
NVCV-125-12	3/4 NPT F	1/2 NPT M						2.60				2.1 oz

Part Number	Metric Dimensions (mm)											Weight g
	A	B	C	D	E	F	H	J	K	L	M	
NVCVM-75-18	G 1/4	G 1/8	10-32	(18.8)	(15.9)	(38.1)	(6.4)	(48.3)	(19.1)	(14.9)	(6.4)	(20g)
NVCVM-75-14	G 1/4	G 1/4						(48.3)				(23g)
NVCVM-100-14	G 1/2	G 1/4	10-32	(25.1)	(22.2)	(50.8)	(8.9)	(63.5)	(25.4)	(18.4)	(6.4)	(43g)
NVCVM-100-38	G 1/2	G 3/8						(62.0)				(40g)
NVCVM-100-12	G 1/2	G 1/2						(66.0)				(43g)
NVCVM-125-38	G 3/4	G 3/8	10-32	(31.5)	(28.6)	(50.8)	(8.9)	(66.0)	(31.8)	(18.4)	(6.4)	(71g)
NVCVM-125-12	G 3/4	G 1/2						(66.0)				(60g)

How to Specify:

Order check valve by part number i.e. **NVCV-125-12**.

For metric availability, please consult factory.

VACUUM GAUGES

Center, Bottom and Panel Mount Styles



- » Accurate monitoring – easy visual confirmation for operator, ensures consistent performance
- » Effective diagnostic tool – debug and troubleshoot systems
- » Economical – low cost, long life
- » Dry or glycerin filled
- » 3 mounting positions: bottom mount, center back mount or panel mount
- » 2 dial sizes
- » Materials available: Black ABS or Steel



Norgren vacuum gauges are used in almost every area of automation including applications in pneumatics, process control, packaging, printing, medical, food and pharmaceutical.

Glycerin filled gauges extend gauge life and increase readability by dampening pulsing and vibration. All glycerin filled gauges feature a stainless steel case and bezel.

All gauges are protected with a limiting orifice to limit pressure shock. Standard dial faces have a dual scale in "Hg and bar.

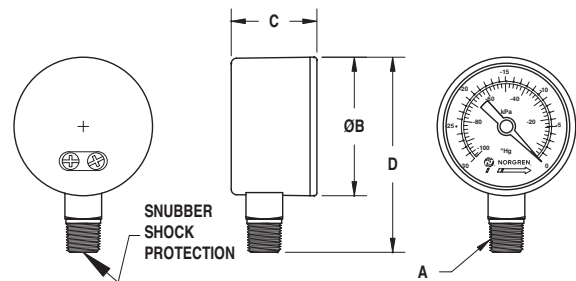

Vacuum Gauge: Bottom Mount

Part Number	Type	A Port Connection	B - Face Diameter in. (mm)	C in. (mm)	D in. (mm)	Weight oz (g)
NVG-150	Dry	1/8 NPT	1.62 (41.1)	1.00 (25.4)	2.28 (57.9)	1.5 oz (43g)
NVG-150-GF	Glycerin filled	1/8 NPT	1.85 (47.0)	1.10 (27.9)	2.42 (61.5)	2.7 oz (77g)
NVG-200-SS	Dry	1/4 NPT	2.28 (57.9)	1.10 (27.9)	3.10 (78.7)	3.1 oz (88g)

Vacuum Gauge: Center Back Mount

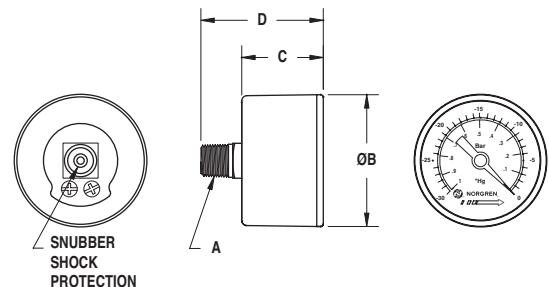

Part Number	Type	A Port Connection	B - Face Diameter in. (mm)	C in. (mm)	D in. (mm)	Weight oz (g)
NVG-150-CBM	Dry	1/8 NPT	1.62 (41.1)	1.00 (25.4)	1.50 (38.1)	1.6 oz (45g)

Vacuum Gauge: Panel Mount

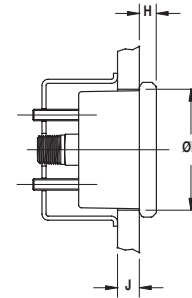
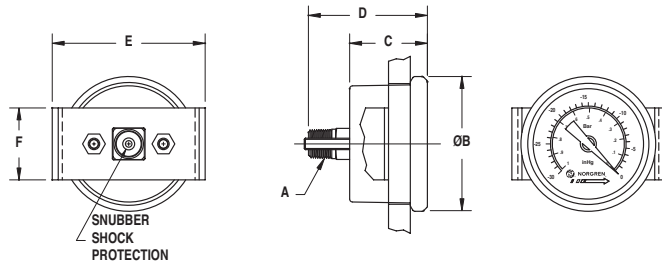

Part Number	Type	A Port Connection	B - Face Diameter in. (mm)	C in. (mm)	D in. (mm)	E in. (mm)	F in. (mm)	H in. (mm)	J - Max. Panel Thickness in. (mm)	K - Panel Cutout +/- .03 in. (mm)	Weight oz (g)
NVG-150-PM	Dry	1/8 NPT	1.85 (47.0)	1.07 (27.2)	1.64 (41.7)	2.11 (53.6)	0.99 (25.1)	0.24 (6.1)	0.30 (7.6)	1.67 (42.3)	3.3 oz (94g)
NVG-150-PMG	Glycerin filled	1/8 NPT	1.85 (47.0)	1.07 (27.2)	1.90 (48.3)	2.38 (60.5)	1.02 (25.9)	0.24 (6.1)	0.80 (20.3)	1.67 (42.3)	3.6 oz (102g)

Part Number	Type	Dial Size	Dual Scale Dial Range	Case	Bezel	Crystal	Bourdon Tube	Movement and Connection	Shock Protection	Accuracy
Lower Mount										
NVG-150	Dry	1.50"	0 to 30"Hg (0 to -1 bar)	Black ABS	None	Snap-on polycarbonate	Phosphor Bronze	Brass	0.5mm restrictor orifice	ASME B 40.1 Grade B (±3% of span)
NVG-150-GF	Glycerin filled			Stainless Steel	Stainless Steel	Polycarbonate				
NVG-200-SS	Dry	2.00"								
Center Back Mount										
NVG-150-CBM	Dry	1.50"	0 to 30"Hg (0 to -1 bar)	Black ABS	None	Snap-on polycarbonate				
Panel Mount										
NVG-150-PM	Dry	1.50"	0 to 30"Hg (0 to -1 bar)	Stainless Steel	Stainless Steel	Polycarbonate				
NVG-150-PMG	Glycerin filled									

Please note: Gauges should be ordered by model number as a separate line item as they are individually packaged for protection during shipping. For material availability, please consult factory.



- » High flow – no restrictions, maximum operating efficiency
- » 10 Micron filtration – protects generators and equipment from dirt and dust
- » 10 Models and sizes – fit most manufacturers vacuum generators and models
- » Easy to install and service – without removing from production line
- » Economical – pleated element's large surface area provides longer filter life. Low-cost replacement elements available.
- » Reliable, durable and worry-free operation – protects generators, valves, and equipment from dirty, dusty environments
 - Long Life
 - Longer service time
 - Less maintenance
 - Low operating costs



In-Line Vacuum Filters

Add Norgren's compact in-line vacuum filters to vacuum lines or air-supply lines to trap dirt and debris from entering the process, or to the exhaust port to capture airborne contaminants.

Norgren's pleated-element design offers a filter with significantly longer life and much higher flow capacity than non-pleated, porous plastic designs. The large surface area increases filter life while reducing maintenance costs.

Ideal for use in dirty, dusty applications:

- » **Material handling equipment**
- » **Printing**
- » **Paper and pulp**
- » **Wood chips**
- » **Powder and plastic dust**

The durable injection molded nylon and polycarbonate construction of the NVF models and the metal construction of the NVFC-1500F handle the most challenging environments. The 10-micron paper filters are rated for full vacuum to 150 PSI (10 bar) pressure.

You can use Norgren inline-filters in conjunction with any manufacturer's vacuum generators.

Please Note: Under normal conditions, Norgren's unique single-stage generators do not require vacuum filters for maximum operating efficiency.

Filter Options:

- » **Low (short) and tall (long) profiles**
- » **Male and female NPT connections**
- » **Plastic or metal filters**

IN-LINE VACUUM FILTERS



Dimensions

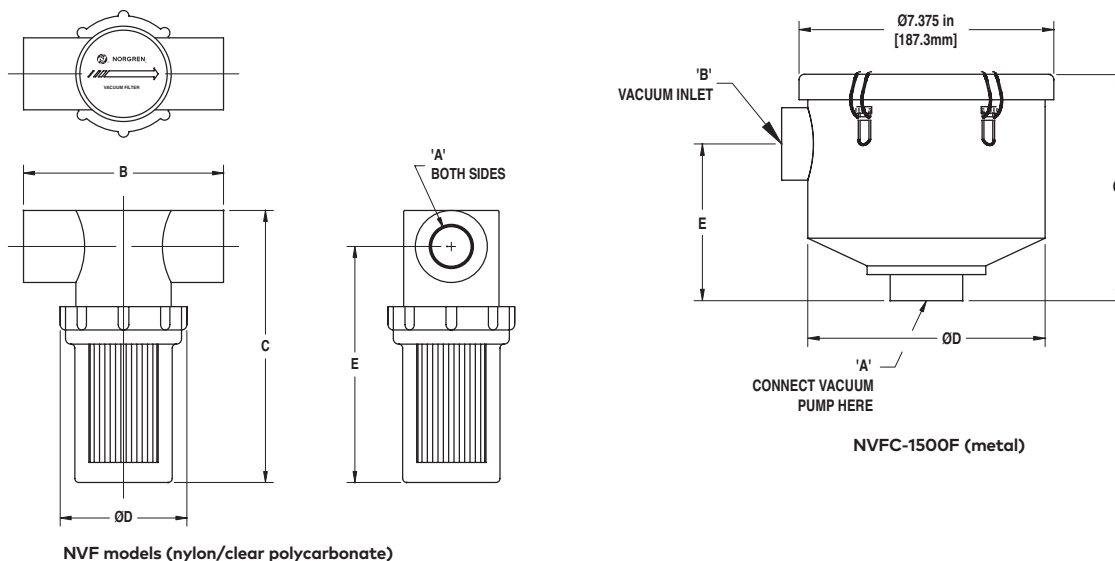

NVF models (nylon/clear polycarbonate)

Model #	Dimensions					Weight oz (g)	Housing	Replacement Elements oz (g)
	A in. (mm)	B in. (mm)	C in. (mm)	D in. (mm)	E in. (mm)			
NVF125LPF	1/8 NPT F	3.00 (76.2)	2.40 (61.0)	1.90 (48.3)	1.97 (50.0)	1.9 oz (54g)	Nylon & Clear Polycarbonate	RE1 - 3 Pack 0.8 oz (24.9g)
NVF125LPM	1/8 NPT M	3.04 (77.2)	2.40 (61.0)	1.90 (48.3)	1.97 (50.0)	1.9 oz (54g)		
NVF250LPM	1/4 NPT M	3.04 (77.2)	2.40 (61.0)	1.90 (48.3)	1.97 (50.0)	2.0 oz (57g)		
NVF250LPF	1/4 NPT F	3.00 (76.2)	2.40 (61.0)	1.90 (48.3)	1.97 (50.0)	2.0 oz (57g)		
NVF375LPM	3/8 NPT M	3.04 (77.2)	2.40 (61.0)	1.90 (48.3)	1.97 (50.0)	2.0 oz (57g)		
NVF250F	1/4 NPT F	3.00 (76.2)	3.77 (95.8)	1.90 (48.3)	3.38 (85.9)	2.0 oz (57g)		
NVF375F	3/8 NPT F	3.00 (76.2)	3.79 (96.3)	1.90 (48.3)	3.20 (81.3)	2.0 oz (57g)		
NVF500F	1/2 NPT F	3.58 (90.9)	5.06 (128.5)	2.93 (74.4)	4.46 (113.3)	5.6 oz (159g)	RE2 - 3 Pack 3.7 oz (115.1g)	
NVF750F	3/4 NPT F	3.58 (90.9)	5.06 (128.5)	2.93 (74.4)	4.46 (113.3)	5.6 oz (159g)		
NVF1000F	1 NPT F	4.94 (125.5)	6.50 (165.1)	4.10 (104.1)	5.59 (142.0)	7.8 oz (221g)	RE3 - 3 Pack 7.0 oz (217.7g)	
NVF1500F	1 1/2 NPT F	5.08 (129.0)	8.06 (204.7)	4.10 (104.1)	6.94 (176.3)	7.8 oz (221g)	RE4 - 3 Pack 7.2 oz (223.9g)	
NVFC-1500F	1 1/2 NPT F	1 1/2 NPT F	7.31 (185.7)	6.81 (173.0)	6.50 (165.1)	4lb 5oz (2.0kg)	Metal	RE-848 - 1 Pack 14.6 oz (454.1g)

How to Specify:

When ordering specify model number: **NVF1500F**.

Consider size of tubing, fittings and generator. Consult factory for assistance.

Warning

These products are intended for use in industrial systems only. Do not use these products where pressures and temperatures can exceed those listed under Specifications.

Before using these products with fluids other than those specified, for nonindustrial applications, life-support systems, or other applications not within published specifications, consult Norgren.

Through misuse, age, or malfunction, components used in fluid power systems can fail in various modes. The system designer is warned to consider the failure modes of all component parts used in fluid power systems and to provide adequate safeguards to prevent personal injury or damage to equipment in the event of such failure modes.

System designers must provide a warning to end users in the system instructional manual if protection against a failure mode cannot be adequately provided. System designers and end users are cautioned to review specific warnings found in instruction sheets packed and shipped with these products, or posted on the Norgren website under "Downloads." System designers should also provide for all OSHA requirements including Title 29 CFR 1910.147 Lockout/Tagout.

It should be recognized that warnings are valid for any product, regardless of manufacturer, and are not restricted to products manufactured by Norgren. Norgren's reputation for product quality and performance is well established. We feel we have the additional obligation to provide information or warnings to customers to assist them in applying our products in a reasonable and safe manner.

Proposition 65: These products may contain chemicals known to the state of California to cause cancer, or birth defects, or other reproductive harm.

Warranty

Items sold by Norgren are warranted to be free from defects in materials and workmanship for a period of two years* from the date of invoice, provided said items are used according to Norgren's recommended usages. NORGREN'S LIABILITY IS LIMITED TO THE REPAIR OF, REFUND OF PURCHASE PRICE PAID FOR, OR REPLACEMENT IN KIND OF, AT NORGREN'S SOLE OPTION, ANY ITEMS PROVED DEFECTIVE, PROVIDED THE ALLEGEDLY DEFECTIVE ITEMS ARE RETURNED TO NORGREN PREPAID. THE WARRANTIES EXPRESSED ABOVE ARE IN LIEU OF AND EXCLUSIVE OF ALL OTHER WARRANTIES. THERE ARE NO OTHER WARRANTIES, EXPRESSED OR IMPLIED, EXCEPT AS STATED HEREIN.

THERE ARE NO IMPLIED WARRANTIES OF MERCHANTABILITY OR FITNESS FOR A PARTICULAR PURPOSE, WHICH ARE SPECIFICALLY DISCLAIMED. NORGREN'S LIABILITY FOR BREACH OF WARRANTY AS HEREIN STATED IS THE EXCLUSIVE REMEDY, AND IN NO EVENT SHALL NORGREN BE LIABLE OR RESPONSIBLE FOR INCIDENTAL OR CONSEQUENTIAL DAMAGES, EVEN IF THE POSSIBILITY OF SUCH INCIDENTAL OR CONSEQUENTIAL DAMAGES HAS BEEN MADE KNOWN TO NORGREN.

Norgren reserves the right to discontinue manufacture of any product or change product materials, design, or specifications.



1	MODULAR VENTURI SINGLE STAGE VACUUM GENERATORS	
2	CYLINDRICAL VENTURI VACUUM GENERATORS	
3	VARIABLE VACUUM GENERATORS	
4	HIGH FLOW VACUUM / BLOWER GENERATORS	
5	MATERIAL TRANSFER VACUUM GENERATORS	
6	VACUUM CUPS & FITTINGS	
7	END-OF-ARM TOOLING	
8	ACCESSORIES	

Norgren, Bimba, Buschjost, FAS, Herion, Kloehn and Maxseal are registered trademarks of Norgren companies.

Due to our policy of continuous development, Norgren reserve the right to change specifications without prior notice.

z8551CT us/01/2024

Selected Images used under license from Shutterstock.com



Incorporating

- BIMBA**
- BUSCHJOST**
- FAS**
- HERION**
- KLOEHN**
- MAXSEAL**