

**Hahn Part Number: 28-01ACR**  
**G 10 23 0100 1 0290 AU19 AU19 00300N /5**

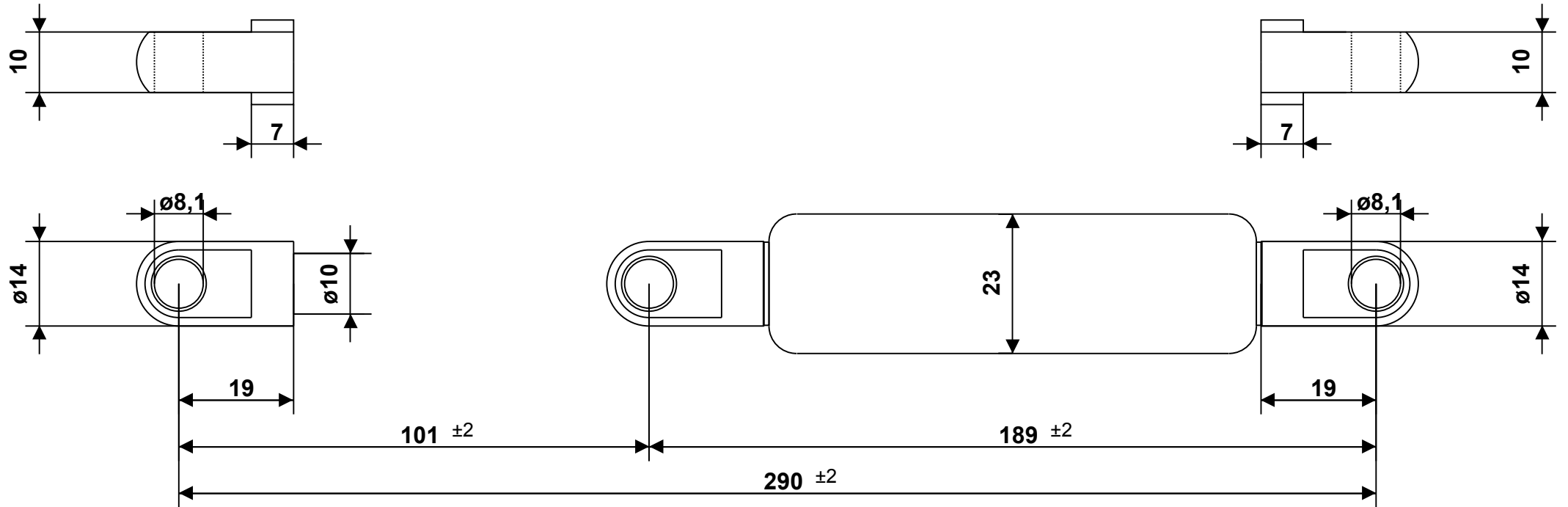

Intended for internal use and customer / Tolerance of ext. length: +/- 2mm - Dimensions without tolerance: per DIN ISO 2768-1 -c (ISO 2768 -c) - For Information Only  
 Force tolerance: F1 >= 1000N: +/- 5%; < 1000N: +/- 10%, min.: +/- 10N, max.: +/- 50N - Unregistered Copy, Print-out or file not subject to modification service.  
 End fitting orientation is random and not represented by drawing unless specified - Observe disposal instructions - Not true to scale



Please note our technical instructions

Assembly/storing with piston rod down

22. Oct 2025

Auto-Printservice

No opening-no heating-high pressure

Made in Germany

Part

Dimension

Material / Surface

Fitting

Progr.:38,40 %

Drawing owned by Hahn Gasfedern GmbH

Piston rod

Ø10mm

Stahl, hartverchromt

AU19 M8 Ø8.1 t=10

info@hahn-gasfedern.de

Cylinder

Ø23mm

Stahl,schwarz

AU19 M8 Ø8.1 t=10

www.hahn-gasfedern.de

Configuration ID : 10075582-