

AUTOTRASFORMATORE 3-042-400

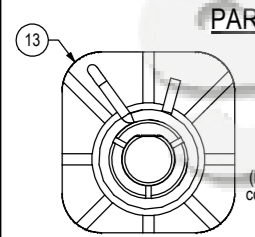

**PART. "K"**  
 WRAPPER MUST BE INSERTED WITH FINS TOWARD THE SIDE MILLED OF THE SHAFT  
 (La fascetta deve essere inserita con le alette orientate verso il lato fresato dell'albero)  
 ELCO logo

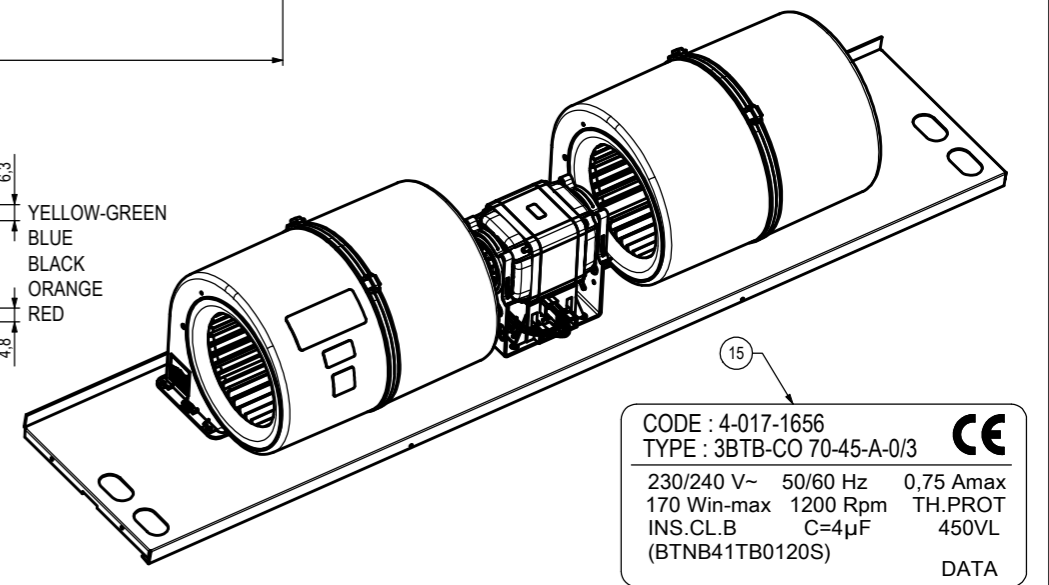
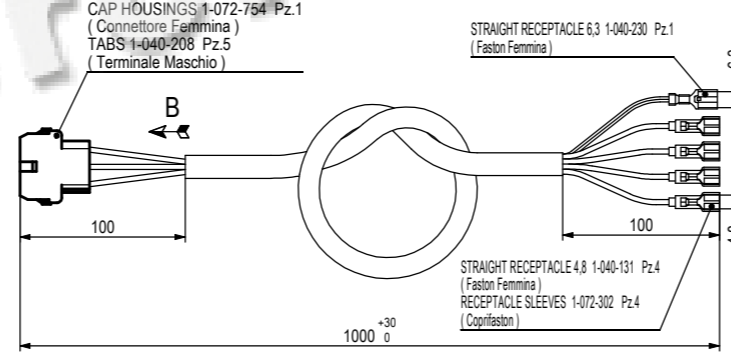
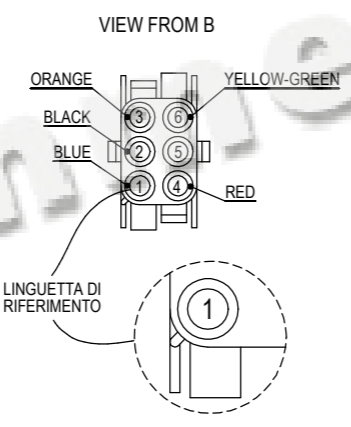

CODE : 4-017-1656  
 TYPE : 3BTB-CO 70-45-A-0/3  
 230/240 V~ 50/60 Hz 0,75 Amax  
 170 Win-max 1200 Rpm TH.PROT  
 INS.CL.B C=4µF 450VL  
 (BTN41TB0120S)  
 DATA

MOTOR (Motore)	CLASS "B" - SLEEVE BEARING MANUFACTURED (Classe "B" - esecuzione a bronze)
HOUSING (Coclea)	THERMOPLASTIC MATERIAL (Materiale Plastico)
FAN-DECK SUPPORT (Supporto gruppo Vent.)	GALVANIZED SHEET IRON (Lamiere Zincata)
BLOWERS (Ventole) No.2 (Ø146x226)	THERMOPLASTIC MATERIAL (Materiale Plastico)
ELECTRICAL SPECIFICATION No. (Prescrizione per controllo elettrico)	G.2227/1E

2-335-1940  
 SUPPLIED SEPARATELY  
 (Prolunga Fornita a Parte)

- 1) TO POSITION THE HOUSING FIXING SCREWS IN ACCORDANCE EL.UN.0089 (Posizionare le viti di fissaggio coclea secondo normativa EL.UN.0089)
- 2) TO TIGHTEN THE HOUSING FIXING SCREWS ON PLATE WITH TORQUE 15-17 Kgcm (Serrare le viti di fissaggio coclea con una coppia di 15-17-Kgcm)
- 3) BLOWER MUST BE CENTERED IN TO THE HOUSING (Controllare la scentratura della ventola, massimo consentito 2mm)
- 4) TO CONTROL ON BOTH HOUSING ARE MOUNTED THE FIXING ORINGS (Controllare che su entrambi i gruppi coclea siano montati gli oring di fissaggio)

Rel	Date	Description	Executed	Checked
B	14-07-2016	Graphic updating: changed faston earth position on BT motor (Aggiornam. grafico: variato posizione faston di terra su motore BT) RdM 16/0014 A.T.	D. Riboldi	E. Crippa
A	29-03-2013	TOLTO PROLUNGA COLLEGATA ALL'AUTOTRAF. AGGIUNTO PROLUNGA FORNITA A PARTE - SOSTITUITO TARGHETTA AUTOTRAF.	Pedrin R.	Sirtori

For dimension without tolerance see standard UNI EN 22768-mK	Treatment	A2
Material	GR. VENT. 230/240 V 50/60 Hz	Weight gr.
Drawn Pedrini R.	TYPE : 3BTB-CO 70-45-A-0/3	Release B
Date 08/09/2010	Ref. No. 4-017-1553	
Check T. Sirtori	4-017-1656	
Scale		

MODIFICATIONS

DRAWING MADE BY CAD HAND MADE MODIFICATIONS ARE FORBIDDEN

THIS DRAWING IS OUR PROPERTY. ANY PARTIAL OR COMPLETE COPY IS FORBIDDEN WITHOUT PREVIOUS WRITTEN AUTHORISATION