

FSO-BF type seal - flush diaphragm

Design description

The FSO-BF construction has a seal body that is made of bar stock or forged material. The weld between the seal body and the diaphragm is a wetted part and therefore diaphragm materials are mostly chosen the same as the body material. The FSO-BF is recommended when special body or flange material grades are required. FSO-BF is typically used in combination with (differential) pressure transmitters for applications such as level, flow and (absolute) pressure measurement.

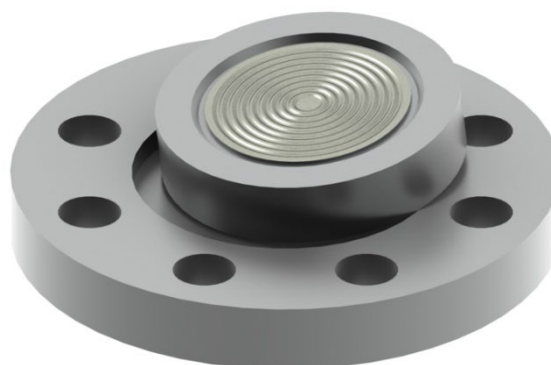

Body vs diaphragm combinations

The diaphragm is TIG-welded to the body and is designed to have the best performance for the specific size. This means that the flexibility and shape is carefully tested and measured. The standard thickness of diaphragm foil is 0.075mm

Body Material	Diaphragm material		
	General name	UNS	Wst.
AISI 316(L)	AISI 316L	S31603	1.4404
	AISI 304L	S30400	1.4306
	AISI 321	S32100	1.4541
	AISI 316 UG	S31603	1.4435
	Alloy C276	N27600	2.4810
AISI 304L	AISI 304L	S30400	1.4306
AISI 310 MoLn	25-22-2 LMN	S31050	1.4466
AISI 316 UG	AISI 316 UG	S31600	1.4435
AISI 321	AISI 321	S32100	1.4541
AISI 904(L)	AISI 904L	N08904	1.4539
Alloy 20	Alloy 20	N08020	2.4660
Alloy 400	Alloy 400	N04400	2.4360
Alloy 600	Alloy 600	N06600	2.4816
Alloy 625	Alloy 625	N06625	2.4856
Alloy 825	Alloy 825	N08825	2.4858
Alloy B2	Alloy B2	N10665	2.4617
Alloy C-22	Alloy C-22	N06022	2.4602
Alloy C-276	Alloy C-276	N10276	2.4810
Duplex F44	254 SMO (6Mo)	S31254	1.4547
Duplex F51/F60	Duplex 2205	S32205	1.4462
Duplex F53	Super Duplex 2507	S32750	1.4410
Duplex F55	Super Duplex 2507	S32750	1.4410
Nickel 201	Nickel 201	N02201	2.4068
Safurex®*1	Safurex®	S32906	1.4477
Titanium Gr. 2	Titanium Gr. 1	R50250	2.7025
Zirconium 702	Zirconium 702	R60702	-

Not all materials are available for all standards, size or class due to stress restrictions

Flange size, rating and facings - ASME B16.5

ASME B16.5			
Size	Rating	Facing	Roughness
1" to 4"	cl. 150 - cl. 2500	RF, LMF, FF, LFF	Ra 3.2-6.3 µm
		RJF	Ra <1.6 µm
		SMF, SFF, STF, LTF, SGF, LGF	Ra <3.2 µm

EN 1092-1			
Size	Rating	Type	Roughness
DN20 to DN100	PN10-400	A, B1, E, F	Ra 3.2-12.5 µm
		B2, C, D, G, H	Ra <0.8-3.2 µm

API 6A Spec 2018			
Size	Rating	Facing	Roughness
1-13/16" to 3-1/16"	69 – 138 MPa	6BX – RJF	Ra <1.6 µm
2-1/16" to 3-1/8"	13.8 – 34.5 MPa	6B-RJF	Ra <1.6 µm

JIS B2220			
Size	Rating	Type	Roughness
DN25 to DN100	10-20K	RF	Ra 3.2-12.5 µm

Cover flanges

FSO seals are equipped with a cover flange of a different material than the seal body material. The material can be selected based on pressure/temperature rating, corrosive ambient conditions, or other influencing conditions. Examples are A350 LF2, A105, F55, AISI 321, or in combination with one of the polymer coatings.

Gold coatings

Several types of gold coating can be applied on the seals. The selection possibilities are:

- 25 µm chemical resistance (diaphragm + facing)
- 40 µm chemical resistance (diaphragm + facing)
- 25 µm Hydrogen protection (diaphragm only)
- 40 µm Hydrogen protection (diaphragm only)

-> See datasheet "Gold coatings"

Polymer coatings

Polymer coatings come in several types. The technical data on thickness and temperature limitation can be found in datasheet "polymer solutions" The applicable selection on BF seals are:

- PTFE coating
- ECTFE (Halar®) coating
- PFA coating
- FEP coating
- PTFE sheet

-> See datasheet "Polymer solutions"

Capillary tube and armor (protection)

The standard capillary mounting position is top side (axial) of the seal. The standard tube material is TP316 (316SS), optionally available in Alloy 400. There are three options in ID of the capillary; 2mm, 1mm, and 0.7mm. Badotherm capillaries are always protected against mechanical forces by armor. This doubled shielded armor consist is standard AISI 304, and optionally AISI 316. Additionally, the armor could be protected with a PVC sleeve in white, black, optionally with ATEX114 approval to protect against dust and water ingress and possibly corrosive ambient atmosphere.

-> See datasheet "Capillary lines"

Flush rings and flush flanges

Badotherm offers matching flush rings or flush flanges to their diaphragm seal. On request equipped with blind plugs, vent plug and or flushing / draining needle valves, which can be fitted or welded to the complete construction.

-> See datasheet flush rings

-> See datasheet flush flanges

-> See datasheet reducer flanges

Lifting handles

Larger sizes and ratings of diaphragm seals can weigh up to 50 kg. Handling and installation can become a challenge. As from 15kg it is recommended to apply a set of lifting handles, welded on the sides of the flange of the seal, or lifting lugs screwed to the flange. This can be used to handle it easier and install it in a safer way or have attach lifting tools to it.

Material Certification

Material traceability and related certification are applicable for all process wetted parts. Material certification possibilities depend on the type of seal, the assembly construction and the materials used. Material certification is in accordance with EN10204 3.1.

Additional material certification and testing can be provided on request, such as Positive Material Identification (PMI), Intergranular corrosion (IGC) testing, material certification in accordance with EN10204 3.2, NACE conformity for ISO-15156 (MR-0175) and/or ISO-17945 (MR-0103), NORSOK M-630 and many more.

-> Please note that the responsibility for material selection always rests with the user.

Flange Marking & Traceability

All flanges are marked by the forging shop with heat number, material designation, size, and rating. Badotherm adds a Badotherm reference number and the manufacturers name to the flange for traceability purposes.

Flanges and origin

The seal parts are made from forged materials according to the applicable standards. The standard sourcing of flanges is of international origin. Optionally regional preference can be requested, for example materials from EU origin.

Testing

All seals are helium tested according the ISO 20485 test procedure A.3 up to 10^{-9} mbar l/s before used on a diaphragm seal application.

-> See datasheet "Diaphragm Seal testing"

Cleanliness of the wetted parts

All parts are standard cleaned from excessive oil and grease. When additional requirements are needed, the parts can be cleaned according customer requirements and cleaning specifications.

Limitations

There are some limitations in mounting the FSO-BF to pressure instruments.

- ≤1.5" (DN25) can have maximum capillary length 6 mtr
- Direct mount is always with 80mm extension tube.

Gaskets

Sizes of the diaphragm area are designed to match the gaskets used between the process and seal or flush ring. For the ASME B16.5 RF flanges the ASME B16.20 is used for dimension restriction to ensure both the spiral and grooved gaskets are fully supported by the serrated area. For the EN type B1 flanges the gasket dimensions are matching the sizes of the EN 1514-2. The size "G" in the tables refer to the start of the gasket surface.

Example performance calculation

Whether a diaphragm seal can be used for a specific measurement, depends on the size of the diaphragm. That size is restricted by the size of the diaphragm seal.

For pressure transmitters, Badotherm offers an online performance calculation tool to calculate its performance and to ensure that the diaphragm size is suitable for your measurement.

The table below presents the minimum span of the respective diaphragm sizes with standard process conditions. As rule of thumb, a TPE of max 5% is often considered acceptable, but it depends per situation.

Minimum span table

dD	AP/GP	DP
23.5mm	17.5 bar	na
32mm	11 bar	1850 mbar
44mm	1575 mbar	255 mbar
57mm	415 mbar	70 mbar
72mm	155 mbar	30 mbar
81mm	110 mbar	20 mbar

Pressure transmitter; ambient temperature -10...+30°C; process temperature 100°C with BSO 22 fill fluid; 3 meter capillary; ID 1mm, DP both sides mounted with seal

See the general overview of all diaphragm sizes with several standard situations and in combination with Badotherm pressure gauges.

Retaining screws

The cover flange and the seal part are fixed together hexagon socket cap screws. The length of the screws depends on the thickness of the cover flange.

Grade bolt	Type	Size
A2-70 (ISO 3506-1)	ISO 4762	M6

Standards used

Design Standards

Standard	Description
ASME B16.5 - 2020	Pipe flanges and flanged fittings
ASME B16.20 - 2017	Metalic gaskets for flanges
EN 1092-1 - 2018	Circular flanges for pipes
EN 1514-2 - 2021	Dimensions of gaskets
API 6A 21 st Edition ISO 10423 - 2022	International Standard for Petroleum and Natural Gas Industries
JIS B2220 - 2012	Japanese Flange Standard
GOST 33259 - 2015	Russian Flange Standard

Test Standards

Standard	Description
ISO 20485 - 2018	Non-destructive testing - Leak testing - Tracer gas method

Material Standards

Standard	Description
NACE MR0175/MR0103 ISO 15156 - 2020	use in H ₂ S-containing environments in oil and gas production
NORSOK M-630 - 2010	specification for use in pipelines
ASTM standards	Material specific standards

Certification Standards

Standard	Description
EN 10204 - 2017	Inspection documents
ASME IX	Welding, Brazing, and Fusing Qualifications
ISO 15610	Specification and qualification of welding procedures for metallic materials

Roughness conversion

The specific flange norm all relates to specific roughness value for surface finish and flange finish. Below table can be used for conversion between the average roughness (Ra) in micrometers (µm) and microinch (µin)

µm	µin
0.8	32
1.6	63
3.2	125
6.3	250

Dimensions table: ASME B16.5 RF facing

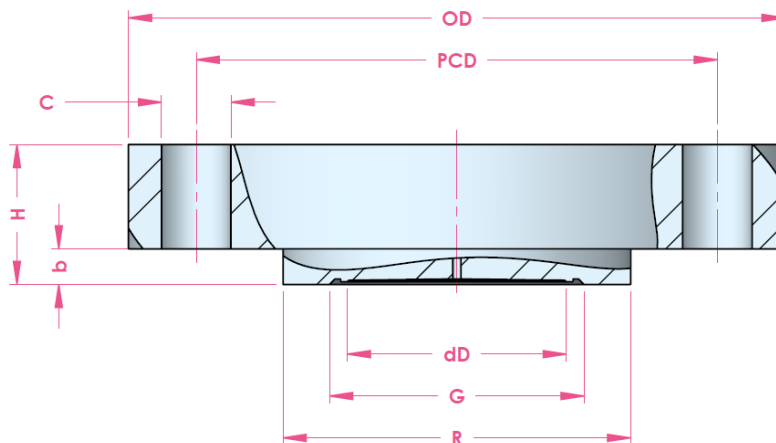

size	rating	OD	b	H	PCD	C / pcs	dD	R	f	G	weight
1"	cl. 150	108.0	18.0	30.7	79.2	15.9 / 4x	23.0	50.8	1.5	31.8	1.2
	cl. 300	124.0		33.7	88.9	19.1 / 4x			6.4		1.7
	cl. 400-600			35.5							1.9
	cl. 900-1500	149.0		46.4	101.6	25.4 / 4x			3.9		
1.25"	cl. 150	117.0	18.0	32.2	88.9	15.9 / 4x	32.0	63.5	1.5	41.5	1.7
	cl. 300	133.0		35.5	98.6	19.1 / 4x			6.4		2.3
	cl. 400-600			38.6						2.6	
	cl. 900-1500	159.0		46.4	111.1	25.4 / 4x			39.8	4.6	
1.5"	cl. 150	127.0	18.0	33.9	98.6	15.9 / 4x	44.0	73.0	1.5	52.4	2.1
	cl. 300	155.0		37.0	114.3	22.3 / 4x			6.4		3.3
	cl. 400-600			40.4						3.7	
	cl. 900-1500	178.0		49.8	124.0	28.6 / 4x			41.5	6.4	11.3
2"	cl. 150	152.0	18.0	30.5	120.6	19.1 / 4x	57.0	91.9	1.5	70.2	3.0
	cl. 300	165.0		33.6	127.0	19.1 / 8x			6.4		3.9
	cl. 400-600			38.4						4.6	
	cl. 900-1500	216.0		51.1	165.1	25.4 / 8x			55.4	10.6	
3"	cl. 150	190.0	13.0	35.4	152.4	19.1 / 4x	81.0	127.0	1.5	93.0	6.2
	cl. 300	210.0		39.9	168.1	22.4 / 8x			6.4		8.2
	cl. 400-600			44.8							9.4
	cl. 900	241.0		51.1	190.5	25.5 / 8x			13.9		
	cl. 1500	267.0		60.7	203.2	31.9 / 8x			20.0		
	cl. 2500	305.0		79.5	228.6	35.0 / 8x			36.3		
4"	cl. 150	229.0	13.0	35.4	190.5	19.2 / 8x	81.0	157.2	1.5	93.0	9.1
	cl. 300	254.0		43.2	200.2	22.4 / 8x			6.4		13.6
	cl. 400			48.1							15.2
	cl. 600	273.0		51.1	215.9	25.5 / 8x			19.0		
	cl. 900	292.0		57.5	235.0	31.9 / 8x			23.3		
	cl. 1500	311.0		67.0	241.3	35.0 / 8x			31.4		
cl. 2500	356.0	89.2	273.0	41.4 / 8x	56.0						

All dimensions in mm, weight in kg

Dimensions table: ASME B16.5 RJF facing

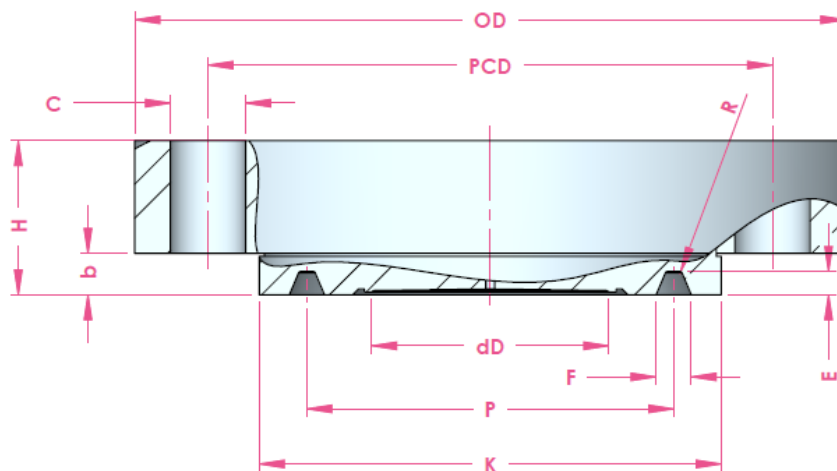

size	rating	OD	b	H	PCD	Cb/pcs	dD	K	E	F	P	R	Ring #	Weight
1"	cl. 150	108.0	18.0	30.7	79.2	15.9 / 4x	32.0	63.5	6.35	8.74	47.62	0.8	15	1.3
	cl. 300	124.0		33.7	88.9	19.1 / 4x		69.8					16	2.0
	cl. 400-600	149.0		35.5	88.9	19.1 / 4x		71.4					18	2.1
	cl. 900-1500	159.0		46.4	101.6	25.4 / 4x		82.6					21	4.2
1.25"	cl. 150	117.0	18.0	32.2	88.9	15.9 / 4x	32.0	73.2	6.35	8.74	57.15	0.8	17	1.8
	cl. 300	133.0		35.5	98.6	19.1 / 4x		79.2					18	2.6
	cl. 400-600	159.0		38.6	98.4	19.1 / 4x		81.0					21	2.9
	cl. 900-1500	184.0		46.4	111.1	25.4 / 4x		102.0					24	4.9
1.5"	cl. 150	127.0	18.0	33.9	98.6	15.9 / 4x	44.0	82.6	7.92	11.91	72.24	0.8	19	8.6
	cl. 300	155.0		37.0	114.3	22.3 / 4x		90.4					20	2.2
	cl. 400-600	178.0		40.4	114.3	22.3 / 4x		91.9					23	3.6
	cl. 900-1500	203.0		49.8	124.0	28.6 / 4x		114.0					26	4.0
2"	cl. 150	152.0	13.0	30.5	120.6	19.1 / 8x	57.0	102.0	6.35	8.74	82.55	0.8	22	6.8
	cl. 300	165.0		33.6	127.0	19.1 / 8x		108.0					23	3.2
	cl. 400-600	216.0		38.4	127.0	19.1 / 8x		124.0					24	4.1
	cl. 900-1500	235.0		51.1	165.1	25.4 / 8x		133.0					26	4.8
3"	cl. 150	190.0	13.0	35.4	152.4	19.1 / 4x	81.0	133.0	6.35	8.74	114.30	0.8	29	17.1
	cl. 300	210.0		39.9	168.1	22.3 / 8x		146.0					31	6.3
	cl. 400-600	241.0		44.8	168.3	22.3 / 8x		156.0					35	8.6
	cl. 900	267.0		51.1	190.5	25.4 / 8x		168.0					39	9.8
4"	cl. 1500	267.0	13.0	60.7	203.2	31.8 / 8x	81.0	168.0	9.53	13.49	127.00	0.8	32	21.0
	cl. 2500	305.0		79.5	228.6	34.9 / 8x		175.0					35	21.0
	cl. 150	229.0		35.4	190.5	19.1 / 8x		171.0					36	9.4
	cl. 300	254.0		43.2	200.2	22.3 / 8x		175.0					37	14.1
	cl. 400	273.0		48.1	200.0	25.4 / 8x		175.0	37	15.7				
	cl. 600	292.0		51.1	215.9	25.4 / 8x		181.0	37	19.4				
	cl. 900	292.0		57.5	235.0	31.8 / 8x		194.0	39	24.0				
	cl. 1500	311.0		67.0	241.3	34.9 / 8x		203.0	39	32.5				
cl. 2500	356.0	89.2	273.0	41.3 / 8x	203.0	38	57.4							

All dimensions in mm, weight in kg

Dimensions table: EN 1092-1 B1 type

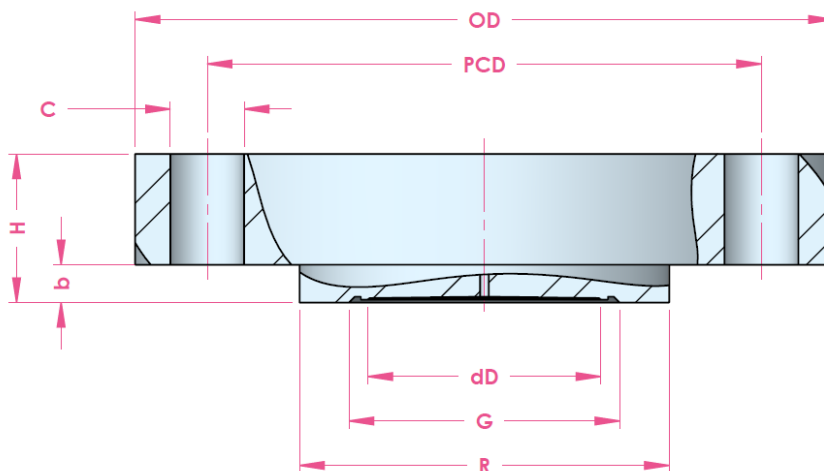

size	rating	OD	b	H	PCD	C / pcs	dD	R	G	Weight	
DN20	PN10-40	105.0	18.0	34.0	75.0	14.0 / 4x	23.0	58.0	33.8	1.4	
	PN63-100	130.0		38.0	90.0	18.0 / 4x				2.4	
DN25	PN10-40	115.0		34.0	85.0	14.0 / 4x	32.0	68.0	41.0	1.8	
	PN63-100	140.0		40.0	100.0	18.0 / 4x				3.1	
	PN160			42.0						3.5	
	PN250	150.0		46.0	105.0	22.0 / 4x				3.9	
	PN320	160.0		52.0	115.0					5.3	
	PN400	180.0		56.0	130.0	26.0 / 4x				7.3	
DN32	PN10-40	140.0		31.0	100.0	18.0 / 4x	32.0	78.0	41.5	2.5	
	PN63-100	155.0		37.0	110.0	22.0 / 4x				3.8	
DN40	PN10-40	150.0		31.0	110.0	18.0 / 4x	44.0	88.0	55.4	2.9	
	PN63-100	170.0		39.0	125.0	22.0 / 4x				4.8	
	PN160			46.0						5.3	
	PN250	185.0		52.0	135.0	26.0 / 4x				7.3	
	PN320	195.0	56.0	145.0	8.9						
	PN400	220.0	66.0	165.0	30.0 / 4x	13.9					
DN50	PN10-40	165.0	33.0	125.0	18.0 / 4x	57.0	102.0	70.2	3.6		
	PN63	180.0	39.0	135.0	22.0 / 4x				5.3		
	PN100	195.0	41.0	145.0	26.0 / 4x				6.4		
	PN160		43.0						7.1		
	PN250	200.0	51.0	150.0	26.0 / 8x				8.7		
	PN320	210.0	55.0	160.0					10.7		
	PN400	235.0	65.0	180.0	30.0 / 8x				16.1		
DN80	PN10-40	215.0	37.0	160.0	18.0 / 8x	81.0	138.0	93.0	6.6		
	PN63		39.0	170.0	22.0 / 8x				8.3		
	PN100	230.0	45.0	180.0	26.0 / 8x				10.3		
	PN160	230.0	49.0	180.0					11.2		
	PN250	255.0	59.0	200.0	30.0 / 8x				17.7		
	PN320	275.0	68.0	220.0					24.6		
	PN400	305.0	81.0	240.0	33.0 / 8x				36.9		
DN100	PN10-16	220.0	33.0	180.0	18.0 / 8x	81.0	158.0	93.0	7.0		
	PN25-40	235.0	37.0	190.0	22.0 / 8x				9.0		
	PN63	250.0	41.0	200.0	26.0 / 8x				12		
	PN100	265.0	49.0	210.0	30.0 / 8x				15.4		
	PN160		53.0				17.4				
	PN250		300.0				67.0		235.0	33.0 / 8x	29
	PN320		335.0				78.0		265.0	36.0 / 8x	42.9
	PN400	370.0	93.0	295.0	39.0 / 8x		64				

All dimensions in mm, weight in kg

Dimensions table: JIS 2220 RF

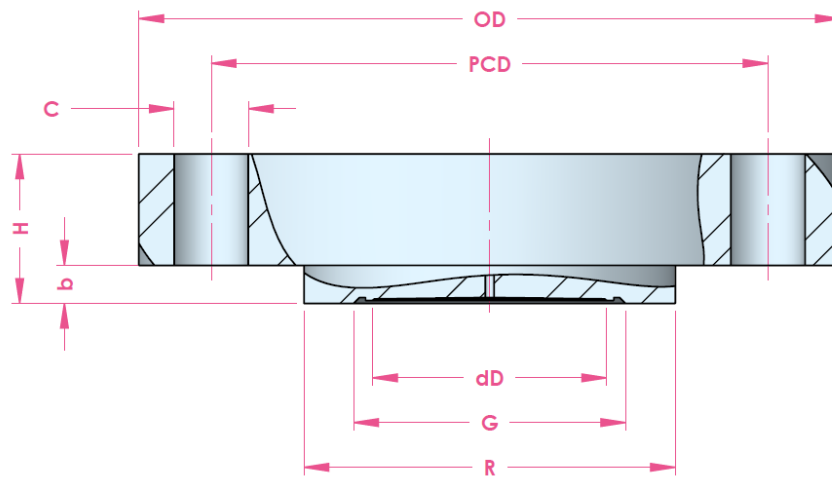

Size	rating	OD	dD	b	H	PCD	C / pcs	R	G	Weight		
25	10K	125.0	32.0	18.0	30.0	90.0	19.0 / 4x	67.0	40.0	2.2		
	16K									2.2		
	20K									3.4		
32	10K	135.0	44.0		32.0	100.0		19.0 / 4x	76.0	50.6	2.5	
	16K										2.5	
	20K										3.7	
40	10K	140.0	44.0		32.0	105.0	19.0 / 4x		81.0	55.4	2.7	
	16K										2.7	
	20K										3	
50	10K	155.0	57.0		32.0	120.0		19.0 / 8x	96.0	68.5	3.2	
	16K										3.2	
	20K										3.5	
80	10K	185.0	81.0	34.0	150.0	23.0 / 8x	126.0		93.0	5.2		
	16K	200.0								6.5		
	20K	7										
90	10K	195.0		34.0	160.0		170.0	23.0 / 8x		136.0	93.0	5.8
	16K	7.3										
	20K	8.4										
100	10K	210.0	40.0	175.0	185.0	23.0 / 8x	151.0		93.0	6.9		
	16K	9.1										
	20K	9.8										

All dimensions in mm, weight in kg.

Dimensions table: API 6A – Type 6BX

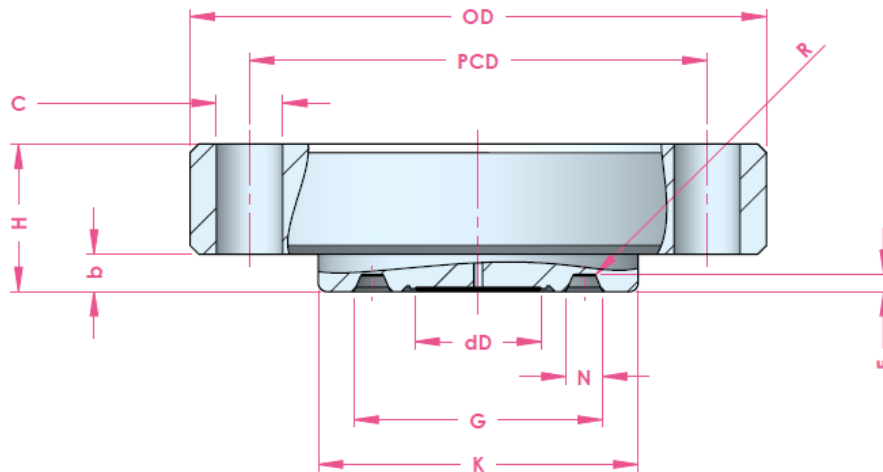

size	rating	OD	b	H	PCD	C / pcs	dD	K	E	N	G	ring	Weight
1-13/16"	69MPa	187.0	18.0	60.1	146.1	23.0 / 8x	32.0	105.0	5.56	11.84	77.77	BX-151	9.1
	103,5MPa	208.0		63.3	160.3	26.0 / 8x		106.0					12.3
	138MPa	257.0		81.5	203.2	29.0 / 8x		117.0					25.3
2-1/16"	69MPa	200.0	13.0	57.1	158.8	23.0 / 8x	44.0	111.0	5.95	12.65	86.23	BX-152	10.6
	103,5MPa	222.0		63.8	174.6	26.0 / 8x		114.0					14.8
	138MPa	287.0		84.5	230.2	32.0 / 8x		132.0					35.1
2-9/16"	69MPa	232.0	13.0	64.2	184.2	26.0 / 8x	57.0	133.0	6.75	14.07	102.77	BX-153	16.3
	103,5MPa	254.0		70.2	200.0	29.0 / 8x		133.0					22.2
	138MPa	325.0		92.4	261.9	35.0 / 8x		151.0					50.3
3-1/16"	69MPa	270.0	13.0	71.4	215.9	29.0 / 8x	72.0	152.0	7.54	15.39	119.00	BX-154	25.3
	103,5MPa	287.0		77.3	230.2	32.0 / 8x		154.0					32.1
	138MPa	357.0		98.8	287.3	39.0 / 8x		171.0					64.7

All dimensions in mm, weight in kg

Dimensions table: API 6A – Type 6B

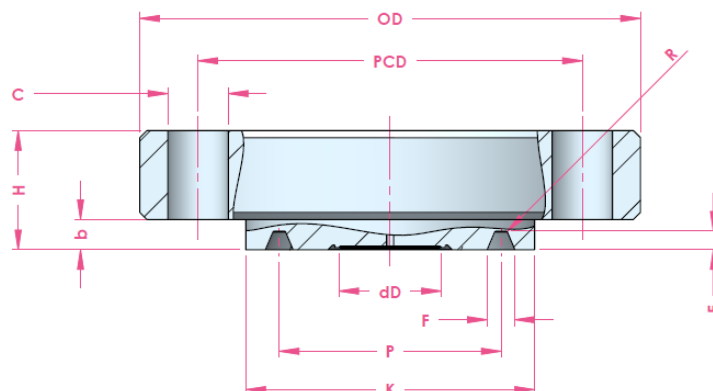

size	rating	OD	b	H	PCD	C / pcs	dD	K	E	F	P	ring	Weight		
2-1/16"	13.8MPa	165.0	13.0	46.4	127.0	20.0 / 8x	44.0	108.0	7.9	11.91	82.55	R or RX-23	5.3		
	20.7MPa	216.0		59.1	165.1	23.0 / 8x		124.0			95.25	R or RX-24	12.4		
	34.5MPa			59.1			127.0	101.60			R or RX-26	7.8			
2-9/16"	13.8MPa	191.0		49.6	149.2	29.0 / 8x	72.0	137.0			7.9	11.91	107.95	R or RX-27	17.2
	20.7MPa	244.0		62.3	190.5	23.0 / 8x		146.0					123.83	R or RX-31	10.6
	34.5MPa			62.3	190.5	26.0 / 8x	156.0	136.53					R or RX-35	23.5	
3-1/8"	13.8MPa	210.0	52.7	168.3	32.0 / 8x	81.0	168.0	7.9	11.91	123.83			R or RX-31	15.8	
	20.7Mpa	240.0	59.1	190.5	20.0 / 8x		156.0			136.53			R or RX-35	23.5	
	34.5MPa	267.0	68.6	203.2	26.0 / 8x	168.0	136.53			R or RX-35			23.5		

All dimensions in mm

Change log

Date	Change
30-3-2020	1.5" cl 2500 dimension "P" in RJF changed.
7-5-2020	Removed cap side (Radial) from capillary paragraph
8-3-2021	Updated dimension tables according ASME B16.5:2020
5-5-2021	Sizes H in dimension tables revised
21-5-2023	Added Safurex to the material table
10-8-2023	Updated API dimension tables
24-6-2025	Updated dimension tables ASME size "H"

DSS 7006 – 24th of June 2025

Holland – Romania – India – Thailand – Dubai – USA

To our knowledge, the information contained herein is accurate as of the date of this document. However neither Badotherm, nor its affiliates makes any warranty, express or limited, or accepts any liability in connection with this information or its use. This information is for technical skilled persons at their own discretion and risk and does not relate to the use of this product in combination with any other product. The user alone finally determines suitability of any information or material in contemplated use, the manner of use and whether any patents are infringed. This information gives typical properties only. Badotherm reserves the right to make changes to the specifications any materials without prior notice. The latest version of the datasheet can be found on www.badotherm.com.

© 2015 Badotherm, all rights reserved. Trademarks and/or other products referenced herein are either trademarks or registered trademarks of Badotherm.