

LOAD CELLS

RC2 COMPRESSION LOAD CELLS 1 t ... 470 t



- Wide capacity range, 14 sizes between 1 t ... 470 t
- Low profile, robust stainless steel construction
- EU-tested, OIML R60, up to class C5
- Hermetically sealed construction (IP68)
- Ex versions also available
- Guarantee 2 years

Series RC2 compression load cell is ideally suited for verifiable scales as well as for various process weighing applications. It can be used with mounting kits for hopper scales, vehicle scales and silos.

The load cell is robust and designed for use in demanding industrial environments. The body is made of stainless steel and hermetically sealed by laser welding.



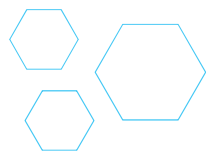

TECHNICAL SPECIFICATIONS AND DIMENSIONS

Nominal load E_{max} t	Limit load L_l t	Break load L_d t	Nom. meas. displacement h_n mm	Load Cell Weight kg
1	1.7	4	0.13	0.6
2.2	4	9	0.12	0.6
4.7	8	19	0.12	0.7
10	17	40	0.17	1.2
15	25	60	0.18	1.3
22	38	90	0.21	1.3
33	58	130	0.25	2.1
47	80	190	0.33	4.3
68	120	270	0.35	4.8
100	170	400	0.45	7.0
150	250	600	0.57	8.6
220	380	900	0.67	22.0
330	580	1200	0.85	29.0
470	700	1500	1.00	50.0

Admissible static side load
 $L_q = 0.5 (E_{max} - 0.8 L_z)$
 but not higher than
 $L_{qmax} = 0.3 E_{max}$;
 E_{max} = nominal load;
 L_z = load in measuring direction

Type RC2	Dimensions mm						
	D	D1	D2	D3	H	H1	H2
1 t	60	53	49	20	43	7,5	-
2,2 t	60	53	49	20	43	7,5	-
4,7 t	60	53	49	20	43	7,5	-
10 t	75	-	75	30	50	6,5	7
15 t	75	-	75	30	50	6,5	7
22 t	75	-	75	30	50	6,5	7
33 t	95	-	95	40	65	10	7
47 t	130	-	130	60	75	14	7
68 t	130	-	130	60	85	14	7
100 t	150	-	150	70	90	16	7
150 t	150	-	150	70	100	16	7
220 t	225	-	225	100	130	24	10
330 t	225	-	225	100	145	24	10
470 t	270	-	270	120	170	28	10

Length of cable:
 5 m RC2 – 1 t...15 t
 5 m RC2 – 150 t...470 t
 15 m RC2 – 22 t...100 t



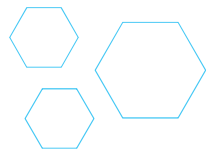

RC2 – 1 t ... 4,7 t

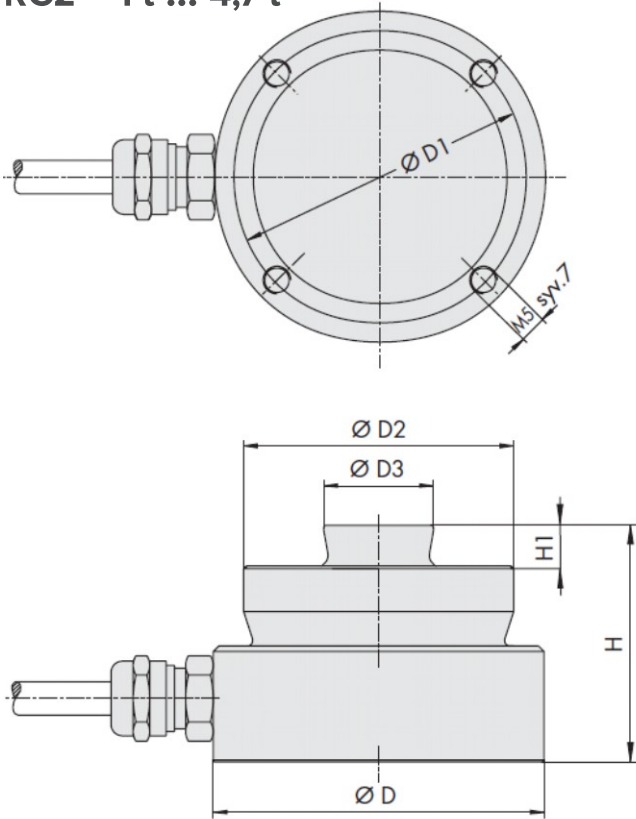

RC2 – 10 t ... 470 t

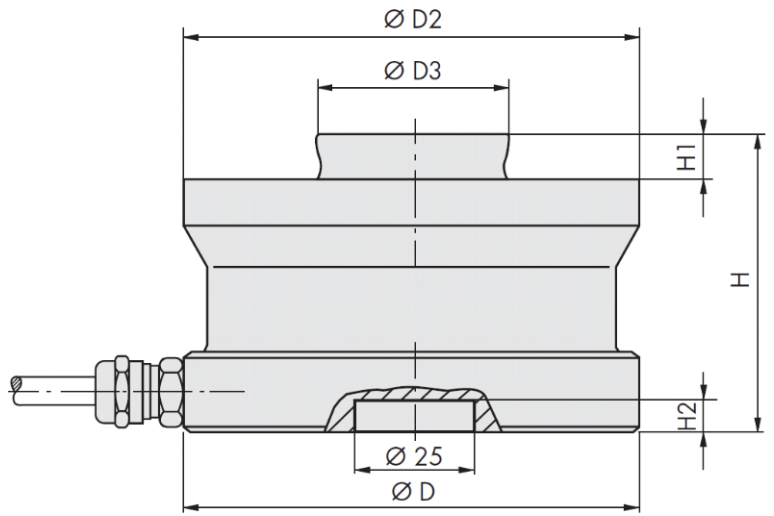

WIRING SCHEMATIC DIAGRAM

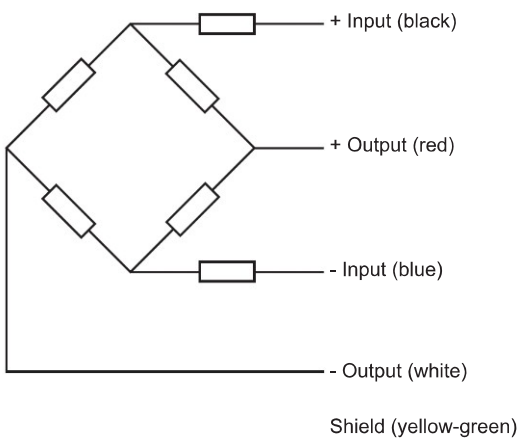

MARKINGS

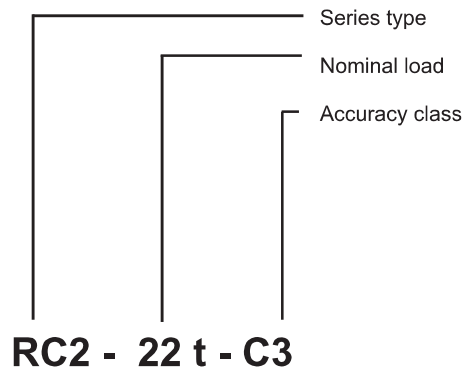

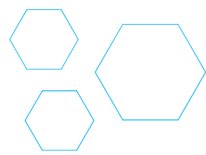

TECHNICAL SPECIFICATIONS

Accuracy class	Symbol	F	C3	C4	C5
Nominal load	E_{max}	10 t - 470 t	1 t – 470 t	1t – 100 t	
Nominal sensitivity	C_n	2,85 mV/V	2,85 mV/V		
Sensitivity tolerance	D_c	±0,3 %	±0,1 %		
Combined error*	F_{comb}	0,1 %	0,02 %	0,015 %	0,01%
Minimum dead load output return	F_{dr}	±0,05 %	±0,016 %	±0,012 %	±0,01 %
Creep 30 min	F_{cr}	±0,06 %	±0,024 %	±0,018 %	±0,014 %
Temperature coefficient of zero point /10 K Nominal temperature range Temperature range	TK_0	±0,1 % ±0,1 %	±0,007 % ±0,02 %	±0,0058 % ±0,02 %	±0,0058 % ±0,02 %
Temperature coefficient of sensitivity /10 K Nominal temperature range Temperature range	TK_c	±0,1 % ±0,1 %	±0,008 % ±0,02 %	±0,007 % ±0,02 %	±0,0062 % ±0,02 %
Minimum verification interval	v_{min}		$E_{max}/20000$	$E_{max}/24000$	
Minimum service range	B_{amin}		15 %	16,7 %	20,8 %
Max utilisation range	B_{amax}		$B_{amax} = E_{max}$		
Input resistance	R_e	4480 Ω ± 50 Ω			
Output resistance	R_a	4010 Ω ± 10 Ω	4010 Ω ± 0,5 Ω		
Zero signal	S_0	±2 %	±1 %		
Maximum voltage supply	$U_{s max}$	100 V	60 V		
Nominal temperature range	B_{tn}	- 10°C ... + 40°C			
Temperature range	B_{tu}	- 40°C ... + 80°C			
Reference temperature	T_r	+ 22°C			
Storage temperature range	B_{ts}	- 50°C ... + 85°C			
Protection class		IP 68			

*Combined error includes non linearity and hysteresis

