

NOTICE
THIS DRAWING IS THE PROPERTY OF QUALITROL COMPANY LLC AND IS LOANED ONLY ON THE CONDITION THAT IT WILL BE USED TO FACILITATE THE PURPOSE FOR WHICH INTENDED AND NOT BE REPRODUCED, COPIED OR OTHERWISE DISPOSED OF, AND IS NOT TO BE USED IN WHOLE OR PART FOR FURNISHING INFORMATION RELATIVE TO THE MAKING OF DRAWINGS, PARTS APPARATUS OR PARTS THEREOF, EXCEPT BY WRITTEN ORDER FROM QUALITROL COMPANY LLC.

MODEL NO. LPRD00-00007203

VIEW SHOWN WITH COVER REMOVED

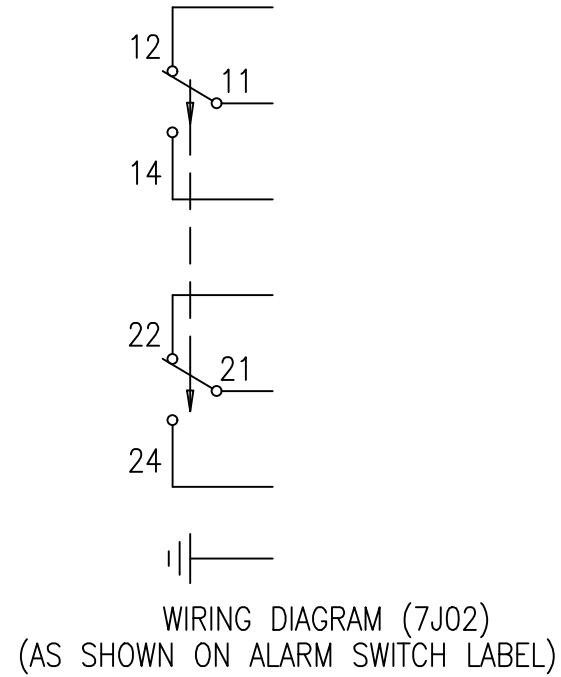

ALERT RED BLEED SCREW WITH O-RING SEAL

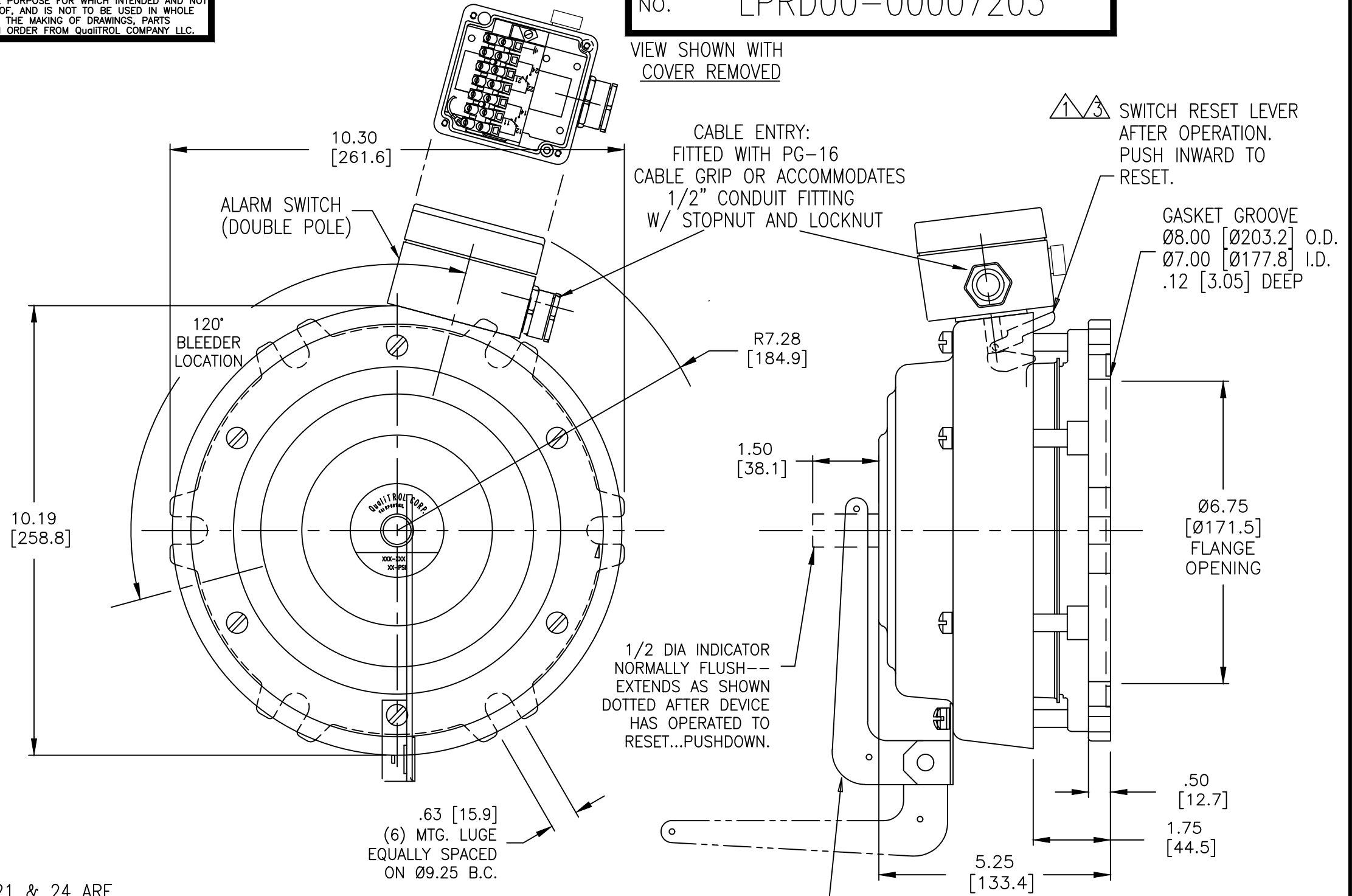
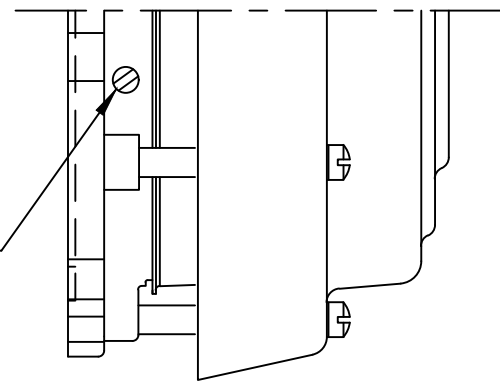

NOTES:

1. 11 AND 12, 21 AND 22 ARE CLOSED. 11 & 14, 21 & 24 ARE OPEN WHEN ALARM SWITCH IS MOUNTED AND ARMED AS SHOWN.
2. WHEN DEVICE OPERATES; 11 & 12, 21 & 22 OPEN, 11 & 14, 21 & 24 CLOSE.
3. WHEN THE SWITCH RESET LEVER IS MANUALLY DEPRESSED; 11 & 12, 21 & 22 WILL CLOSE, 11 & 14, 21 & 24 WILL OPEN.
4. SWITCH RATING: 10 A @ 125/250 VAC
7 A (INDUCTIVE) @ 28 VDC
10 A (RESISTIVE) @ 28 VDC
INSULATION CLASS: 2,000 VAC, 50/60 Hz, 1 MIN.
5. ENCLOSURE CONFORMS TO THE REQUIREMENTS OF IP65

6. FINISH: ASA #70 LT GRAY EPOXY
7. OPERATING PRESSURE: 10±1 PSI (0.69±0.07 BAR)
8. GASKET MATERIAL: NITRILE for MINERAL OIL
9. INDICATOR COLOR: YELLOW

10. SEMAPHORE COLOR/MATERIAL: YELLOW/POLYCARBONATE
11. GASKET RETENTION TYPE: EPOXY POTTED
12. STANDARD OUTDOOR USE
13. MOUNTING GASKET(S): (1) NITRILE SUPPLIED WITH UNIT

—	11-16-2021	FEW DIMENSIONS ARE UPDATED	41571
—	3/22/17	WAS ENC-023-3 WITH VNT-013-1	36256
—	1-5-09	DRAWING CREATED	—
LET	DATE	ALTERATION	C.N.

QUALITROL

DIMENSIONS AND TOLERANCES IN ACCORDANCE WITH ASME Y14.5M-1994

PH. (585) 586-1515
FAX (585) 377-0220

1385 FAIRPORT ROAD
FAIRPORT, NY 14450

FORM 0-473 REV. F 04/06/06

TITLE: PRESSURE RELIEF DEVICE w/
DIRECT (2 POLE) SWITCH WIRING

MODEL NO. LPRD00-00007203