

Think Controls

# FOTEK

## Solid State Module

- |               |                |
|---------------|----------------|
| § SSR series  | § SSR-F series |
| § HPR series  | § SSR-K series |
| § ESR series  | § SSR-R series |
| § TSR series  | § SSR-Y series |
| § EZR series  | § SSR-P series |
| § ESR+ series | § SSR-M series |

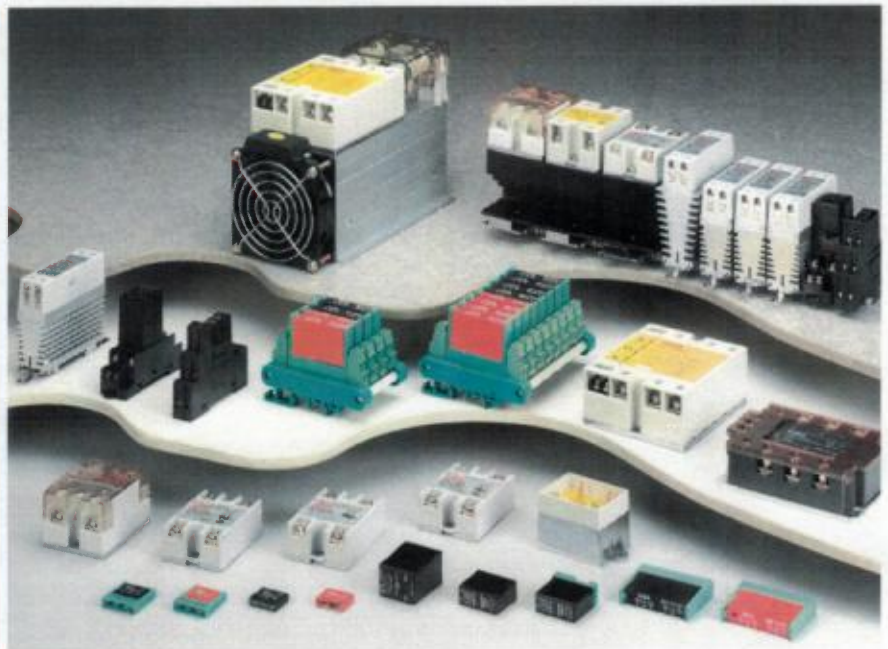

陽明電機股份有限公司  
FOTEK CONTROLS CO., LTD.

### § SSR / SCR ..... P.5 ~ P.9

- ▶ Input: 4~32Vdc / 80~250Vac / 4~20mA / VR
- ▶ Output: 24~380Vac / 90~480Vac / 5~60Vdc
- ▶ Rated current: 5A / 10A / 25A / 40A / 50A / 75A
- ▶ Outline: 45mm \* 60mm \* 22.5mm

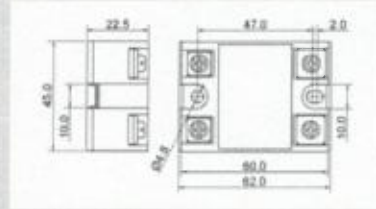

### § EZR ..... P.10

- ▶ Input: 4~32Vdc / 80~250Vac
- ▶ Output: 24~380Vac / 90~480Vac
- ▶ Rated current: 10A / 25A / 40A
- ▶ Outline: 40.5 mm \* 66.0 mm \* 37.0 mm

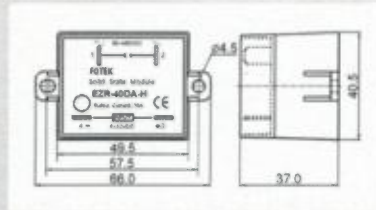

### § HPR ..... P.11 ~ P.12

- ▶ Input: 4~32Vdc / 20 ~ 265 Vac/dc
- ▶ Output: 24~380Vac / 24~550Vac
- ▶ Rated current: 60 / 80A / 100A
- ▶ Outline: 45 mm \* 62 mm \* 32 mm

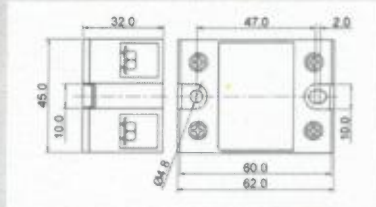

### § SSR-F / SCR-F ..... P.13 ~ P.14

- ▶ Input: 4~32Vdc / 80~250Vac / 4~20mA
- ▶ Output: 24~380Vac / 90~480Vac
- ▶ Rated current: 10A / 25A / 40A
- ▶ Outline: 45 mm \* 62 mm \* 35 mm

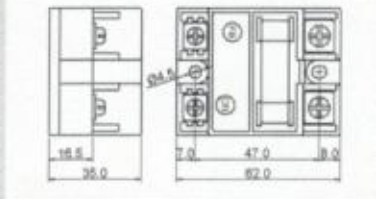

### § SSR-Y ..... P.15

- ▶ Input: 4~32Vdc
- ▶ Output: 24~380Vac / 5~60Vdc
- ▶ Rated current: 5A
- ▶ Outline: 21.5 mm \* 28.0 mm \* 35.2 mm

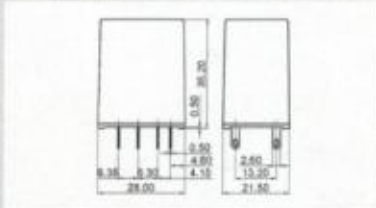

### § SSR-R ..... P.16

- ▶ Input: 4~32Vdc
- ▶ Output: 24~380Vac / 5~60Vdc
- ▶ Rated current: 2A / 5A
- ▶ Outline: 12.6 mm \* 29.6 mm \* 24.8 mm

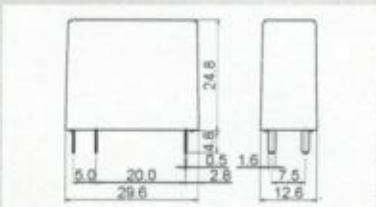

**§ SSR-K / SCR-K** ..... P.17 ~ P.20

- ▶ Input: 4~32Vdc / 20~265Vac/dc / 4~20mA
- ▶ Output: 24~380Vac / 90~550Vac / 5~60Vdc / 5~150Vdc
- ▶ Rated current: 5A / 10A / 20A / 30A / 40A
- ▶ Outline: 25.0mm \* 77.0mm \* 74.6mm/  
36.0mm \* 77.0mm \* 74.6mm(40A)

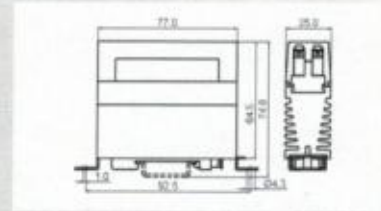

**§ TSR** ..... P.21 ~ P.22

- ▶ Input: 4~32Vdc / 80 ~ 250 Vac
- ▶ Output: 24~380Vac / 90~480Vac
- ▶ Rated current: 25A / 40 / 50A / 75A
- ▶ Outline: 100.0mm \* 80.0mm \* 30.0mm

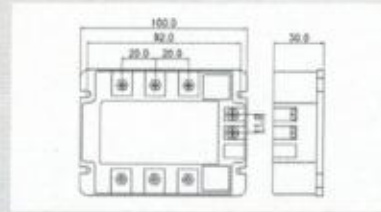

**§ ESR** ..... P.23 ~ P.24

- ▶ Input: 4~32Vdc / 20 ~ 265 Vac/dc
- ▶ Output: 24~380Vac / 90~480Vac
- ▶ Rated current: 40A / 60 / 80A / 100A
- ▶ Outline: 80.0mm \* 100.0 mm \* 40.0 mm

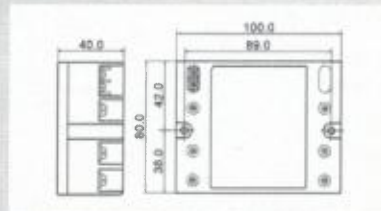

**§ ESR +** ..... P.25 ~ P.26

- ▶ Input: 4~32Vdc / 20 ~ 265 Vac/dc
- ▶ Output: 24~380Vac / 90~480Vac
- ▶ Rated current: 40A / 60 / 80A / 100A
- ▶ Outline: 96.0mm \* 192.0 mm \* 129.0 mm

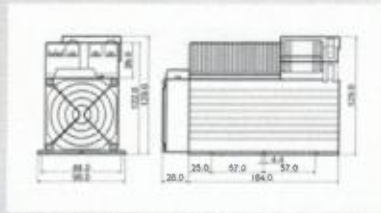

**§ SSR-P** ..... P.27

- ▶ Input: 4~32Vdc
- ▶ Output: 24~380Vac / 5~60Vdc
- ▶ Rated current: 3A / 5A
- ▶ Outline: 10mm \* 43mm \* 26mm

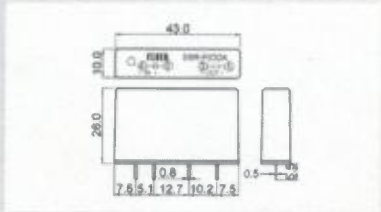

**§ SSR-M** ..... P.27

- ▶ Input: 4~32Vdc
- ▶ Output: 24~380Vac / 5~60Vdc
- ▶ Rated current: 1A / 5A
- ▶ Outline: 5mm \* 20mm \* 17mm

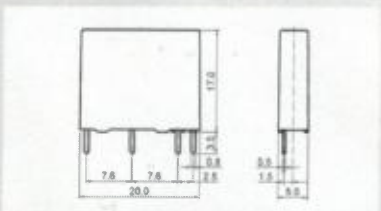

- \* High Dielectric strength over 4KV
- \* High Isolation strength over 100MΩ/500VDC
- \* With over heat protection Circuit ( 120°C )
- \* High surge current sustenance
- \* High surge voltage sustenance
- \* Conformity with EN60947-4-3 and EN60950

- \* 高電介強度超過4KV
- \* 高絕緣強度超過100MΩ/500VDC
- \* 附過熱保護回路可防止過熱破壞
- \* 耐瞬間電流超過額定電流10倍以上
- \* 附雙重突波吸收回路有效防止突波破壞
- \* 符合EN60947-4-3 and EN60950標準

### Guiding of model / 型號索引

#### Terminal type / 端子式

Ex: **SSR - 40 D A - H - R**  
           1      2  3  4  5  6

##### 1> Product / 產品

- 「SSR」 = Single phase solid state module
- 「HPR」 = High power solid state module
- 「TSR」 = Three phases solid state module
- 「ESR」 = Three phases High power solid state module
- 「EZR」 = Plug type solid state module

##### 2> Output current / 輸出電流

- 「10」 = 10A   「25」 = 25A   「40」 = 40A
- 「50」 = 50A   「60」 = 60A   「80」 = 80A

##### 3> Input method / 輸入方式

- 「D」 = 4 ~ 32VDC
- 「A」 = 80 ~ 250VAC
- 「L」 = 4 ~ 20mA
- 「V」 = Variable resistor

##### 4> Output voltage / 輸出電壓

- 「A」 = AC voltage
- 「D」 = DC voltage

##### 5> Output voltage range / 輸出電壓範圍

- 「H」 = High voltage type
- 「Non」 = Standard type

##### 6> Control method / 控制方式

- 「R」 = Random control
- 「Non」 = Zero cross control

#### PCB or Fuse type / 基板或保險絲型

Ex: **SSR - P 03 D A - H**  
           1      2  3  4  5  6

##### 1> Product / 產品

- 「SSR」 = Single phase solid state module
- 「SCR」 = Single phase linear solid state module

##### 2> Mounting method or Others

- 「P」 = PCB type
- 「M」 = Mini PCB type
- 「Y」 = Relay type
- 「R」 = Relay type
- 「K」 = Heat-sink type
- 「F」 = Fuse type

##### 3> Output current / 輸出電流

- 「03」 = 3A   「10」 = 10A
- 「25」 = 25A   「40」 = 40A

##### 4> Input method / 輸入方式

- 「D」 = 4 ~ 32VDC
- 「A」 = 80 ~ 250VAC
- 「L」 = 4 ~ 20mA

##### 5> Output voltage / 輸出電壓

- 「A」 = AC voltage
- 「D」 = DC voltage

##### 6> Output voltage range / 輸出電壓範圍

- 「H」 = High voltage type
- 「Non」 = Standard type

Control method / 控制方式

**Zero cross trigger method**

Output will be turned ON or Turned OFF only on the Zero point of sine wave, that may avoid to occur the EMI or RFI. Specially suited to control the resistive, capacitive and non-saturated inductive load.

輸出只有在正弦波的零點上有輸入訊號時才會打開或關閉，以避免產生突波或EMI / RFI。特別適用於控制阻抗性或電容性或不飽和感抗性等負載。

Line  
Input  
Output

**Variable resistance control method ( Trimmer control )**

Power output is controlled by the Trigger angle of the Triac that is controlled with variable resistor.

( 250KΩ/110VAC, 500KΩ/220VAC, 1MΩ/220VAC )  
以可變電阻控制Triac的觸發角來控制輸出功率。  
( 250KΩ/110VAC, 500KΩ/220VAC, 1MΩ/380VAC )

Line  
0%  
50%  
100%

Application hints / 應用說明

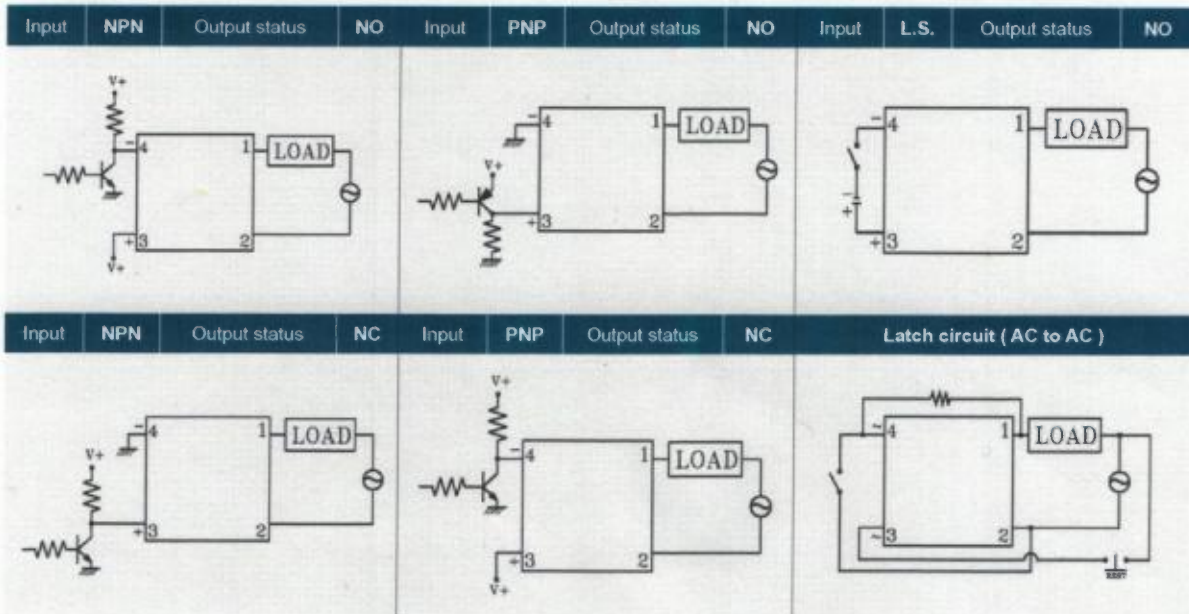

### ■ Specification [ Rated current corresponding to Resistive load ]

Type	型式	Standard type / 標準型				
Model	型號	SSR - 10DA	SSR - 26DA	SSR - 40DA	SSR - 60DA	SSR - 76DA
Rated current	額定電流	10A max.	25A max.	40A max.	50A max.	75A max.
I <sup>2</sup> t for fuse	熔斷電流	144A <sup>2</sup> S	259A <sup>2</sup> S	664A <sup>2</sup> S	518A <sup>2</sup> S	1328A <sup>2</sup> S
Surge current	耐突波電流	135A	275A	410A	550A	820A
Peak voltage	耐突波電壓	1200VAC min.				
Output voltage	輸出電壓	24 ~ 380VAC				

Type	型式	High voltage type / 高壓型				
Model	型號	SSR - 10DA-H	SSR - 26DA-H	SSR - 40DA-H	SSR - 60DA-H	SSR - 76DA-H
Rated current	額定電流	10A max.	25A max.	40A max.	50A max.	75A max.
I <sup>2</sup> t for fuse	熔斷電流	144A <sup>2</sup> S	259A <sup>2</sup> S	664A <sup>2</sup> S	518A <sup>2</sup> S	1328A <sup>2</sup> S
Surge current	耐突波電流	135A	275A	410A	550A	820A
Peak voltage	耐突波電壓	1200VAC min.				
Output voltage	輸出電壓	90 ~ 480VAC				

General specification / 共同規格		
Input voltage	輸入電壓	4 ~ 32 VDC
Turn off voltage	關閉電壓	< 3.5 VDC
Trigger current	觸發電流	12.0mA max.
Control method	控制方式	Zero cross
Leakage current	洩漏電流	5 mA max.
Response time	反應時間	8.3 ms (60Hz)
Input immunity	輸入耐突波	2 KV ( EN61000-4-4 )
Isolation strength	電介強度	4 KVrms ( EN60950/VDE0805 )
Insulation strength	絕緣強度	100MΩ / 500VDC ( EN60950/VDE0805 )
Housing material	外殼材質	防火ABS ( UL: 94V0 )
Circumstance	工作環境	-40°C ~ +80°C ; 35 ~ 85%RH

### ■ Outline dimension / 外形尺寸



### ■ Connection / 接線圖

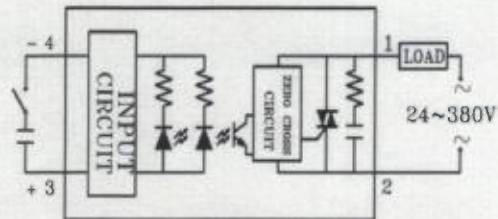

## ■ Specification [ Rated current corresponding to Resistive load ]

Type	型式	Standard type / 標準型				
Model	型號	SSR - 10AA	SSR - 25AA	SSR - 40AA	SSR - 50AA	SSR - 75AA
Rated current	額定電流	10A max.	25A max.	40A max.	50A max.	75A max.
I <sup>2</sup> t for fuse	熔斷電流	144A <sup>2</sup> S	259A <sup>2</sup> S	664A <sup>2</sup> S	518A <sup>2</sup> S	1328A <sup>2</sup> S
Surge current	耐突波電流	135A	275A	410A	550A	820A
Peak voltage	耐突波電壓	1200VAC min.				
Output voltage	輸出電壓	24 ~ 380VAC				

Type	型式	High voltage type / 高壓型				
Model	型號	SSR - 10AA-H	SSR - 25AA-H	SSR - 40AA-H	SSR - 50AA-H	SSR - 75AA-H
Rated current	額定電流	10A max.	25A max.	40A max.	50A max.	75A max.
I <sup>2</sup> t for fuse	熔斷電流	144A <sup>2</sup> S	259A <sup>2</sup> S	664A <sup>2</sup> S	518A <sup>2</sup> S	1328A <sup>2</sup> S
Surge current	耐突波電流	135A	275A	410A	550A	820A
Peak voltage	耐突波電壓	1200VAC min.				
Output voltage	輸出電壓	90 ~ 480VAC				

General specification / 共同規格		
Input voltage	輸入電壓	80 ~ 250 VAC 50/60Hz
Turn off voltage	關閉電壓	< 35 VAC
Trigger current	觸發電流	1.0VA max.
Control method	控制方式	Zero cross switching
Leakage current	洩漏電流	5 mA max.
Response time	反應時間	8.3 ms (60Hz) max.
Input immunity	輸入耐突波	2 KV (EN61000-4-4)
Isolation strength	電介強度	4 KVrms (EN60950/VDE0805)
Insulation strength	絕緣強度	100MΩ / 500VDC (EN60950/VDE0805)
Housing material	外殼材質	防火ABS (UL: 94V0)
Circumstance	工作環境	-40°C ~ +80°C ; 35 ~ 85%RH

## ■ Outline dimension / 外形尺寸



## ■ Connection / 接線圖

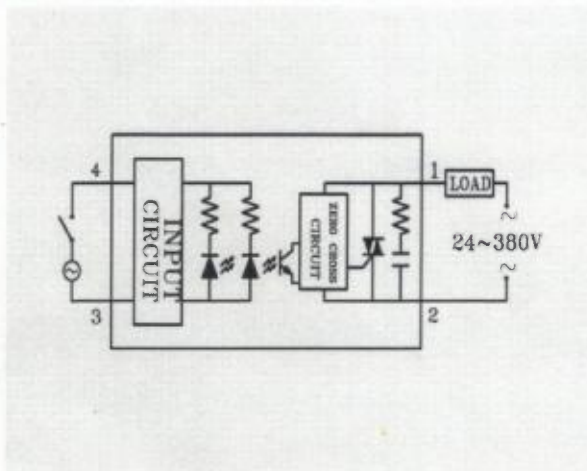

■ Specification [ Rated current corresponding to Resistive load ]

Type	型式	Standard type / 標準型				
Model	型號	SCR - 10LA	SCR - 25LA	SCR - 40LA	SCR - 50LA	SCR - 75LA
Rated current	額定電流	10A max.	25A max.	40A max.	50A max.	75A max.
I <sup>2</sup> t for fuse	熔斷電流	144A <sup>2</sup> S	259A <sup>2</sup> S	664A <sup>2</sup> S	518A <sup>2</sup> S	1328A <sup>2</sup> S
Surge current	耐突波電流	135A	275A	410A	550A	820A
Peak voltage	耐突波電壓	1200VAC min.				
Output voltage	輸出電壓	90 ~ 250VAC				

Type	型式	High voltage type / 高壓型				
Model	型號	SCR - 10LA-H	SCR - 25LA-H	SCR - 40LA-H	SCR - 50LA-H	SCR - 75LA-H
Rated current	額定電流	10A max.	25A max.	40A max.	50A max.	75A max.
I <sup>2</sup> t for fuse	熔斷電流	144A <sup>2</sup> S	259A <sup>2</sup> S	664A <sup>2</sup> S	518A <sup>2</sup> S	1328A <sup>2</sup> S
Surge current	耐突波電流	135A	275A	410A	550A	820A
Peak voltage	耐突波電壓	1200VAC min.				
Output voltage	輸出電壓	250 ~ 480VAC				

General specification / 共同規格		
Input method	輸入方式	4 ~ 20 mA
Input resistance	輸入阻抗	Approx. 1.2KΩ
Control method	控制方式	Phase control
Leakage current	洩漏電流	0.5% of full load max.
Response time	反應時間	1.0ms max.
Input immunity	輸入耐突波	4 KVrms ( EN60950/VDE0805 )
Isolation strength	電介強度	100MΩ / 500VDC ( EN60950/VDE0805 )
Insulation strength	絕緣強度	100MΩ / 500VDC ( EN60950/VDE0805 )
Housing material	外殼材質	防火ABS ( UL: 94V0 )
Circumstance	工作環境	-40°C ~ +80°C ; 35 ~ 85%RH

■ Outline dimension / 外形尺寸

■ Connection / 接線圖

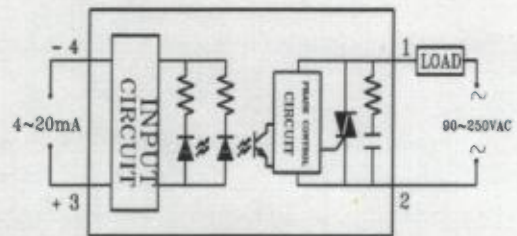

# Single phase Adjustable Solid State Module

SSR-VA series

CE, RoHS, UL

## ■ Specification [ Rated current corresponding to Resistive load ]

Type	型式	Standard type / 標準型				
Model	型號	SSR - 10VA	SSR - 25VA	SSR - 40VA	SSR - 60VA	SSR - 75VA
Rated current	額定電流	10A max.	25A max.	40A max.	50A max.	75A max.
I <sup>2</sup> t for fuse	熔斷電流	144A <sup>2</sup> S	259A <sup>2</sup> S	664A <sup>2</sup> S	518A <sup>2</sup> S	1328A <sup>2</sup> S
Surge current	耐突波電流	135A	275A	410A	550A	820A
Peak voltage	耐突波電壓	1200VAC min.				
Output voltage	輸出電壓	24 ~ 380VAC				

Type	型式	High voltage type / 高壓型				
Model	型號	SSR-10VA - H	SSR-25VA - H	SSR-40VA - H	SSR - 60VA-H	SSR - 75VA-H
Rated current	額定電流	10A max.	25A max.	40A max.	50A max.	75A max.
I <sup>2</sup> t for fuse	熔斷電流	144A <sup>2</sup> S	259A <sup>2</sup> S	664A <sup>2</sup> S	518A <sup>2</sup> S	1328A <sup>2</sup> S
Surge current	耐突波電流	135A	275A	410A	550A	820A
Peak voltage	耐突波電壓	1200VAC min.				
Output voltage	輸出電壓	90 ~ 480VAC				

General specification / 共同規格		
Input voltage	輸入電壓	Variable resistor
Input resistance	輸入阻值	250KΩ/110VAC ; 500KΩ/220VAC ; 1MΩ/380VAC ; 1MΩ/480VAC
Wattage of VR	VR功率	1/4 W min.
Control method	控制方式	Phase control
Leakage current	洩漏電流	5.0 mA max.
Response time	反應時間	1.0ms max.
Input immunity	輸入耐突波	2 KV ( EN61000-4-4 )
Isolation strength	電介強度	4 KVrms ( EN60950/VDE0805 )
Insulation strength	絕緣強度	100MΩ / 500VDC ( EN60950/VDE0805 )
Circumstance	工作環境	-40°C ~ +80°C ; 35 ~ 85%RH

## ■ Outline dimension / 外形尺寸



## ■ Connection / 接線圖

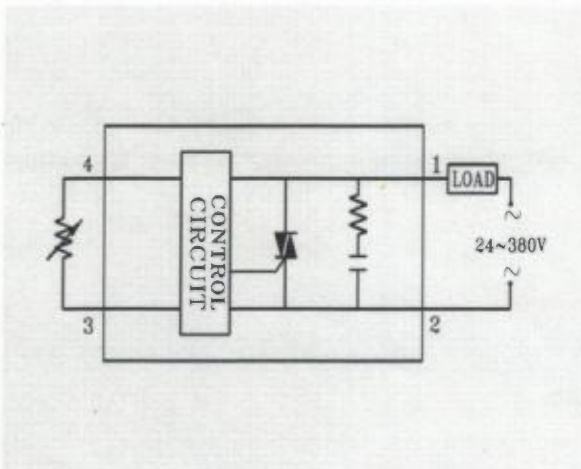

### ■ Specification [ Rated current corresponding to Resistive load ]

Type	型式	Standard type / 標準型				
Model	型號	SSR - 06DD	SSR - 10DD	SSR-26DD	SSR-60DD	SSR-75DD
Rated current	額定電流	5A max.	10A max.	25A max	50A max	75A max
Surge current	耐突波電流	15A max.	30A max.	50A max.	150A max.	225A max.
Peak voltage	耐突波電壓	300VDC	300VDC	600VDC	600VDC	600VDC
Response time	反應時間	1.0 ms			1.0 ms	
Output voltage	輸出電壓	5 ~ 60VDC			5 ~ 120VDC	

Type	型式	High voltage type / 高壓型		
Model	型號	SSR-26DD-H	SSR-60DD-H	SSR-75DD-H
Rated current	額定電流	25A max	50A max	75A max
Surge current	耐突波電流	50A max.	150A max.	225A max.
Peak voltage	耐突波電壓	600VDC	600VDC	600VDC
Response time	反應時間	1.0 ms		
Output voltage	輸出電壓	5 ~ 300VDC		

General specification / 共同規格		
Input voltage	輸入電壓	4 ~ 32 VDC
Turn off voltage	關閉電壓	< 3.0 VDC
Trigger current	觸發電流	12mA max.
Control method	控制方式	Random
Leakage current	洩漏電流	1.0 mA
Response time	反應時間	1.0 ms
Input immunity	輸入耐突波	2 KV ( EN61000-4-4 )
Isolation strength	電介強度	4 KVrms ( EN60950/VDE0805 )
Insulation strength	絕緣強度	100MΩ / 500VDC ( EN60950/VDE0805 )
Circumstance	工作環境	-40°C ~ +80°C ; 35 ~ 85%RH

### ■ Outline dimension / 外形尺寸



### ■ Connection / 接線圖

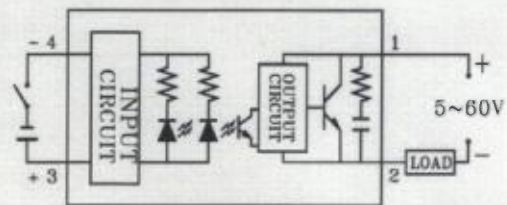

**Single phase Plug type Solid State Module**

EZR series

CE, RoHS, UL

**Specification [ Rated current corresponding to Resistive load ]**

Type	型式	DC to AC	
Model	型號	<b>EZR-40DA</b>	<b>EZR-40DA-H</b>
Rated current	額定電流	16A max.	16A max.
Output voltage	輸出電壓	24 ~ 380VAC	90 ~ 480 VAC
Input voltage	輸入電壓	4 ~ 32 VDC	
Trigger current	觸發電流	15 mA max.	
Turn off voltage	關閉電壓	< 3.0 VDC	

Type	型式	AC to AC	
Model	型號	<b>EZR-40AA</b>	<b>EZR-40AA-H</b>
Rated current	額定電流	16A max.	16A max.
Output voltage	輸出電壓	24 ~ 380VAC	90 ~ 480 VAC
Input voltage	輸入電壓	90 ~ 250 VAC	
Trigger current	觸發電流	1 VA max.	
Turn off voltage	關閉電壓	< 35VAC	

General specification / 共同規格		
Surge current	耐突波電流	410A / one cycle
Peak voltage	耐突波電壓	1200VAC
Control method	控制方式	Zero cross switching
Leakage current	洩漏電流	5 mA max.
Voltage drop	輸出壓降	1.6V max.
Response time	反應時間	8.3 ms ( 60Hz )
Over heat protection	過熱保護	Turn off output over 120°C ; Reset below 110°C
Input immunity	輸入耐突波	2 KV ( EN61000-4-4 )
Isolation strength	電介強度	4 KVrms ( EN60950/VDE0805 )
Insulation strength	絕緣強度	100MΩ / 500VDC ( EN60950/VDE0805 )
Circumstance	工作環境	-40°C ~ +80°C ; 35 ~ 85%RH

**Outline dimension / 外形尺寸**



**Connection / 接線圖**

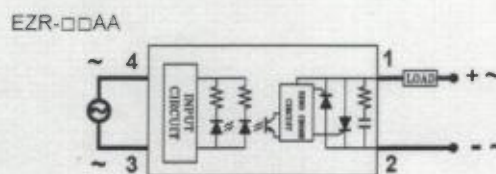
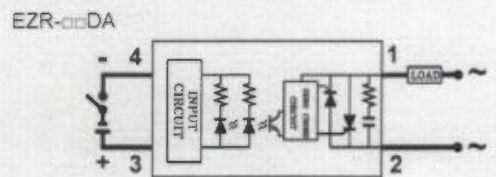

### ■ Specification [ Rated current corresponding to Resistive load ]

Type	型式	Standard type / 標準型		
Model	型號	HPR-60DA	HPR-80DA	HPR-100DA
Rated current	額定電流	60A max.	80A max.	100A max.
I <sup>2</sup> t for fuse	熔斷電流	1800A <sup>2</sup> s	3200A <sup>2</sup> s	7200A <sup>2</sup> s
Surge current	耐突波電流	850A	1200A	1750A
Peak voltage	耐突波電壓	1200VAC	1200VAC	1200VAC
Output voltage	輸出電壓	24 ~ 380VAC		

Type	型式	High voltage type / 高壓型		
Model	型號	HPR-60DA-H	HPR-80DA-H	HPR-100DA-H
Rated current	額定電流	60A max.	80A max.	100A max.
I <sup>2</sup> t for fuse	熔斷電流	1800A <sup>2</sup> s	3200A <sup>2</sup> s	7200A <sup>2</sup> s
Surge current	耐突波電流	850A	1200A	1750A
Peak voltage	耐突波電壓	1200VAC	1200VAC	1200VAC
Output voltage	輸出電壓	24 ~ 550VAC		

General specification / 共同規格		
Input voltage	輸入電壓	4 ~ 32 VDC
Turn off voltage	關閉電壓	< 3.0 VDC
Trigger current	觸發電流	12mA max.
Control method	控制方式	Zero cross switching
Leakage current	洩漏電流	5 mA max.
Response time	反應時間	8.3 ms ( 60Hz )
Over heat protection	過熱保護	Turn off output over 120°C ; Reset below 110°C
Input immunity	輸入耐突波	2 KV ( EN61000-4-4 )
Isolation strength	電介強度	4 KVrms ( EN60950/VDE0805 )
Insulation strength	絕緣強度	100MΩ / 500VDC ( EN60950/VDE0805 )
Circumstance	工作環境	-40°C ~ +80°C ; 35 ~ 85%RH

### ■ Outline dimension / 外形尺寸

HPR-xxDA / HPR-xxDA-H

HPR-xxDA+  
Heat sink ( HS-ESR-60 ) + Fan

### ■ Connection / 接線圖

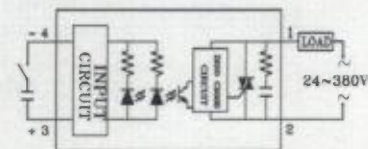

# Single Phase High Power type AC to AC Solid State Module

HPR series

CE, RoHS

## ■ Specification [ Rated current corresponding to Resistive load ]

Type	型式	Standard type / 標準型		
Model	型號	HPR-60AA	HPR-80AA	HPR-100AA
Rated current	額定電流	60A max.	80A max.	100A max.
I <sup>2</sup> t for fuse	熔斷電流	1800A <sup>2</sup> s	3200A <sup>2</sup> s	7200A <sup>2</sup> s
Protection fuse	保險絲	63A/600VAC	80A/600VAC	100A/600VAC
Surge current	耐突波電流	850A	1200A	1750A
Peak voltage	耐突波電壓	1200VAC	1200VAC	1200VAC
Output voltage	輸出電壓	24 ~ 380VAC		

Type	型式	High voltage type / 高壓型		
Model	型號	HPR-60AA-H	HPR-80AA-H	HPR-100AA-H
Rated current	額定電流	60A max.	80A max.	100A max.
I <sup>2</sup> t for fuse	熔斷電流	1800A <sup>2</sup> s	3200A <sup>2</sup> s	7200A <sup>2</sup> s
Protection fuse	保險絲	63A/600VAC	80A/600VAC	100A/600VAC
Surge current	耐突波電流	850A	1200A	1750A
Peak voltage	耐突波電壓	1200VAC	1200VAC	1200VAC
Output voltage	輸出電壓	24 ~ 550VAC		

General specification / 共同規格		
Input voltage	輸入電壓	20 ~ 265 VAC/DC
Turn off voltage	關閉電壓	< 12 VAC/DC
Trigger current	觸發電流	3VA max.
Control method	控制方式	Zero cross switching
Leakage current	洩漏電流	5 mA max.
Response time	反應時間	8.3 ms ( 60Hz )
Over heat protection	過熱保護	Turn off output over 120°C ; Reset below 110°C
Input immunity	輸入耐突波	2 KV ( EN61000-4-4 )
Isolation strength	電介強度	4 KVrms ( EN60950/VDE0805 )
Insulation strength	絕緣強度	100MΩ / 500VDC ( EN60950/VDE0805 )
Circumstance	工作環境	-40°C ~ +80°C ; 35 ~ 85%RH

## ■ Outline dimension / 外形尺寸

HPR-xxAA / HPR-xxAA-H

HPR-xxAA+  
Heat sink ( HS-ESR-60 ) + Fan

## ■ Connection / 接線圖

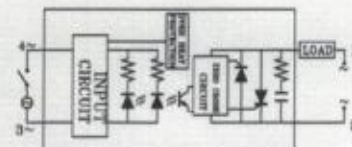

### ■ Specification [ Rated current corresponding to Resistive load ]

Type	型式	Standard type / 標準型			High voltage type / 高壓型		
Model	型號	SSR-F-10DA	SSR-F-26DA	SSR-F-40DA	SSR-F-10DA-H	SSR-F-26DA-H	SSR-F-40DA-H
Rated current	額定電流	5A	12A	20A	5A	12A	20A
Fuse current	保險絲電流	6A	16A	25A	6A	16A	25A
Surge current	耐突波電流	135A	275A	410A	135A	275A	410A
Output voltage	輸出電壓	24 ~ 380VAC			90 ~ 480VAC		
Peak voltage	耐突波電壓	1200VAC min.					

Type	型式	Standard type / 標準型			High voltage type / 高壓型		
Model	型號	SCR-F-10LA	SCR-F-26LA	SCR-F-40LA	SCR-F-10LA-H	SCR-F-26LA-H	SCR-F-40LA-H
Rated current	額定電流	5A	12A	20A	5A	12A	20A
Fuse current	保險絲電流	6A	16A	25A	6A <td 16A	25A	
Surge current	耐突波電流	135A	275A	410A	135A	275A	410A
Output voltage	輸出電壓	90 ~ 380VAC			180 ~ 480VAC		
Peak voltage	耐突波電壓	1200VAC min					

General data / 共同規格		DC to AC	Linear control
Input voltage	輸入電壓	4 ~ 32 VDC	4 ~ 20 mA
Turn off voltage	關閉電壓	< 3.5 VDC	Approx. 1.2KΩ
Trigger current	觸發電流	12.0mA max.	
Control method	控制方式	Zero cross	Phase control
Leakage current	洩漏電流	5 mA max.	0.5% of full load max.
Response time	反應時間	8.3 ms (60Hz)	1.0ms max.
Input immunity	輸入耐突波	2 KV ( EN61000-4-4 )	
Isolation strength	電介強度	4 KVrms ( EN60950/VDE0805 )	
Insulation strength	絕緣強度	100MΩ / 500VDC ( EN60950/VDE0805 )	
Housing material	外殼材質	防火ABS ( UL: 94V0 )	
Circumstance	工作環境	-40°C ~ +80°C ; 35 ~ 85%RH	

### ■ Outline dimension / 外形尺寸

SSR - F - xx

### ■ Connection / 接線圖

DC TO AC

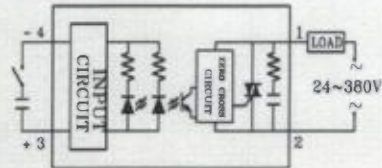

AC TO AC

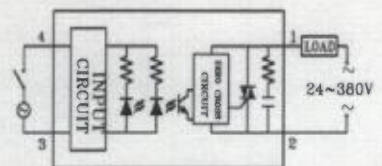

# Single phase Fuse type AC to AC Solid State Module

SSR-F-AA series

CE, RoHS, UL

## ■ Specification [ Rated current corresponding to Resistive load ]

Type	型式	Standard type / 標準型		
Model	型號	SSR - F - 10AA	SSR - F - 25AA	SSR - F - 40AA
Rated current	額定電流	10A max.	25A max.	40A max
Fuse current	保險絲電流	6A	16A	25A
Surge current	耐突波電流	135A	275A	410A
Peak voltage	耐突波電壓	1200VAC min.		
Output voltage	輸出電壓	24 ~ 380VAC		

Type	型式	High voltage type / 高壓型		
Model	型號	SSR - F - 10AA -H	SSR - F - 25AA-H	SSR - F - 40AA-H
Rated current	額定電流	10A max.	25A max.	40A max
Fuse current	保險絲電流	6A	16A	25A
Surge current	耐突波電流	135A	275A	410A
Peak voltage	耐突波電壓	1200VAC min.		
Output voltage	輸出電壓	90 ~ 480VAC		

		General specification / 共同規格	
Input voltage	輸入電壓	80 ~ 250 VAC 50/60Hz	
Turn off voltage	關閉電壓	< 35 VAC	
Trigger current	觸發電流	1.0VA max.	
Control method	控制方式	Zero cross switching	
Leakage current	洩漏電流	5 mA max.	
Response time	反應時間	8.3 ms (60Hz) max.	
Input immunity	輸入耐突波	2 KV ( EN61000-4-4 )	
Isolation strength	電介強度	4 KVrms ( EN60950/VDE0805 )	
Insulation strength	絕緣強度	100MΩ / 500VDC ( EN60950/VDE0805 )	
Housing material	外殼材質	防火ABS ( UL: 94V0 )	
Circumstance	工作環境	-40°C ~ +80°C ; 35 ~ 85%RH	

## ■ How to renew the fuse / 如何更換保險絲

The fuse may be broken when the 「FB」 pilot LED is turn ON, please renew the use.  
當「FB」指示 亮著，表示「保險絲」可能已燒毀，請更換「保險絲」。

Step 1	Step 2	Step 3	Step 4	Step 5
Shut down power supply 關閉電源	Take away cover 打開保護蓋	Pick up fuse 取出燒毀保險絲	Renew fuse 更換新保險絲 【請確認保險絲兩端 是否確實安裝】	Put on cover 裝回保護蓋

**Note** : 「Power supply system」 must be shut down before renewing the fuse.

### ■ Specification [ Rated current corresponding to Resistive load ]

Type	型式	DC to AC type / 直流對交流型
Model	型號	SSR - Y05DA
Rated current	額定電流	5A max.
I <sup>2</sup> t for fuse	熔斷電流	144A <sup>2</sup> S
Surge current	耐突波電流	135A
Peak voltage	耐突波電壓	1200VAC min.
Output voltage	輸出電壓	24~380VAC 50/60Hz

Type	型式	DC to DC type
Model	型號	SSR - Y05DD
Rated current	額定電流	5A max.
Surge current	耐突波電流	15A min.
Peak voltage	耐突波電壓	120VDC min.
Output voltage	輸出電壓	5~60VDC

General specification / 共同規格			
Type	型式	DC to AC type	DC to DC type
Input voltage	輸入電壓	4 ~ 32 VDC	4 ~ 32 VDC
Turn off voltage	關閉電壓	< 3.0 VDC	< 3.0 VDC
Trigger current	觸發電流	12mA max.	12mA max.
Control method	控制方式	Zero cross switching	Random
Leakage current	洩漏電流	5 mA max.	1.0 mA max.
Response time	反應時間	8.3 ms ( 60Hz ) max.	1.0 ms
Application temperature	使用溫度	Ta < 50°C	
Input immunity	輸入耐突波	2 KV ( EN61000-4-4 )	
Isolation strength	電介強度	4 KVrms ( EN60950/VDE0805 )	
Insulation strength	絕緣強度	100MΩ / 500VDC ( EN60950/VDE0805 )	
Circumstance	工作環境	-40°C ~ +80°C : 35 ~ 85%RH	

### ■ Outline dimension / 外形尺寸



### ■ Connection / 接線圖

DC TO AC

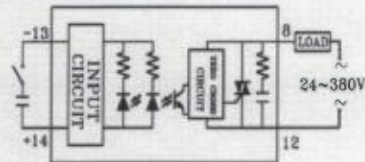

DC TO DC

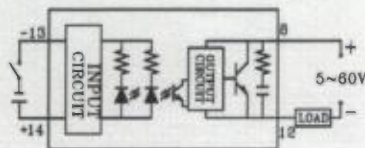

**Single phase Relay type Solid State Module**

SSR-R series

CE, RoHS

■ Specification [ Rated current corresponding to Resistive load ]

Type	型式	DC to AC type / 直流對交流型
Model	型號	SSR-R02DA
Rated current	額定電流	3A max.
I <sup>2</sup> t for fuse	熔斷電流	122A <sup>2</sup> S
Surge current	耐突波電流	120A
Peak voltage	耐突波電壓	1200VAC min.
Output voltage	輸出電壓	24 ~ 380VAC

Type	型式	DC to DC type / 直流對直流型
Model	型號	SSR-R05DD
Rated current	額定電流	5A max.
Surge current	耐突波電流	15A min.
Peak voltage	耐突波電壓	120VDC min.
Output voltage	輸出電壓	5 ~ 60 VDC

General specification / 共同規格			
Type	型式	DC to AC type	DC to DC type
Input voltage	輸入電壓	4 ~ 32 VDC	4 ~ 32 VDC
Turn off voltage	關閉電壓	< 3.0 VDC	< 3.0 VDC
Trigger current	觸發電流	12mA max.	12mA max.
Control method	控制方式	Zero cross switching	Random
Leakage current	洩漏電流	5 mA max.	1.0 mA max.
Response time	反應時間	8.3 ms (60Hz) max.	1.0 ms
Application temperature	使用溫度	Ta < 50°C	
Input immunity	輸入耐突波	2 KV (EN61000-4-4)	
Isolation strength	電介強度	4 KVrms (EN60950/VDE0805)	
Insulation strength	絕緣強度	100MΩ / 500VDC (EN60950/VDE0805)	
Circumstance	工作環境	-40°C ~ +80°C ; 35 ~ 85%RH	

■ Outline dimension / 外形尺寸

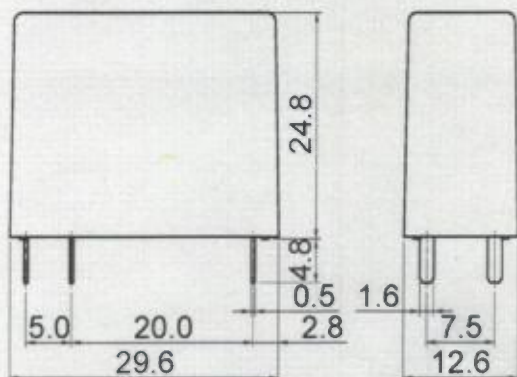

■ Connection / 接線圖

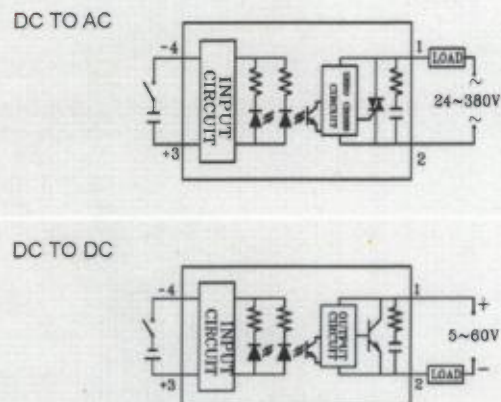

### ■ Specification [ Rated current corresponding to Resistive load ]

Type	型式	Standard type / 標準型			
Model	型號	SSR-K10DA	SSR-K20DA	SSR-K30DA	SSR-K40DA
Rated current	額定電流	10A max.	20A max.	30A max.	40A max.
I <sub>t</sub> for fuse	熔斷電流	144A <sup>2</sup> S	259A <sup>2</sup> S	664A <sup>2</sup> S	664A <sup>2</sup> S
Surge current	耐突波電流	135A	275A	410A	410A
Application temperature	使用溫度	Ta < 50°C			
Over heat protection	過熱保護	Turn off output over 120°C ; Reset below 110°C			
Peak voltage	耐突波電壓	1200VAC min.			
Output voltage	輸出電壓	24 ~ 380VAC			

Type	型式	High voltage type / 高壓型			
Model	型號	SSR-K10DA-H	SSR-K20DA-H	SSR-K30DA-H	SSR-K40DA-H
Rated current	額定電流	10A max.	20A max.	30A max.	40A max.
I <sub>t</sub> for fuse	熔斷電流	144A <sup>2</sup> S	259A <sup>2</sup> S	664A <sup>2</sup> S	664A <sup>2</sup> S
Surge current	耐突波電流	135A	275A	410A	410A
Application temperature	使用溫度	Ta < 50°C			
Over heat protection	過熱保護	Turn off output over 120°C ; Reset below 110°C			
Peak voltage	耐突波電壓	1200VAC min.			
Output voltage	輸出電壓	90~550VAC			

General specification / 共同規格		
Input voltage	輸入電壓	4 ~ 32 VDC
Turn off voltage	關閉電壓	< 3.0 VDC
Trigger current	觸發電流	12mA max.
Control method	控制方式	Zero cross
Leakage current	洩漏電流	5.0 mA max.
Response time	反應時間	8.3 ms (60Hz) max.
Input immunity	輸入耐突波	2 KV (EN61000-4-4)
Isolation strength	電介強度	4 KVrms (EN60950/VDE0805)
Insulation strength	絕緣強度	100MΩ / 500VDC (EN60950/VDE0805)
Circumstance	工作環境	-40°C ~ +80°C ; 35 ~ 85%RH

### ■ Outline dimension / 外形尺寸

10A/20A/30A

40A

### ■ Connection / 接線圖

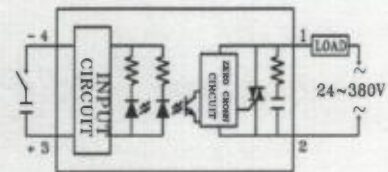

# Single phase heat sink type AC to AC Solid State Module

SSR-K series

CE, RoHS

## ■ Specification [ Rated current corresponding to Resistive load ]

Type	型式	Standard type / 標準型			
Model	型號	SSR-K10AA	SSR-K20AA	SSR-K30AA	SSR-K40AA
Rated current	額定電流	10A max.	20A max.	30A max.	40A max.
I <sup>2</sup> t for fuse	熔斷電流	144A <sup>2</sup> S	259A <sup>2</sup> S	664A <sup>2</sup> S	664A <sup>2</sup> S
Surge current	耐突波電流	135A	275A	410A	410A
Application temperature	使用溫度	Ta < 50°C			
Over heat protection	過熱保護	Turn off output over 120°C ; Reset below 110°C			
Peak voltage	耐突波電壓	1200VAC min.			
Output voltage	輸出電壓	24 ~ 380VAC			

Type	型式	High voltage type / 高壓型			
Model	型號	SSR-K10AA-H	SSR-K20AA-H	SSR-K30AA-H	SSR-K40AA-H
Rated current	額定電流	10A max.	20A max.	30A max.	40A max.
I <sup>2</sup> t for fuse	熔斷電流	144A <sup>2</sup> S	259A <sup>2</sup> S	664A <sup>2</sup> S	664A <sup>2</sup> S
Surge current	耐突波電流	135A	275A	410A	410A
Application temperature	使用溫度	Ta < 50°C			
Over heat protection	過熱保護	Turn off output over 120°C ; Reset below 110°C			
Peak voltage	耐突波電壓	1200VAC min.			
Output voltage	輸出電壓	90~550VAC			

General specification / 共同規格		
Input voltage	輸入電壓	20 ~ 265 VAC/DC
Turn off voltage	關閉電壓	< 12 VAC/DC
Trigger current	觸發電流	3VA max.
Control method	控制方式	Zero cross switching
Leakage current	洩漏電流	5 mA max.
Response time	反應時間	8.3 ms ( 60Hz )
Input immunity	輸入耐突波	2 KV ( EN61000-4-4 )
Isolation strength	電介強度	4 KVrms ( EN60950/VDE0805 )
Insulation strength	絕緣強度	100MΩ / 500VDC ( EN60950/VDE0805 )
Circumstance	工作環境	-40°C ~ +80°C ; 35 ~ 85%RH

## ■ Outline dimension / 外形尺寸



## ■ Connection / 接線圖

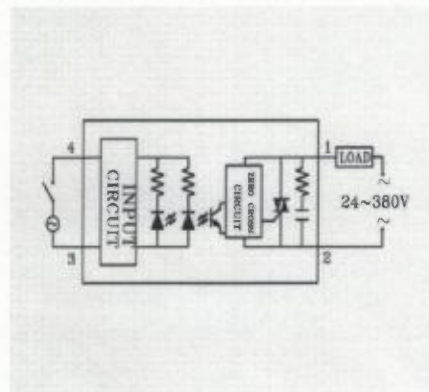

### ■ Specification [ Rated current corresponding to Resistive load ]

Type	型式	Standard type / 標準型			
Model	型號	SCR-K10LA	SCR-K20LA	SCR-K30LA	SCR-K40LA
Rated current	額定電流	10A max.	20A max.	30A max.	40A max.
I <sup>2</sup> t for fuse	熔斷電流	144A <sup>2</sup> S	259A <sup>2</sup> S	664A <sup>2</sup> S	664A <sup>2</sup> S
Surge current	耐突波電流	135A	275A	410A	410A
Application temperature	使用溫度	Ta < 50°C			
Over heat protection	過熱保護	Turn off output over 120°C ; Reset below 110°C			
Peak voltage	耐突波電壓	1200VAC min.			
Output voltage	輸出電壓	90 ~ 380VAC			

Type	型式	High voltage type / 高壓型			
Model	型號	SCR-K10LA-H	SCR-K20LA-H	SCR-K30LA-H	SCR-K40LA-H
Rated current	額定電流	10A max.	20A max.	30A max.	40A max.
I <sup>2</sup> t for fuse	熔斷電流	144A <sup>2</sup> S	259A <sup>2</sup> S	664A <sup>2</sup> S	664A <sup>2</sup> S
Surge current	耐突波電流	135A	275A	410A	410A
Application temperature	使用溫度	Ta < 50°C			
Over heat protection	過熱保護	Turn off output over 120°C ; Reset below 110°C			
Peak voltage	耐突波電壓	1200VAC min.			
Output voltage	輸出電壓	180 ~ 550VAC			

General specification / 共同規格		
Input method	輸入方式	4 ~ 20 mA
Input resistance	輸入阻抗	Approx. 1.2KΩ
Control method	控制方式	Phase control
Leakage current	洩漏電流	0.5% of full load max.
Response time	反應時間	1.0ms max.
Input immunity	輸入耐突波	2 KV ( EN61000-4-4 )
Isolation strength	電介強度	4 KVrms ( EN60950/VDE0805 )
Insulation strength	絕緣強度	100MΩ / 500VDC ( EN60950/VDE0805 )
Circumstance	工作環境	-40°C ~ +80°C ; 35 ~ 85%RH

### ■ Outline dimension / 外形尺寸



### ■ Connection / 接線圖

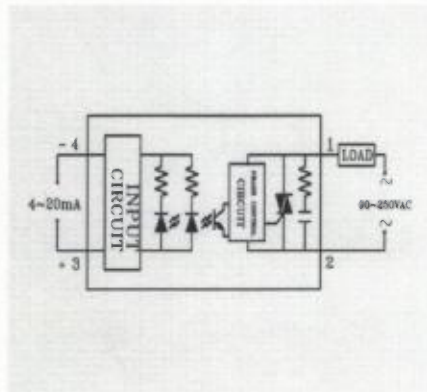

# Single phase heat sink type DC to DC Solid State Module

SSR-K series

CE, RoHS

## ■ Specification [ Rated current corresponding to Resistive load ]

Type	型式	Standard type / 標準型	High voltage type / 高壓型
Model	型號	SSR-K25DD	SSR-K10DD-H
Rated current	額定電流	25 A max.	10A max.
Application temperature	使用溫度	Ta < 50°C	Ta < 50°C
Surge current	耐突波電流	120A	60A min.
Peak voltage	耐突波電壓	120VDC min.	300VDC min.
Output voltage	輸出電壓	5 ~ 60VDC	5 ~ 150VDC

Type	型式	Linear control type / 線性控制型
Model	型號	SSR-K10LD
Rated current	額定電流	10A max.
Application temperature	使用溫度	Ta < 50°C
Surge current	耐突波電流	60A min.
Peak voltage	耐突波電壓	120VDC min.
Output voltage	輸出電壓	5 ~ 60VDC

General specification / 共同規格			
Type	型式	DC to DC	Linear control DC to DC
Input method	輸入方式	4 ~ 32 VDC	4 ~ 20mA
Turn off voltage	關閉電壓	< 3.0 VDC	non
Input current	輸入電流	12mA max.	non
Control method	控制方式	Random	PWM
Leakage current	洩漏電流	1.0 mA max.	1.0 mA max.
Response time	反應時間	1.0 ms	1.0ms
Application temperature	使用溫度	Ta < 50°C	
Input immunity	輸入耐突波	2 KV ( EN61000-4-4 )	
Isolation strength	電介強度	4 KVrms ( EN60950/VDE0805 )	
Insulation strength	絕緣強度	100MΩ / 500VDC ( EN60950/VDE0805 )	
Circumstance	工作環境	-40°C ~ +80°C : 35 ~ 85%RH	

## ■ Outline dimension / 外形尺寸

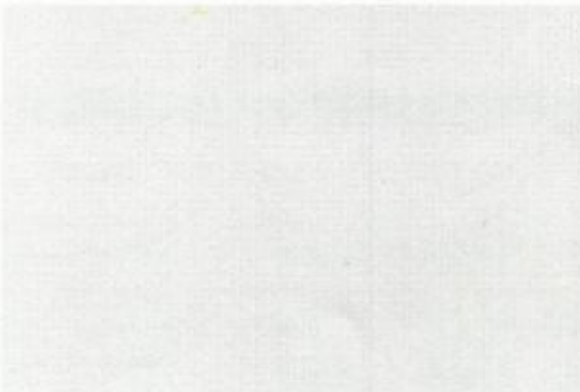

## ■ Connection / 接線圖

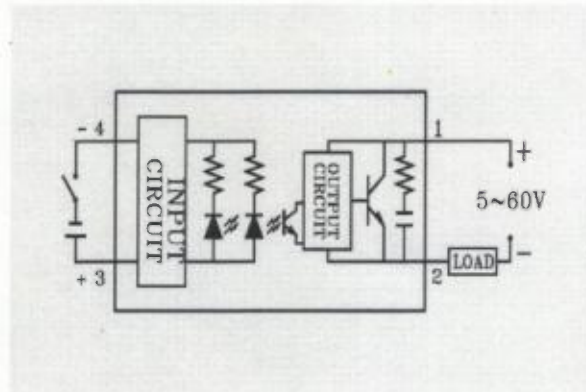

## ■ Specification [ Rated current corresponding to Resistive load ]

Type	型式	Standard type / 標準型			
Model	型號	TSR-25DA	TSR-40DA	TSR-60DA	TSR-75DA
Rated current	額定電流	25A max.	40A max.	50A max.	75A max.
I <sup>2</sup> t for fuse	熔斷電流	259A <sup>2</sup> s	664A <sup>2</sup> s	518A <sup>2</sup> S	1328A <sup>2</sup> S
Surge current	耐突波電流	275A	410A	550A	820A
Peak voltage	耐突波電壓	1200VAC			
Output voltage	輸出電壓	24 ~ 380VAC			

Type	型式	High voltage type / 高壓型			
Model	型號	TSR-25DA-H	TSR-40DA-H	TSR-60DA-H	TSR-75DA-H
Rated current	額定電流	25A max.	40A max.	50A max.	75A max.
I <sup>2</sup> t for fuse	熔斷電流	259A <sup>2</sup> s	664A <sup>2</sup> s	50A max.	75A max.
Surge current	耐突波電流	275A	410A	518A <sup>2</sup> S	1328A <sup>2</sup> S
Peak voltage	耐突波電壓	1200VAC			
Output voltage	輸出電壓	90 ~ 480VAC			

		General specification / 共同規格	
Input voltage	輸入電壓	4 ~ 32 VDC	
Turn off voltage	關閉電壓	< 3.0 VDC	
Trigger current	觸發電流	30mA max.	
Control method	控制方式	Zero cross switching	
Leakage current	洩漏電流	5 mA max.	
Response time	反應時間	8.3 ms ( 60Hz )	
Input immunity	輸入耐突波	2 KV ( EN61000-4-4 )	
Isolation strength	電介強度	4 KVrms ( EN60950/VDE0805 )	
Insulation strength	絕緣強度	100MΩ / 500VDC ( EN60950/VDE0805 )	
Circumstance	工作環境	-40°C ~ +80°C ; 35 ~ 85%RH	

## ■ Outline dimension / 外形尺寸    ■ Connection / 接線圖



# Three phase AC to AC Solid State Module

TSR series

CE, RoHS

## ■ Specification [ Rated current corresponding to Resistive load ]

Type	型式	Standard type / 標準型			
Model	型號	TSR-25AA	TSR-40AA	TSR-50AA	TSR-75AA
Rated current	額定電流	25A max.	40A max.	50A max.	75A max.
I <sup>2</sup> t for fuse	熔斷電流	259A <sup>2</sup> s	664A <sup>2</sup> s	518A <sup>2</sup> S	1328A <sup>2</sup> S
Surge current	耐突波電流	275A	410A	550A	820A
Peak voltage	耐突波電壓	1200VAC			
Output voltage	輸出電壓	24 ~ 380VAC			

Type	型式	High voltage type / 高壓型			
Model	型號	TSR-25AA-H	TSR-40AA-H	TSR-50AA-H	TSR-75AA-H
Rated current	額定電流	25A max.	40A max.	50A max.	75A max.
I <sup>2</sup> t for fuse	熔斷電流	259A <sup>2</sup> s	664A <sup>2</sup> s	518A <sup>2</sup> S	1328A <sup>2</sup> S
Surge current	耐突波電流	275A	410A	550A	820A
Peak voltage	耐突波電壓	1200VAC			
Output voltage	輸出電壓	90 ~ 480VAC			

General specification / 共同規格		
Input voltage	輸入電壓	80 ~ 250 VAC 50/60Hz
Turn off voltage	關閉電壓	< 35 VAC
Trigger current	觸發電流	2.0VA max.
Control method	控制方式	Zero cross switching
Leakage current	洩漏電流	5 mA max.
Response time	反應時間	8.3 ms ( 60Hz )
Input immunity	輸入耐突波	2 KV ( EN61000-4-4 )
Isolation strength	電介強度	4 KVrms ( EN60950/VDE0805 )
Insulation strength	絕緣強度	1000MΩ / 500VDC ( EN60950/VDE0805 )
Circumstance	工作環境	-40°C ~ +80°C ; 35 ~ 85%RH

## ■ Outline dimension / 外形尺寸

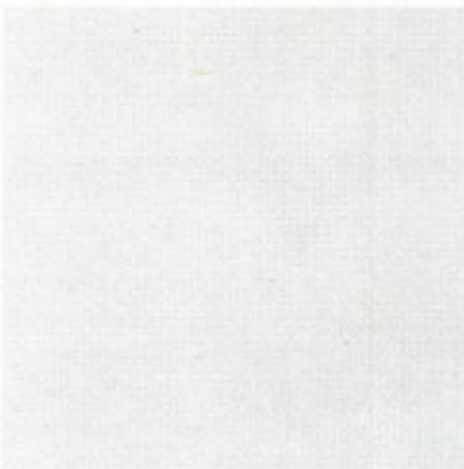

## ■ Connection / 接線圖



### ■ Specification [ Rated current corresponding to Resistive load ]

Type	型式	Standard type / 標準型				
Model	型號	ESR-25DA	ESR-40DA	ESR-60DA	ESR-80DA	ESR-100DA
Rated current	額定電流	25A max	40A max.	60A max.	80A max.	100A max.
I <sup>2</sup> t for fuse	熔斷電流	259A <sup>2</sup> s	664A <sup>2</sup> s	1800A <sup>2</sup> s	3200A <sup>2</sup> s	7200A <sup>2</sup> s
Surge current	耐突波電流	275A	410A	850A	1200A	1750A
Peak voltage	耐突波電壓	1200VAC	1200VAC	1200VAC	1200VAC	1200VAC
Output voltage	輸出電壓	24 ~ 380VAC				

Type	型式	High voltage type / 高壓型				
Model	型號	ESR-25DA-H	ESR-40DA-H	ESR-60DA-H	ESR-80DA-H	ESR-100DA-H
Rated current	額定電流	25A max	40A max.	60A max.	80A max.	100A max.
I <sup>2</sup> t for fuse	熔斷電流	259A <sup>2</sup> s	664A <sup>2</sup> s	1800A <sup>2</sup> s	3200A <sup>2</sup> s	7200A <sup>2</sup> s
Surge current	耐突波電流	275A	410A	850A	1200A	1750A
Peak voltage	耐突波電壓	1200VAC	1200VAC	1200VAC	1200VAC	1200VAC
Output voltage	輸出電壓	90 ~ 480VAC				

General specification / 共同規格		
Input voltage	輸入電壓	4 ~ 32 VDC
Turn off voltage	關閉電壓	< 3.0 VDC
Trigger current	觸發電流	30mA max
Control method	控制方式	Zero cross switching
Leakage current	洩漏電流	5 mA max.
Response time	反應時間	8.3 ms (60Hz)
Over heat protection	過熱保護	Turn off output over 120°C ; Reset below 110°C
Input immunity	輸入耐突波	2 KV ( EN61000-4-4 )
Isolation strength	電介強度	4 KVrms ( EN60950/VDE0805 )
Insulation strength	絕緣強度	100MΩ / 500VDC ( EN60950/VDE0805 )
Circumstance	工作環境	-40°C ~ +80°C ; 35 ~ 85%RH

### ■ Outline dimension / 外形尺寸

ESR-xxDA / ESR-xxDA-H

ESR-□□□+  
Heat sink ( HS-ESR-100 ) + Fan

### ■ Connection / 接線圖

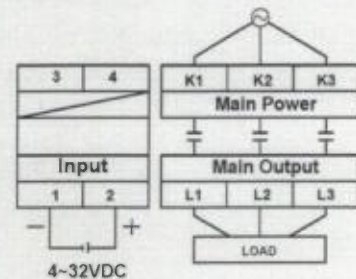

# High Power Three Phase AC to AC Solid State Module

ESR series

CE, RoHS

## ■ Specification [ Rated current corresponding to Resistive load ]

Type	型式	Standard type / 標準型				
Model	型號	ESR-25AA	ESR-40AA	ESR-60AA	ESR-80AA	ESR-100AA
Rated current	額定電流	25A max	40A max.	60A max.	80A max.	100A max.
I <sup>2</sup> t for fuse	熔斷電流	259A <sup>2</sup> s	664A <sup>2</sup> s	1800A <sup>2</sup> s	3200A <sup>2</sup> s	7200A <sup>2</sup> s
Surge current	耐突波電流	275A	410A	850A	1200A	1750A
Peak voltage	耐突波電壓	1200VAC	1200VAC	1200VAC	1200VAC	1200VAC
Output voltage	輸出電壓	24 ~ 380VAC				

Type	型式	High voltage type / 高壓型				
Model	型號	ESR-25AA-H	ESR-40AA-H	ESR-60AA-H	ESR-80AA-H	ESR-100AA-H
Rated current	額定電流	25A max	40A max.	60A max.	80A max.	100A max.
I <sup>2</sup> t for fuse	熔斷電流	259A <sup>2</sup> s	664A <sup>2</sup> s	1800A <sup>2</sup> s	3200A <sup>2</sup> s	7200A <sup>2</sup> s
Surge current	耐突波電流	275A	410A	850A	1200A	1750A
Peak voltage	耐突波電壓	1200VAC	1200VAC	1200VAC	1200VAC	1200VAC
Output voltage	輸出電壓	90 ~ 480VAC				

General specification / 共同規格		
Input voltage	輸入電壓	20 ~ 265 VAC/DC
Turn off voltage	關閉電壓	< 10 VAC/DC
Trigger current	觸發電流	3VA max.
Control method	控制方式	Zero cross switching
Leakage current	洩漏電流	5 mA max.
Response time	反應時間	8.3 ms ( 60Hz )
Over heat protection	過熱保護	Turn off output over 120°C : Reset below 110°C
Input immunity	輸入耐突波	2 KV ( EN61000-4-4 )
Isolation strength	電介強度	4 KVrms ( EN60950/VDE0805 )
Insulation strength	絕緣強度	100MΩ / 500VDC ( EN60950/VDE0805 )
Circumstance	工作環境	-40°C ~ +80°C : 35 ~ 85%RH

## ■ Outline dimension / 外形尺寸

ESR-xxDA / ESR-xxDA-H

ESR-□□□+  
Heat sink ( HS-ESR-100 ) + Fan

## ■ Connection / 接線圖

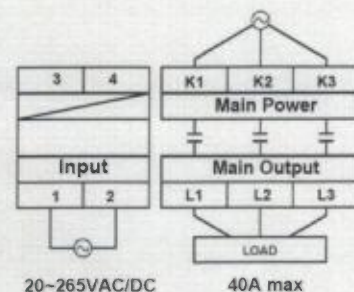

### ■ Specification [ Rated current corresponding to Resistive load ]

Type	型式	Standard fuse type / 標準保險絲型			
Model	型號	ESR-40DA+	ESR-60DA+	ESR-80DA+	ESR-100DA+
Rated current	額定電流	40A max.	60A max.	80A max.	100A max.
I <sup>2</sup> t for fuse	熔斷電流	664A <sup>2</sup> s	1800A <sup>2</sup> s	3200A <sup>2</sup> s	7200A <sup>2</sup> s
Protection fuse	保險絲	40A/600VAC	63A/600VAC	80A/600VAC	100A/600VAC
Surge current	耐突波電流	410A	850A	1200A	1750A
Peak voltage	耐突波電壓	1200VAC	1200VAC	1200VAC	1200VAC
Output voltage	輸出電壓	24 ~ 380VAC			

Type	型式	High voltage fuse type / 高壓保險絲型			
Model	型號	ESR-40DA-H+	ESR-60DA-H+	ESR-80DA-H+	ESR-100DA-H+
Rated current	額定電流	40A max.	60A max.	80A max.	100A max.
I <sup>2</sup> t for fuse	熔斷電流	664A <sup>2</sup> s	1800A <sup>2</sup> s	3200A <sup>2</sup> s	7200A <sup>2</sup> s
Protection fuse	保險絲	40A/600VAC	63A/600VAC	80A/600VAC	100A/600VAC
Surge current	耐突波電流	650A	850A	1200A	1750A
Peak voltage	耐突波電壓	1200VAC	1200VAC	1200VAC	1200VAC
Output voltage	輸出電壓	90 ~ 480VAC			

General specification / 共同規格		
Input voltage	輸入電壓	4 ~ 32 VDC
Turn off voltage	關閉電壓	< 3.0 VDC
Trigger current	觸發電流	30mA max.
Control method	控制方式	Zero cross switching
Leakage current	洩漏電流	5 mA max.
Response time	反應時間	8.3 ms ( 60Hz )
Over heat protection	過熱保護	Turn off output over 120°C : Reset below 110°C
Input immunity	輸入耐突波	2 KV ( EN61000-4-4 )
Isolation strength	電介強度	4 KVrms ( EN60950/VDE0805 )
Insulation strength	絕緣強度	1000MΩ / 500VDC ( EN60950/VDE0805 )
Circumstance	工作環境	-40°C ~ +80°C : 35 ~ 85%RH

### ■ Outline dimension / 外形尺寸

ESR-xxDA+ / ESR-xxDA-H+

### ■ Connection / 接線圖

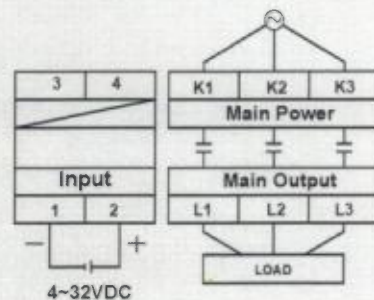

## ■ Specification [ Rated current corresponding to Resistive load ]

Type	型式	Standard fuse type / 標準保險絲型			
Model	型號	ESR-40AA+	ESR-60AA+	ESR-80AA+	ESR-100AA+
Rated current	額定電流	40A max.	60A max.	80A max.	100A max.
I <sup>2</sup> t for fuse	熔斷電流	664A <sup>2</sup> s	1800A <sup>2</sup> s	3200A <sup>2</sup> s	7200A <sup>2</sup> s
Protection fuse	保險絲	40A/600VAC	63A/600VAC	80A/600VAC	100A/600VAC
Surge current	耐突波電流	410A	850A	1200A	1750A
Peak voltage	耐突波電壓	1200VAC	1200VAC	1200VAC	1200VAC
Output voltage	輸出電壓	24 ~ 380VAC			

Type	型式	High voltage fuse type / 高壓保險絲型			
Model	型號	ESR-40AA-H+	ESR-60AA-H+	ESR-80AA-H+	ESR-100AA-H+
Rated current	額定電流	40A max.	60A max.	80A max.	100A max.
I <sup>2</sup> t for fuse	熔斷電流	664A <sup>2</sup> s	1800A <sup>2</sup> s	3200A <sup>2</sup> s	7200A <sup>2</sup> s
Protection fuse	保險絲	40A/600VAC	63A/600VAC	80A/600VAC	100A/600VAC
Surge current	耐突波電流	650A	850A	1200A	1750A
Peak voltage	耐突波電壓	1200VAC	1200VAC	1200VAC	1200VAC
Output voltage	輸出電壓	90 ~ 480VAC			

General specification / 共同規格		
Input voltage	輸入電壓	20 ~ 265 VAC/DC
Turn off voltage	關閉電壓	< 10 VAC/DC
Trigger current	觸發電流	3VA max.
Control method	控制方式	Zero cross switching
Leakage current	洩漏電流	5 mA max.
Response time	反應時間	8.3 ms ( 60Hz )
Over heat protection	過熱保護	Turn off output over 120°C ; Reset below 110°C
Input immunity	輸入耐突波	2 KV ( EN61000-4-4 )
Isolation strength	電介強度	4 KVrms ( EN60950/VDE0805 )
Insulation strength	絕緣強度	100MΩ / 500VDC ( EN60950/VDE0805 )
Circumstance	工作環境	-40°C ~ +80°C ; 35 ~ 85%RH

## ■ Outline dimension / 外形尺寸

ESR-xxAA+ / ESR-xxAA-H+

## ■ Connection / 接線圖

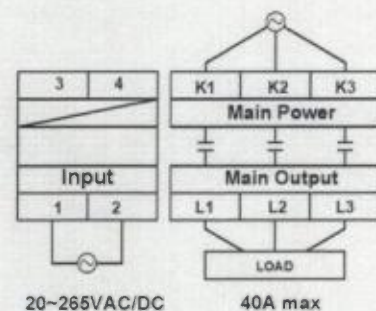

### ■ Specification [ Rated current corresponding to Resistive load ]

Type	型式	DC to AC type / 直流對交流型		DC to DC type / 直流對直流型	
Model	型號	SSR-P03DA	SSR-M01DA	SSR-P03DD	SSR-M06DD
Rated current	額定電流	3A max.	1A max.	3A max.	5A max.
I <sub>t</sub> for fuse	熔斷電流	122A <sup>2</sup> S	15A <sup>2</sup> S		
Surge current	耐突波電流	120A min.	15A min.	12A min.	
Peak voltage	耐突波電壓	1200VAC min.		120VDC min.	
Output voltage	輸出電壓	24 ~ 380VAC		5 ~ 60 VDC	

### General specification / 共同規格

Type	型式	DC to AC type / 直流對交流型	DC to DC type / 直流對直流型
Input voltage	輸入電壓	4 ~ 32 VDC	4 ~ 32 VDC
Turn off voltage	關閉電壓	< 3.0 VDC	< 3.0 VDC
Trigger current	觸發電流	12mA max.	12mA max.
Control method	控制方式	Zero cross switching	Random
Leakage current	洩漏電流	5 mA max.	1.0 mA
Response time	反應時間	8.3 ms (60Hz) max.	1.0 ms
Input immunity	輸入耐突波	2 KV ( EN61000-4-4 )	
Isolation strength	電介強度	4 KVrms ( EN60950/VDE0805 )	
Insulation strength	絕緣強度	100MΩ / 500VDC ( EN60950/VDE0805 )	
Circumstance	工作環境	-40°C ~ +80°C : 35 ~ 85%RH	

### ■ Outline dimension / 外形尺寸



### ■ Connection / 接線圖

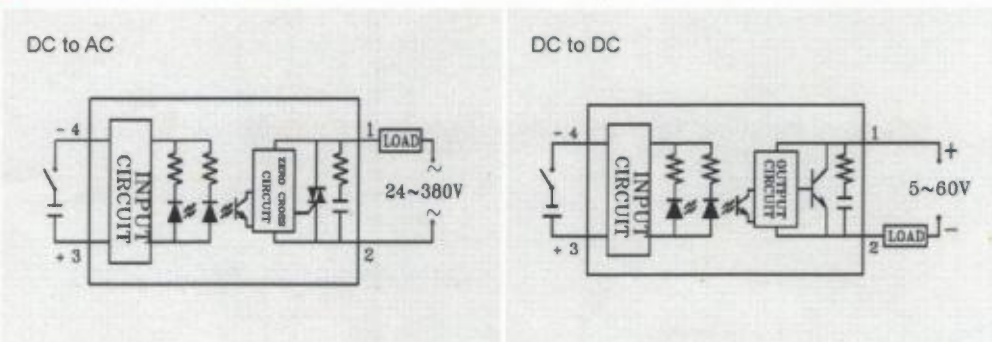

## How to use Heat sink & Cooling Fan for HPR series / 如何使用散熱器及冷卻風扇

Line current (Average current / 平均電流)	Heat sink	Cooling fan	Heat sink (HS-50H)
$I_L < 5$ Amps	Non-required	Non-required	
$I_L < 12$ Amps	HS-50H	Non-required	
$I_L < 25$ Amps	HS-ESR-60	Non-required	
$I_L < 25$ Amps	HS-ESR-60	Required	

## Notice of use / 使用注意事項

- To protect the solid state module against a short-circuit of the load, please use a fuse with a  $I^2t$  value  $< 1/2 I^2t$  value specified.  
請加裝快速保險絲 ( $I^2t$  value 小於額定值的一半)，以防止因負載短路而造成固態模組燒毀。
- The thermal conductive silicone rubber or thermal grease is required  
When the solid state module is mounted on a heat sink  
本固態模組加裝散熱器時務必墊高導熱系數的矽膠片或散熱膏【導熱系數 (K)  $> 4.5$ 】。
- The rated current is corresponding to a resistive load, if the solid state module is applied in other loads, Please consider the inrush current at turn on and the surge voltage at turn off.  
本固態模組所標示的額定電流是以電阻性負載為準，如果使用在其他負載上須考慮起動電流及關機突波。
  - Electric discharge lamps: Those loads have the 「inrush current」 at turn on and the 「surge voltage」 at turn off, please use 「high voltage type」 on 220VAC mains.  
電子起動式燈具（如日光燈）：須考慮起動電流及關機突波，220VAC電源系統請選用「高壓型」。
  - Incandescent lamp: The rated current of the module must be over 4 times of the incandescent lamp current.  
炙熱燈泡（如IR燈管）：須考慮起動電流，固態模組的額定電流須大於炙熱燈泡電流的「四倍」。
  - Three phase motors: The rated current of the s module must be over 4 times of the three phase motor average current.  
三相馬達：須考慮起動電流，固態模組的額定電流須大於三相馬達平均電流的「四倍」。
  - Transformer loads: The rated current of the module must be over 10 times of the transformer current.  
變壓器負載：須考慮反電動電流，固態模組的額定電流須大於變壓負載電流的「十倍」。
  - Capacitor loads, the rated current of the module must be over 3 times of the capacitor current.  
電容性負載：須考慮充電瞬間電流，固態模組的額定電流須大於電容性負載電流的「三倍」。

## Notice of safety / 安全注意事項

**Warning** Potentially hazardous situation, if mishandling, may result in death or serious injury.  
潛在危險，如果操作失當可能導致死亡或嚴重傷害。

- Please do not touch any terminal of this module while power supply is supplied, if do, it may result in electronic shock.  
送電中，請勿碰觸本固態模組任何接線端子以避免觸電。
- 「Power supply system」 must to be shutdown before renew the fuse, if not, it may result in electronic shock.  
更換保險絲前，請務必關閉電源系統以避免觸電。
- Please rated the load current within the specified value, if not, it may result to burn up this module or fuse.  
負載電流請勿超過額定電流，以避免保險絲或本固態模組燒毀。
- Please tighten the screw terminal over 100kg-cm, if not, it may result to burn up this module or fuse.  
請務必鎖緊端子螺絲，扭力須超過100kg-cm，否則可能導致本固態模組或保險絲燒毀。
- If this module is burned up, it may be in short circuit condition or malfunction, Please settle an independent alarm system to ensure safety protection, if not, it may result in a serious accident.  
本固態模組燒毀後可能是短路或失控狀態，請加裝獨立警報系統以確保安全，否則可能造成嚴重意外事故。

**H type**

**H type Rail bracket ( HS-BR-1 )**

Model	Length(L mm)	Current duration	PCS for SSR
HS-50H	50.0	10A max.	Single
HS-100H	100.0	20A max.	Twice
HS-150H	150.0	30A max.	Three
HS-200H	200.0	---	Four

**Standard type**

Model	Length(L mm)	Current duration	PCS for SSR
HS-50	50.0	15A max.	Single
HS-100	100.0	30A max.	Twice
HS-150	150.0	50A max.	Three
HS-200	200.0	---	Four
HS-250	250.0	---	Five

**How to use Heat sink & Cooling Fan for ESR series / 如何使用散熱器及冷卻風扇**

Line current ( Average current / 平均電流 )	Heat sink	Cooling fan	Calculating of Line current 線電流計算
$I_L < 5$ Amps	Non-required	Non-required	$I_L = W \div (\sqrt{3} \times V_L \times \cos\theta)$ $I_L = W \div (\sqrt{3} \times V_L \times \cos\theta)$ VL: Line voltage; cosθ: Power factor
$I_L < 10$ Amps	HS-ESR-100	Non-required	
$I_L > 10$ Amps	HS-ESR-100	Required	

\* Model of Heat sink: HS-ESR-100 \* Outline of cooling fan: 80mm x 80mm

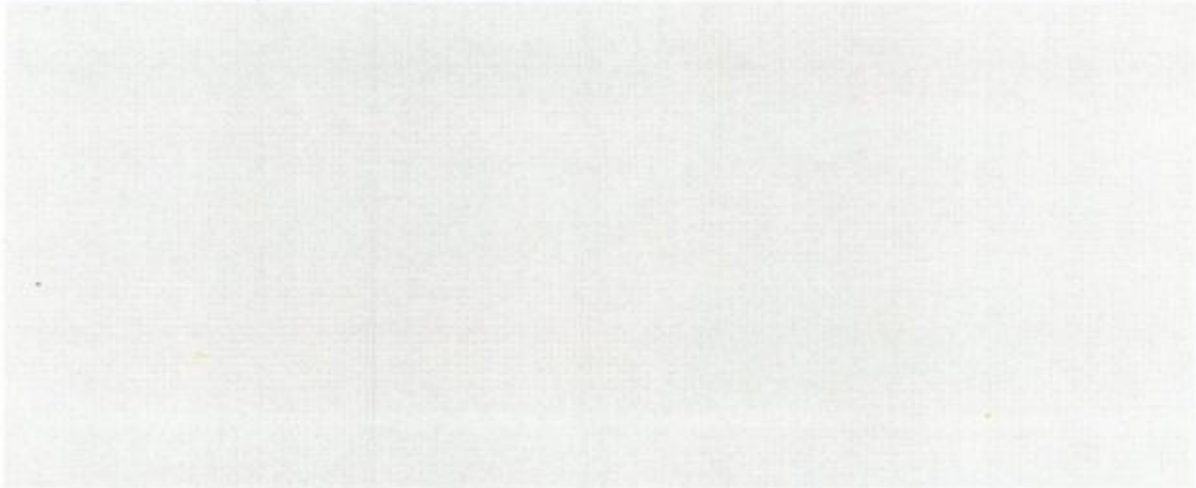

■ Model

Model	Description	Model	Description
SSR-P03N-2P	2 units / NPN input	SSR-P03P-2P	2 units / PNP input
SSR-P03N-4P	4 units / NPN input	SSR-P03P-4P	4 units / PNP input
SSR-P03N-8P	8 units / NPN input	SSR-P03P-8P	8 units / PNP input

■ Outline dimension / 外形尺寸

Type	L
SSR-P03-1P	20.0
SSR-P03-2P	33.6
SSR-P03-4P	29.6
SSR-P03-8P	111.6

■ Connection / 接線圖

SSR-P03□-2P

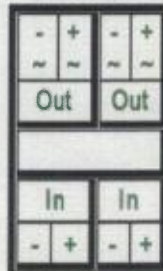

SSR-P03□-4P

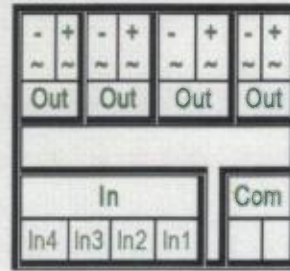

SSR-P03□-8P

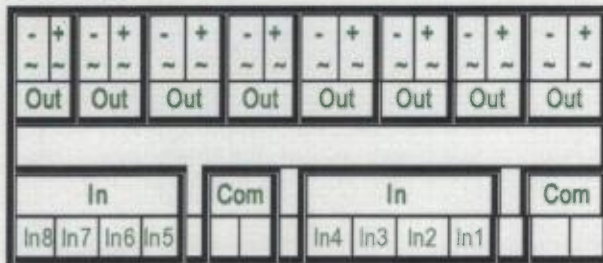



Think Controls

**FOTEK**

Specification may be modified without notice in advance (2012/10/12)

陽明電機股份有限公司  
**FOTEK CONTROLS CO., LTD.**